



SUPPLY NETWORK ANALYZERS

**CVM-BD-420-4 & CVM-BD-420-8
SERIES**

INSTRUCTION MANUAL

(M 981 323 / 01A)

(c) CIRCUTOR S.A.

CVM-BD-420-4 & CVM-BD-420-8 SUPPLY NETWORK ANALYZERS

	Page
1.- BASIC INSTRUCTIONS	2
1.1.- Delivery spot check	2
1.2.- Connection procedures	2
1.3.- CVM-BD-420 types	3
2.- MAIN CHARACTERISTICS	3
2.1.- Other characteristics	6
3.- INSTALLATION AND STARTUP	6
3.1.- Installation	7
3.2.- CVM-BD-420-.. connection terminal	9
3.3.- Connection drawing for the CVM-BD-420-..	10
4.- OPERATION MODE	14
5.- SETUP	16
5.1.- Phase-to-Phase or Phase-to-Neutral voltages	16
5.2.- Voltage Transformer Primary	17
5.3.- Voltage Transformer Secondary	18
5.4.- Current Transformer Primary.....	18
5.5.- Parameter SETUP.....	19
5.6.- First Page SETUP.....	22
5.7.- Maximum power demand	23
5.8.- TIME / DATE SETUP.....	24
5.9.- Clearing Energy Counters	25
5.10.- 4 - 20 mA Type outputs.....	26
6.- SPECIFICATIONS.....	29
7.- SAFETY CONSIDERATIONS	30
8.- MAINTENANCE	31
9.- TECHNICAL SERVICE	31

1.- BASIC INSTRUCTIONS

1.1.- Delivery spot check

This manual is issued to help all the CVM-BD-420-4 & CVM-BD-420-8 users to install and use it in order to get the best from it. After receiving the unit please check the following points:

- (a) Does this device corresponds to your order specifications?
- (b) Check if any damage was done during the shipment process.
- (c) Verify that it includes *One instruction manual .

1.2.- Connection procedures

Before connecting the instrument to the mains verify the following:

(a) Power supply :

- 230 V a.c.** Power supply Va.c. (Single phase)
- Frequency: 50 ... 60 Hz

(b) Maximum measuring voltage:

- Standard : 500 V a.c. phase-neutral / 866 V a.c. between phases
- A special model for 110 V measuring is available:*
100 V a.c. phase-neutral / 173 V a.c. between phases

(c) Maximum measuring current: Transformer of In / 5 A a.c.

1.3.- CVM-BD-420 types

Two CVM-BD-420 types are available according to the number of analog outputs that the analyzer equips:

Code	Type	Features
7 70 262	CVM-BD-420-4	4C + 4 analog outputs + display
7 70 263	CVM-BD-420-8	4C + 8 analog outputs + display

2.- MAIN CHARACTERISTICS

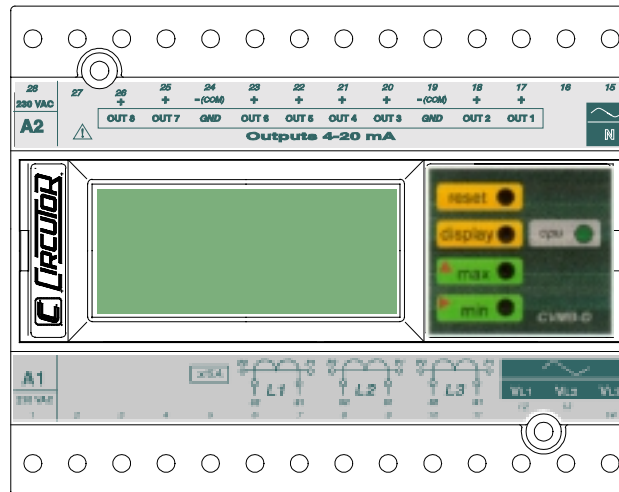

The CVM-BD-420-4 & CVM-BD-420-8 power meters are programmable measuring instruments, offering several operation possibilities selectable in their SETUP option. Before power supplying the instrument, read the **CONNECTIONS** and **SETUP** sections and choose the most suitable operation mode for getting your desired data.

4 or 8 user-programmable analog outputs are available. (Section 5.10)

The CVM-BD-420-.. is an instrument which measures, calculates and displays all the main electrical parameters at any electrical network (balanced or not). The measuring is true RMS value, through three a.c. Voltage inputs and three a.c. Current inputs (from Current Transformers .../ 5A).

By means of an internal microprocessor it simultaneously measures:

<i>Parameter</i>	<i>L1</i>	<i>L2</i>	<i>L3</i>	<i>Average</i>	<i>Addition</i>
Voltage (phase-neutral)	x	x	x	x	
Voltage (phase-phase)	x	x	x	x	
Current	x	x	x	x	
Active power	x	x	x		X
Reactive power L	x	x	x		X
Reactive power C	x	x	x		X
Power factor	x	x	x	x	
Apparent power					X
Frequency	x				

<i>Parameter</i>	<i>CVM-BD-420-..</i>
Date/Time dd/mm/yy hh:mm:ss	TIME
Active energy (two indep. meters: demanded energy (+) and generated energy (--))	kWh (+) and (--)
Reactive energy (inductive), two indep. meters	kvarh.L (+) and (--)
Reactive energy (capacitive), two indep. meters	kvarh.C (+) and (--)

The CVM-BD-420-.. allows reading up to 54 electrical parameters in 18 screens, shown in a three line numerical display, where you can see:

- (a) Phase-phase or phase-neutral voltage of the three phases
- (b) 51 user-selectable parameters according to the model (see attached table)



And also the **MAXIMUM POWER DEMAND**: The power demand is integrated during a prefixed period.

You can select:

- a) The parameter to be controlled (it can measure active power **kW**, apparent power **kVA** or three phase average current **AIII**).
- b) The demand period (1 to 60 min.).

This power demand function works with sliding window : shows the accumulated demand over the last period from "now".

☞ The CVM-BD-420-.. is a 4 quadrant analyzer, that is, this can automatically detect the energy sign:

Example of the phase difference between voltage and current	Active power kW or kW.h	Reactive power kvar or kvar.h	P.F.
30°	kW +	kvar L +	+
300°	kW +	kvar C +	--
210°	kW --	kvar L --	+
120°	kW --	kvar C --	--

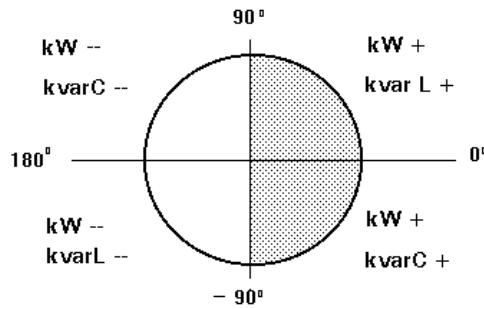

2.1- Other Characteristics

- DIN rail mounting device with low dimensions.
- True RMS value measurements.
- 4 or 8 user-programmable analog inputs.
- Measurements in all four quadrants (equivalent to CVMk-4C).
- Power demand control.
- Memorizes Maximum and Minimum values.
- Two leds for indication of CPU and communication operation
- Incorporates the calculation of the harmonic distortion.



3.- INSTALLATION AND STARTUP

The manual you hold in your hands contains information and warnings that the user should respect in order to guarantee a proper operation of all the instrument functions and keep its safety conditions.

The instrument must not be powered and used until its definitive assembly on the cabinet's door.

Whether the instrument is not used as manufacturer's specifications, the protection of the instrument can be damaged.

When any protection failure is suspected to exist (for example, it presents external visible damages), the instrument must be immediately powered off. In this case contact a qualified service representative.

3.1.- INSTALLATION

Before applying AC power to the, check following points :

a.- **Supply voltage :**

- Power supply V a.c. (Single phase) 50 ...60 Hz

230 V a.c.

- *Frequency* : 50 ... 60 Hz
- *Supply tolerance* : + 10 % / --15 %
- *Connection terminals* : Terminals 1 - 28
- *Instrument burden* : 6 VA

b.- Maximum voltage at the voltage measuring circuit:

Standard : 500 V a.c. phase-neutral / 866 V a.c. between phases

A special model CVM-BD-420-4 & CVM-BD-420-8 for 110 V measurement is also available:

100 V a.c. phase-neutral / 173 V a.c. between phases

c.- Maximum admissible current : Transformer of In / 5 A a.c.

d.- Operation conditions :

- Operating temperature : 0 to 50°C
- Humidity : 25 to 80 % R.H. non-condensing

e.- Safety : Designed to meet protection class II as per EN 61010.

Mounting: 

Instrument is to be mounted on DIN rail mounting device with low dimensions.
All connections keep inside the cabinet.

Note that with the instrument powered on, the terminals could be dangerous to touching and cover opening actions or elements removal may allow accessing dangerous parts. Therefore, the instrument must not be used until this is completely installed.

The instrument must be connected to a power supply circuit protected with gl type (IEC 269) or M type fuses rated between 0.5 and 2 A. This circuit should be provided with an automatic switch or any equivalent element to disconnect the instrument from the power supply network. The supply and measuring voltage circuits will be both connected through a wire with a minimum cross-section of 1 mm². The line of the current transformer secondary will have a minimum cross-section of 2,5 mm².

3.2.- CVM-BD-420-.. Connection terminal

Terminal No	Designation	Concept
1 - 28	A1 - A2	supply voltage : 230 V a.c.
17	Out 1	4-20 mA type output 1
18	Out 2	4-20 mA type output 2
19	GND	Ground
20	Out 3	4-20 mA type output 3
21	Out 4	4-20 mA type output 4
22	Out 5	4-20 mA type output 5
23	Out 6	4-20 mA type output 6
24	GND	Ground
25	Out 7	4-20 mA type output 7
26	Out 8	4-20 mA type output 8
15	N	NEUTRAL
14	VL3	Voltage phase 3
13	VL2	Voltage phase 2
12	VL1	Voltage phase 1
11 - 10	I L3: s1 - s2	Current phase L3 .../ 5 A
9 - 8	I L2: s1 - s2	Current phase L2 .../ 5 A
7 - 6	I L1: s1 - s2	Current phase L1 .../ 5 A

NOTE: Current inputs are isolated

3.3.- Connection drawing for the CVM-BD-420-..

a.- Connection diagram of the CVM-BD-420-4 & CVM-BD-420-8 for a low voltage, three phase network.

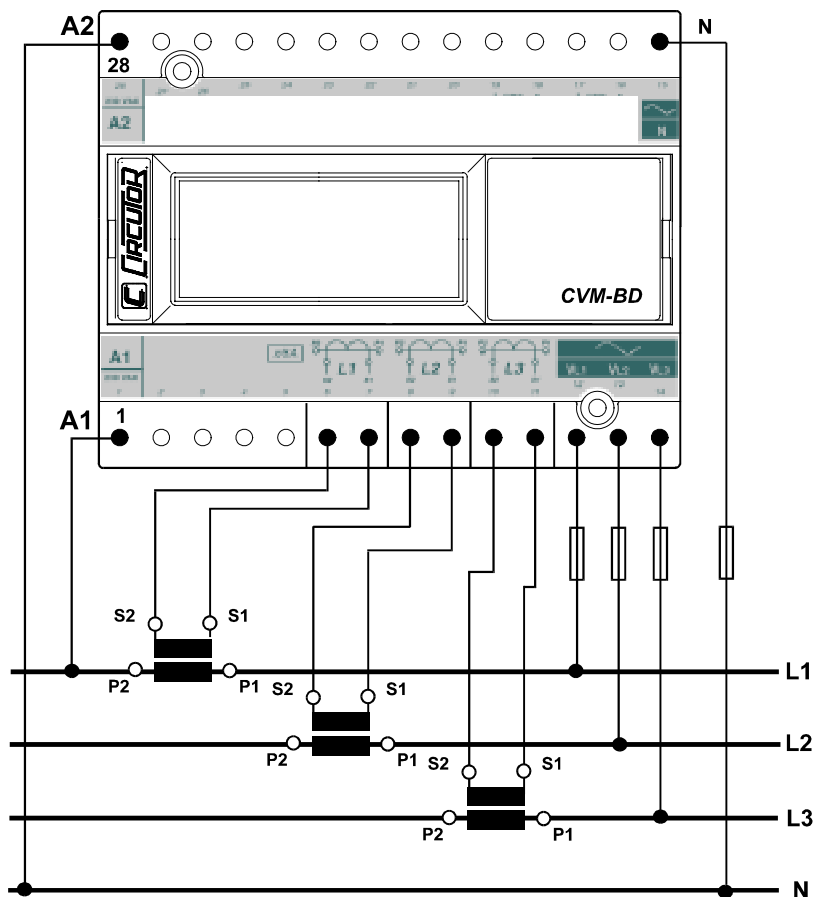

IMPORTANT REMARK! If power = 0 is shown for any of the phases (codes 03, 09 and 15) and voltage and current are not zero for this phase, check out following points:

- Assure that L1, L2 and L3 phases coincide in voltage and current.
- Correct polarity? Reverse the current transformer placed at this phase.

b.- CVM-BD-420-4 & CVM-BD-420-8: 3 current transformers + two voltage transformer :

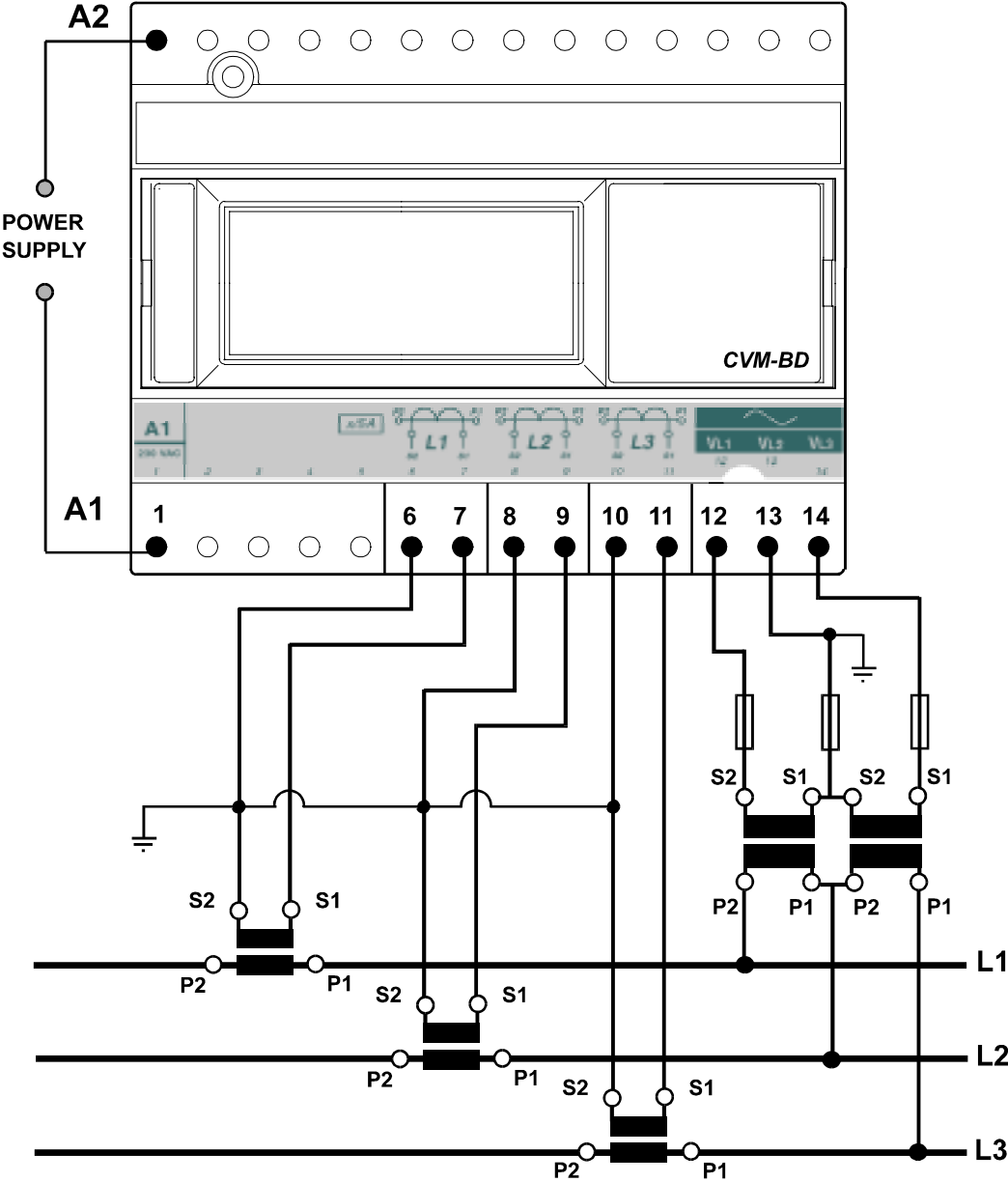

c.- **CVM-BD-420-4 & CVM-BD-420-8** : Two current transformers + 2 voltage transformers.

S2 of the current transformer grounded to earth

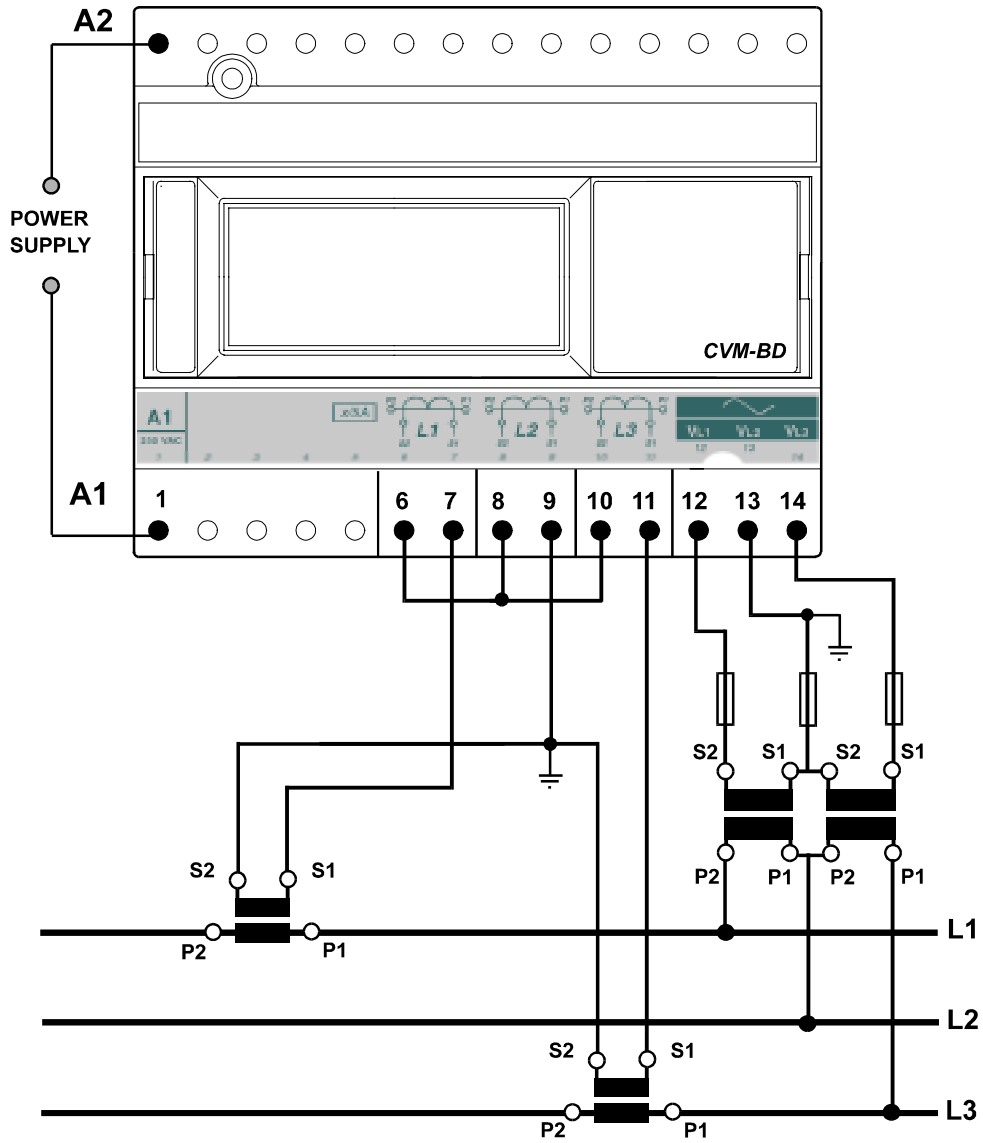

4.- OPERATION MODE

The instrument has a display with three lines (10 characters every line).

When you switch on the power supply of the CVM-BD-420-.. you will see on the display "Circ CVM-BD-..." (program version) and following you will read "CARD TYPE xxxx" (identification of the output options). After some seconds the instrument is ready to work, showing one of the possible screens.

The display indicates the parameter presently shown.

display

The first display shows the voltage of phase L1 (V1), the voltage of phase L2 (V2) and the voltage of phase L3 (V3).

220	V12
220	V23
220	V31

If you press the "**display**" key, we are now reading the CURRENT values for each phase (A1, A2, A3). However, this screen can be configured in order to display other different parameters.

When pressing again the "**display**" key, we will see on display the three previously programmed parameters (see point 5.5. in the SET-UP section).

If you press the "**display**" key again you repeat the above mentioned process (you can see 1 to 18 displays depending of the previous set-up).

max

Pressing the "**max**" key, the maximum values for the parameters being shown appear in the displays.

xxxx	MAX
xxxx	MAX
xxxx	MAX

This function is only valid while you keep pressing the "**max**" key. If you stop pressing the key the instantaneous values appear again.

min

Pressing the "**min**" key, the minimum values for the parameters being shown appear in the displays.

xxxx	MIN
xxxx	MIN
xxxx	MIN

This function is only valid while you keep pressing the "**min**" key. If you stop pressing the key the instantaneous values appear again.

Reset

Pressing the "**reset**" key the system is reset. This is equivalent to switch off the power supply of the instrument. The stored maximum and minimum values will be automatically deleted from the internal memory.

If you are in the setup process and press the "**reset**" key, you exit it without saving any modification that you have done and making a reset of the system.

5.- SETUP

To access into the **setup menu** just follow these steps:

- (a) Connect (supply) the instrument.
- (b) Press the two green buttons (**max**, **min**) simultaneously.

You will see during a few seconds the word "**set**". It means that we are in the setup process. Then we go along the different options, step by step:

5.1.- Phase-to-Phase or Phase-to-Neutral voltages

After the word "**set**" you will see on the three displays the voltages of the phases L1, L2, L3.

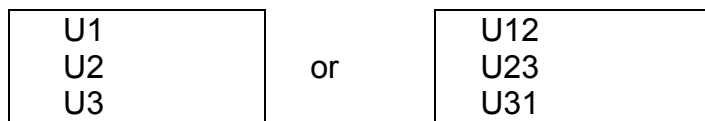

Phase to Neutral Voltages: U1 , U2 , U3

Phase to Phase Voltages : U12 , U23 , U31

a.- To select one of the voltage options just press the green key "**max**" and both options will appear alternately.

b.- When you get in the display the wished option just press the "**display**" key to validate it and access to the next setup option.

5.2.- Voltage Transformer Primary

On the screen we read the word "SET U P" followed by 6 digits. They allow us setting the primary of the voltage transformer.

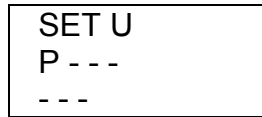

```
SET U
P ---
---
```

Last digit of the first display indicates "U" (Voltage) and first digit of the second display indicates "P" (Primary). It means that we can set the primary of the voltage transformer. To avoid mistakes the Voltage red LEDs remain lit on.

a.- To write or modify the value just repeatedly press the "**max**" key and the blinking digit value will be increased.

b.- When the value on screen is the proper one, we can pass to the next digit by pressing the "**min**" key in order to modify the other values.

c.- When the blinking digit is the last one, pressing the "**min**" key we go back to the initial value: set values can be again modified.

d.- Press "**display**" to pass to the next setup option.

5.3.- Voltage Transformer Secondary

We can now set the value of the secondary of the voltage transformer. Only three digits are available:

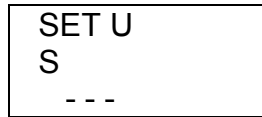

```
SET U
S
---
```

Same process as in point 5.2:

- "**max**" key: Allows us modifying the value of the blinking digit. Each time it is pressed the value is increased.
- "**min**" key: Allows us the validation of the blinking digit and going to the next one.
- Press "**display**" to pass to the next setup option.

If the CVM-BD-420-.. is directly connected to the mains (without voltage transformer) the values of primary and secondary must be the same, for instance 000001/001.

5.4.- Current Transformer Primary

"SET A P" and five digits appear on screen allowing us to set the primary of the current transformer. The current green LEDs light on to avoid mistakes.

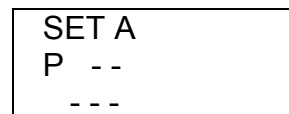

```
SET A
P --
---
```

The procedure is the same one done at the previous sections with the "**max**", "**min**" and "**display**" keys.

NOTES:

- The maximum programmable value is 10.000
- The secondary of the current transformers is not programmable. It is automatically taken as 5 A (... / 5 A ac)

5.5.- Parameter SETUP

This option allows to program until 51 optional parameters that you can see on the display through 17 possible pages (3 parameters per each page). The CVM-BD-420-.. firstly inquires whether you want the default parameter selection.

 "**max**" key : you can select YES or NO. The "**display**" key allows the validation of the selected option.

dEF PAGE YES

5.5.1.- Select "YES" to program the default parameters. In this case , it pass to the next option (5.6.- First Page SET-UP)

5.5.2.- If you select "NO" , it allows programming the parameters that you want to see on the display. Every new page, it asks if you want to continue this set-up .

SET PAGE NUMBER YES xx

<--- page N°

- If you select "SET PAGE YES" , you can program the desired parameters in this page :

xx	A1
xx	A2
xx	A3

Parameter code (set-up) / Parameter symbol

SET-UP :

- "**max**" key : Allows us modifying the value of the blinking digit. Each time it is pressed the value is increased.

- "**min**" key : Allows us the validation of the blinking digit and going to the next one.

Each display has two digits to select the desired parameters among the ones in the attached code chart:

Parameter	Symbol phase L1	Code	Symbol phase L2	Code	Symbol phase L3	Code
Single voltage	V 1	01	V 2	07	V 3	13
Current	A 1	02	A 2	08	A 3	14
Active power	kW 1	03	kW 2	09	kW 3	15
Inductive power	kvarL 1	04	kvarL 2	10	kvarL 3	16
Capacitiva power	kvarC 1	05	kvarC 2	11	kvarC 3	17
Power factor	PF 1	06	PF 2	12	PF 3	18

Three phase single voltage	Vav III	19	Frequency	Hz	25
Three phase current	Aav III	20	Three ph. apparent power	kVA III	26
Three phase active power	kW III	21	Ph-Ph voltage L1- L2	V 12	27
Three. ph. inductive power.	kvarL III	22	Ph-Ph voltage L2 - L3	V 23	28
Three ph. capacitive power	kvarC III	23	Ph-Ph voltage L3 - L1	V 31	29
Three ph. power factor.	PF III	24	Three ph. Ph-Ph voltage	Vc III	30

Date/ TIME dd/mm/yy hh:mm:ss	TIME	31
---------------------------------	------	----

Active energy	kW.h	32
Reactive energy (inductive)	kvarh.L	33
Reactive energy (capacitive)	kvarh.C	34
Demand power (kW, kVA, AIII)	Pd	35
Active energy generated	kW.h --	36
Reactive energy (inductive) gen.	kvarh.L --	37
Reactive energy (capacitive) gen.	kvarh.C --	38

Parameter	Symbol phase L1	Code	Symbol phase L2	Code	Symbol phase L3	Code
Voltage harmonic distortion	THD V1	54	THD V2	55	THD V3	56
Current harmonic distortion	THD A1	57	THD A2	58	THD A3	59

- For passing to the next page , press "**display**". In this case the CVM-BD-420-.. inquires again:

SET PAGE NUMBER YES xx
--

- If you select "SET PAGE YES" , you can set-up a next page.

- If you don't want to set-up more pages, **select "SET PAGE No"**, and it pass to the next set-up option (5.6.- First Page SET-UP). You can see the first page of voltages and all the programmed pages .

5.6.- First Page SET-UP

This option allows selecting among **fixed or rotary page**:

a.- **Fixed page** : the page is changed pressing the "**display**" key. The page among the available ones that we want to see when the CVM-BD-420-.. is powered (or a reset is made) can be selected.

b.- **Rotary pages** : the page changes to the next one automatically every 5 seconds. ("*SET AUTO PAGE : Rotate page select*" option).

Set-up :

- The "**max**" key allows modifying the selected page. The display shows the different possible pages.

SET	xx
AUTO	xx
PAGE	xx

 <-- *set-up parameters*

- The "**display**" key allows the validation of the chosen option.

5.7.- Maximum power demand

Push the key "**display**" and the following screens will appear by display:

- 1.- DEMAND PERIOD (**1 to 60 min.**) ("SET Per xx")
- 2.- PARAMETER TO CONTROL ("SET Pd xx")

Three phase active power	kW III	21
Three phase apparent power	kVA III	26
Three phase average current	AavIII	20

Value of power integrated during the programmed demand period.

- 3.- CLEAR MAXIMUM VALUE IN MEMORY ("CLr Pd xx") **no** or **YES**

PROGRAMMING MODE:

- "**max**" key: allows choosing the different available options.
- "**min**" key: allows the validation of the blinking digit and go forward to the next digit (only for the "SET Per xx" option).
- To pass to the next option press "**display**".

If you don't want to modify anything, just press the "**display**" key three times without modifying any value.

- **Display:** If you program the MAXIMUM POWER DEMAND option, **parameter 35**, the following appears by display (depending on the pressed key):

display	<i>Present value of the demand power meter (Sliding Window, according to the set demand period) updated every second.</i>
max	<i>MAXIMUM integrated value (since last reset)</i>
min	<i>HOUR : MINUTE DAY : MONTH ("HH.MM DD/MM") when this maximum has occurred</i>

5.8.- DATE / TIME SETUP



Pressing the "**display**" key we will see in the CVM-BD-420-.. screen the following:

- 1.- DAY : MONTH ("SET day dd:mm")
- 2.- YEAR ("SET YEAR xxxx ") 4 digits
- 3.- HOURS : MINUTES ("SET HOUR hh:mm")

For their setup:

- "**max**" key: Allows modifying the value of the blinking digit.
- "**min**" key: Allows the validation of the blinking digits and go to the next one.
- To pass to the next option press "**display**".

If you don't want to modify the time, just press three times "**display**" without making any modification.

- **Display**: If you select the parameter 31, following appears by display:

display	HOUR .MINUTES
max	DAY. MONTH
min	MINUTES . SEC.

5.9.- Clearing energy counters

On display we see "CLR ENER no" (Clear energy counters).

- "**max**" : To select "YES" or "no"
 - "**display**" : To validate the selected option. Once finishing this option, all the modifications that we have done are saved in memory and the setup process is finished.

- **Display** : If any of the energies is programmed (kWh, kvarhL or kvarhC), it is displayed as follows:

[display]	XXXX kW.h	<i>4 counter digits (more significant) / units</i>
[max]	XXX XXX. XXX	<i>complete counter</i>
[min]	XXXX (1)	<i>4 digits / Tariff type (1, 2 or 3)</i>

Example : If the accumulated energy is 32.534,810 kWh, it will be displayed as follows:

[display]	2534 kW.h
[max]	32534. 810
[min]	2534 (1)

5.10.- 4 - 20 mA outputs: CVM-BD-420-4 (4 analog outputs) and CVM-BD-420-8 (8 analog outputs)

With these outputs we can configure the CVM-BD420 to give an output of **4 - 20 mA d.c. or of 0 - 20 mA d.c. (resolution of 4.000 points)** proportional to any of the parameters measured by the CVM-BD, **with the ability of setting the scale (offset and full scale).**

On the CVM-BD-420-.. screen following messages appear at this SET-UP point (provided the right module is connected to the equipment):

a.- Parameter choice:

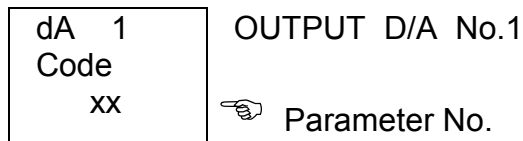

- "**max**" -- "**min**" keys: allow the selection of any parameter from 1 to 30, the 35, or from 54 to 59.
- "**display**" key: validates the selected option and passes to the next setup screen.

b.- Selection of 0 - 20 mA or 4 - 20 mA :

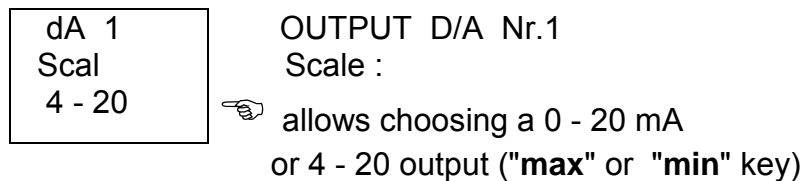

- "**display**": to validate the selected option and pass to the next setup screen.

c.- Scale offset:

Value of the parameter that we assign as the zero of the scale.

dA 1 Zero x.XXX

OUTPUT D/A No.1
Zero of the scale:



allows choosing the zero of the scale
(four digits with floating decimal point)

- "**max**" key: it allows modifying the value of the blinking value.
Every time it is pressed the number is increased.

- "**min**" key: it allows validating the blinking value and go to the next digit.

NOTE : When you arrive at the last digit, you can move the position of the decimal point with the "**max**" key.

- "**display**": to validate the selected option and pass to the next setup screen.

d.- Full scale: Value of the parameter to which we assign the 20 mA.

dA 1 F.ESC x.XXX

OUTPUT D/A No.1
Full scale:



allows choosing the full scale (20 mA)
(four digits with floating decimal point)

Proceed as in the previous section.

- To access the next option, press "**display**": setup options for the rest of analog outputs will appear up. Setup procedure is similar for any output.

1.- Output calculation:

Resolution = $\frac{20 - \text{Zero}}{\text{F. scale} - \text{offset}}$	Offset & f. scale = defined by the user Zero = 0 mA or 4 mA
MA = ((F. scale - offset) x Resolution) + Zero	
MV = mA x ohms	mV (100 ohms) = mA x 100

- Maximum load is:
 - CVM-BD-420-4:400 Ω
 - CVM-BD-420-8:300 Ω

- The maximum allowable offset is a value equal to the 90% of the full scale.

- **Output of the power factor parameter (P.F.):**

0/4 mA -----	-----20 mA
+0.00 Ind. 1.00	Cap. - 0.00

2.- Default full scale:

<i>Parameter</i>	<i>Condition</i>	<i>Full scale (20 mA)</i>
Voltages (V)	Primary < 500	Primary x 500 /secondary
	Primary > 500	Voltage primary
Currents (A)		Current primary
Powers (kW)	For one phase	voltage primary x current primary / 1000
	Three phase value	voltage primary x current primary x 3 / 1000
Frequency (Hz)		65
P.F.		- 0.00

6.- TECHNICAL FEATURES

Power supply : see specifications on the CVM-BD-420-... rear

- **CVM-BD-420-...**: Single phase 230 V a.c.
Voltage tolerance: +10 % / -15 %
Frequency: 50 ... 60 Hz

Power consumption 6 VA
Operation temperature 0 to 50° C

Measuring Circuits :

Rated voltage 500 V a.c. Phase - Neutral / 866 V a.c. between phases
Other voltagesWith appropriate voltage transformers
Rated currentIn / 5 A (**isolated input like ITF types**)
Permanent overload1.2 In
Current input power0.6 VA

Maximum burden per 20 mA channel :

CVM-BD-420-4:400 Ω

CVM-BD-420-8:300 Ω

Accuracy class:

Voltage 0.5 % of readout ± 2 digits
Current 0.5 % of readout ± 2 digits
Power 1 % of readout ± 2 digits

Test conditions :

- Errors due to Voltage T. and Current T. are not included
 - Temperature between + 5 °C and + 45 °C
 - Power factor between 0.5 and 1
 - Measured values between 5 % ... 100 %
-

Constructive characteristics :

Box type : Self-extinguishing, plastic casing
Connection : Metallic terminals with "posidraft" screws
Fixing : Fitted onto symmetrical DIN 46277 (EN 50022) rail
Screw fixing (Passing hole Ø 4,2 mm).
Frontal cover : Lexan
Protection : Built-in relay : IP 41
Terminals : IP 20
Dimensions : 140 x 70 x 110 mm (8 modules relay as per DIN 43 880)
Safety : Category II , as per EN-61010
Standards : EN 60664, EN 61010-1, EN 61036, IEC 60801 , IEC 60571-1,
EN 50081-1, EN 50082-1, VDE 110 , UL 94

Dimensions :

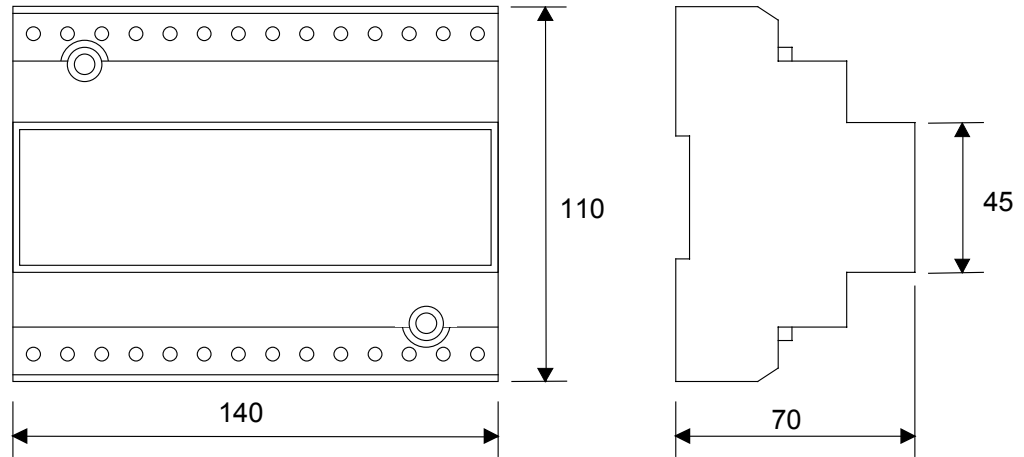

7.- SAFETY CONSIDERATIONS



All installation specification described at the previous chapters named INSTALLATION AND STARTUP, INSTALLATION MODES and SPECIFICATIONS.

Note that with the instrument powered on, the terminals could be dangerous to touching and cover opening actions or elements removal may allow accessing dangerous parts. This instrument is factory-shipped at proper operation condition.

8.- MAINTENANCE

The CVM-BD-420-.. does not require any special maintenance. No adjustment, maintenance or repairing action should be done over the instrument open and powered and, should those actions are essential, high-qualified operators must perform them.

Before any adjustment, replacement, maintenance or repairing operation is carried out, the instrument must be disconnected from any power supply source.

When any protection failure is suspected to exist, the instrument must be immediately put out of service. The instrument's design allow a quick replacement in case of any failure.

9.- TECHNICAL SERVICE

For any inquiry about the instrument performance or whether any failure happens, contact to CIRCUTOR's technical service.

*CIRCUTOR S.A. - Aftersales Service
c / Lepanto, 49
08223 - TERRASSA - SPAIN
Tel - + 34 -93 - 786 19 00*