

**CVM-MINI-LON POWER ANALYZER**



**CVM-MINI-LON** is an instrument that measures, calculates and displays the main electrical parameters in three-phase industrial power grids (balanced or unbalanced). The measurement is taken as a RMS value through three AC voltage inputs and three AC current inputs (through current transformers,  $I_N/5A$  or  $I_N/1A$ ). The measured and calculated parameters are shown in the table of variables.

This document provides the instructions for use and describes the operation of the **MINI-LON** analyzer. It can be downloaded from CIRCUTOR's web site: [www.circutor.com](http://www.circutor.com)

**!** Before performing any maintenance operations, connection modifications, repairs, etc., you must disconnect the unit from the power supply. If you suspect an operational fault in the unit or in its protection system, remove the unit from service. The design of the unit makes it easy to replace in the event of a fault.

**1.- PROGRAMMING (SETUP menu)**

(Hold down the SETUP key for 5 seconds)

- The **max** key validates the data and skips to the next menu.
- The **max** key can be used to select the various menu options or increment the digit when entering variables.
- The **min** key is used to move the cursor between digits.

The various options are described below in sequence.

**1.1.- Primary winding of the voltage transformer**

The screen displays "SET P<sub>H</sub>" followed by 6 digits, which can be used to program the primary winding of the voltage transformer (1 to 100,000).

**■ LIST OF VARIABLES AND ALARM CODES FOR CVM-MINI-LON**

➤ If you do not wish to establish a variable, set Var. No. = 00.

Magnitude	Symbol	Code L1	Code L2	Code L3
Phase-neutral voltage	V	01	06	11
Current	A	02	07	12
Active power	kW	03	08	13
Reactive power -(Ind/Cap)	kvar	04	09	14
Apparent power	kVA	38	39	40
Power factor	PF	05	10	15
% THD V	THD V	25	26	27
% THD A	THD A	28	29	30

Magnitude	Symbol	Code	Magnitude	Symbol	Code
Active three-phase power	kW III	16	Neutral current	$I_N$	37
Three-phase inductive power	kvarL III	17	Max. demand (L1)	Md (Pd)	35*
Three-phase capacitive power	kvarC III	18	Max. demand (L2)	Md (Pd)	42*
three-phase $\cos \varphi$	$\cos \varphi$	19	Max. demand (L3)	Md (Pd)	43*
Three-phase power factor	PF III	20	Active energy	kW.h III	31
Frequency (L1)	Hz	21	Inductive reactive energy	kvar-h L III	32
Phase-phase V L1- L2	V12	22	Capacitive reactive energy	kvar-h C III	33
Phase-phase V L2- L3	V23	23	Apparent energy	KVA.h III	44
Phase-phase V L3- L1	V31	24	Active energy generated	Kw-h III -	45
Apparent power	kVA III	34	Inductive energy generated	Kvar-h L III -	46
Maximum demand	Md (Pd)	35	Capacitive energy generated	Kvar-h C III -	47
Three-phase current	AIII	36	Apparent energy generated	KVA.h III -	48
Temperature	°C	41			

\*These variables are only valid when the maximum current demand per phase has been programmed.

**1.2.- Secondary winding of the voltage transformer**

The screen displays "SET P<sub>H</sub>" followed by 3 digits, which can be used to program the secondary winding of the voltage transformer (1 to 999).

**1.3.- Primary winding of the current transformer**

The screen displays "SET P<sub>H</sub>" followed by 5 digits, which can be used to program the primary winding of the current transformers (1 to 10,000).

**1.4.- Secondary winding of the current transformer**

The screen displays "SET SE<sub>C</sub>" followed by number 5 or 1, which can be used to program the ratio of the secondary winding of the current transformer installed ( $S=I_N/5A$  /  $I=I_N/1A$ ).

**1.5.- Measurement in 2 or 4 quadrants (consumption and/or generation).**

The screen displays "SET Q<sub>Ad</sub>"

(2=Consumption / 4=Consumption and Generation)

**1.6.- Programming the Maximeter:**

- Electrical magnitude to be controlled: ("SET Pd Code xx"):

None		00
Active three-phase power	kW III	16
Apparent three-phase power	kVA III	34
Three-phase current	AIII	36
Current per phase	A1-A2-A3	R-ph

Value of the integrated magnitude in a programmed period.

- Integration period (1...60 minutes): "Pd Per 15"
- Deleting the maximum value recorded in Pd: ("CL- Pd no") "no" or "YES".

**1.7.- Hide or display programming windows**

This option can be used to select the display format of the pages ("DEF Page YES / no"):

- YES | Standard: all electrical magnitudes are displayed.
- no | Custom: use the "YES" or "no" option to select the pages you wish to display when the unit is on.

**1.8.- Initial start screen programming**

This option can be used to select the screen and display screen selection mode ("set inT page"):

- Fixed page: selects the first page displayed when powering (or after RESET) the **CVM-MINI-LON**.
- Rotating screens: selecting the rotating screens option (when all electrical magnitudes are flashing), will begin automatic page rotation, where each page is displayed every 5 seconds.

**1.9.- Programming the disconnection time of the "backlight"**

("dSP dFF"): Programming the time in seconds after which the display of the **CVM-MINI-LON** will turn off (low consumption) after the last key was pressed. If this value is set to 00, the backlight will be permanently lit.

**1.10.- Resetting the energy meters**

The display shows "CL- E<sub>E</sub>" "YES" or "no" (Delete energy meters).

**1.11.- THD or d Programming**

Two different types of Harmonic Distortion can be programmed ("SET H<sub>d</sub> d"):

- d %: harmonic distortion value when compared to the fundamental value.
- Thd %: harmonic distortion value when compared to the RMS value.

**1.12.- Additional screen with transistor alarm outputs**

("Out 1 Code" / "Out 2 Code") The transistor output of the **CVM-MINI-LON** is programmed with these outputs for the following:

- Impulse every n kW.h or kvar.h (Energy): The value is programmed in kW.h, corresponding to an impulse (with a duration of 100 msec.): kW.h / 1 impulse or kvar.h / 1 impulse. Maximum of 5 imp/sec (see codes of the variable).
- ALARM Conditions: The variable controlled, maximum and minimum values and delay for each transistor output are programmed (see variable codes).

Note: The list of variables appears on the table shown below.

**2.- Service PIN Identification**

**CVM-MINI-LON** has a built-in "service button" (svc) on the front panel to send its unique identifier in broadcast format.

The identification, configuration and connection (bindings) of the network variables to the different system equipment can be carried out with the use of LNS tools of the **CARE** or **LONMAKER** type. The required device drivers are provided in electronic format (file XIF and Functional Profile Template).

You can connect the **CVM-MINI-LON** to a PC or DAC system with the help of a network interface or USB, Ethernet or similar controller. It can be even coupled to the networks using other protocols, such as MODBUS, BACnet, etc

In addition, some variables provide reference to the three phases at the same time. If you have selected one of these variables, the alarm will be activated when any of the three phases meets the programmed conditions.

Magnitude	Symbol	Code	Magnitude	Symbol	Code
Phase-neutral voltages	V1 or V2 or V3	90	Power factors	PF1 or PF2 or PF3	94
Currents	I1 or I2 or I3	91	Phase-phase voltages	V12 or V23 or V31	95
Active power	kW1 or kW2 or kW3	92	% THD V	THDV1 or V2 or V3	96
Reactive power	kvar1 or kvar2 or kvar 3	93	% THD I	THDI1 or I2 or I3	97
Apparent power	kVA1 or kVA 2 or kVA 3	98			

**■ FOUR QUADRANTS OF THE CVM-MINI-LON**

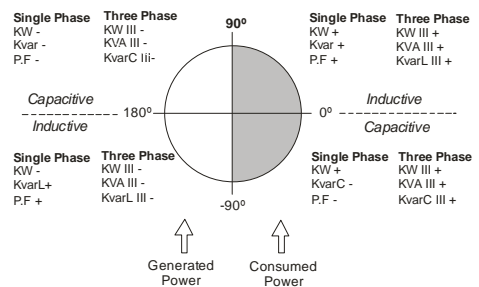

**3.- CVM-MINI-LON COMMUNICATIONS**

One or more **CVM-MINI-LON** analyzers can be connected to a **LonWorks** network through a twisted pair connection, operating at a data transmission speed of 78 Kbits per second.

The device is connected to the bus with a Neuron chip (*Free Topology Transceiver*) and an Echelon FT-10 isolating transformer, per LonTalk protocol specifications (ISO/IEC 14908, ANSI/EIA 709.1). This communications protocol can be used to access all parameters expressed on the table of variables.

**3.1.- Connections**

The **LonWorks** bus is connected with two wires to terminals A and B, as shown in the figure. This is a non-polarized bus, so the twisted pair may be connected in either direction. Any type of connection structures can be generated (*bus, star, ring, tree or a mix of these*), with up to 128 devices and a distance of 500 metres per network segment.

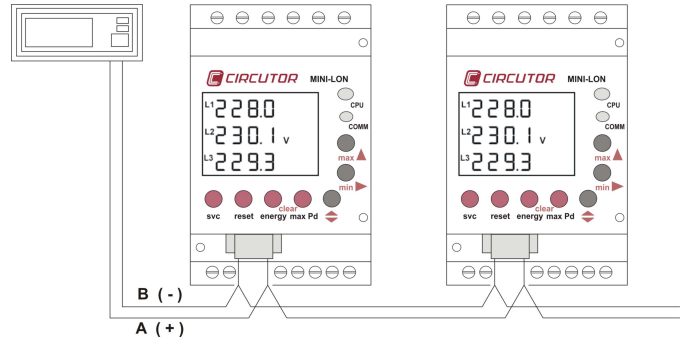

**4.- TECHNICAL SPECIFICATIONS**

<p><b>Power circuit:</b></p> <ul style="list-style-type: none"> <li>- Single-phase:</li> <li>- Voltage tolerance:</li> <li>- Frequency:</li> <li>- Maximum consumption:</li> <li>- Working temperature:</li> <li>- Humidity (non-condensing):</li> </ul>	<p><i>ac Version.</i></p> <p>230 Vac -15% / +10%</p> <p>50 - 60 Hz</p> <p>3.0 VA</p> <p>-10°C ..... +50°C</p> <p>5% ..... 95%</p>	<p><i>Plus version: ac &amp; cc</i></p> <p>85..265 Vac / 95..300 Vcc</p> <p>50 - 60 Hz (AC mode)</p> <p>3.0 VA</p> <p>-10°C ..... + 50 ° C</p> <p>5% ..... 95%</p>	<p><b>Metering circuit:</b></p> <ul style="list-style-type: none"> <li>- Nominal voltage: phase-neutral / between phases</li> <li>- Frequency:</li> <li>- Nominal current:</li> <li>- Permanent overload:</li> <li>- Voltage consumption of the circuit:</li> <li>- Current consumption of the circuit: ITF / Shunt</li> </ul>	<p>300 Vac / 520 Vcc</p> <p>45 ~ 65 Hz</p> <p><math>I_N / 5 A</math> or <math>I_N / 1 A</math></p> <p>1.2 In</p> <p>0.7 VA</p> <p>0.9 VA / 0.75 VA</p>
<p><b>Mechanical features:</b></p> <ul style="list-style-type: none"> <li>- Case material:</li> <li>- Protection:</li> <li>- Fitted unit (frontal):</li> <li>- Non-fitted unit (sides and rear cover):</li> <li>- Dimensions (mm):</li> <li>- Weight:</li> </ul>	<p>V0 self-extinguishing plastic</p> <p>IP 51</p> <p>IP 31</p> <p>85 x 52 x 70 mm (3 steps)</p> <p>210 g</p>		<p><b>Features of the output transistors</b></p> <ul style="list-style-type: none"> <li>- Type: Opto-isolated transistor (switch open).</li> <li>- Maximum operation voltage:</li> <li>- Maximum operation current:</li> <li>- Maximum frequency:</li> <li>- Impulse duration:</li> </ul>	<p>NPN</p> <p>24 Vdc</p> <p>50 mA</p> <p>5 impulses / second</p> <p>100 ms</p>
<p><b>Accuracy Class:</b></p> <ul style="list-style-type: none"> <li>- Voltage:</li> <li>- Current:</li> <li>- Power / Energy:</li> </ul> <p>Measurement sensors: Current / Voltage</p> <p>Power factor:</p> <p>Full-scale measurement margin: ITF / Shunt</p> <p>Temperature sensor: Accuracy / Working window</p> <ul style="list-style-type: none"> <li>- Temperature measurement: With / without forced ventilation</li> </ul>	<p>0.5% ± 1 digit</p> <p>0.5% ± 1 digit</p> <p>0.5% ± 1 digit</p> <p>External transformers / direct voltage</p> <p>0.5 to 1</p> <p>0.2 % ..... 120 % / 2 % ..... 120 %</p> <p>± 2°C / -10°C ..... +50°C</p> <p>+ 14.0 °C / + 3.5 °C</p>		<p><b>Safety:</b></p> <p>Installation category Class III / EN61010. Double-insulated electric shock protection class II. The equipment must be connected to a power circuit protected with type gI fuses, in compliance with IEC 269, or type M, with values from 0.5 to 1A. It must be fitted with a circuit breaker switch or an equivalent device, in order to be able to disconnect the equipment from the power supply grid. The minimum diameter of the power supply cable shall be of 1mm<sup>2</sup>.</p> <p><b>Standards:</b></p> <p>IEC 664, VDE 0110, UL 94, IEC 801, IEC 348, IEC 571-1, EN 61000-6-3, EN 61000-6-1, EN 61010-1, EN 61000-4-11, EN 61000-4-2, EN 61000-4-3, EN 61000-4-4, EN 61000-4-5, EN 55011</p>	

**5.- CONNECTIONS**

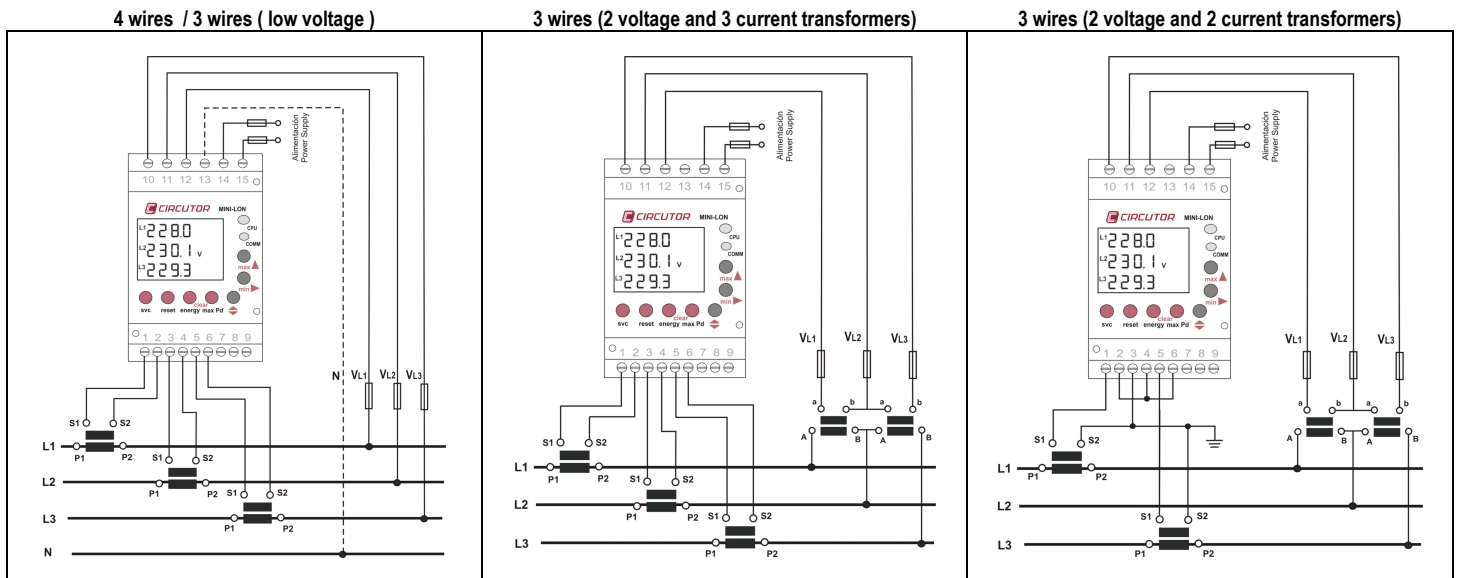

**6.- TECHNICAL SERVICE**

If you have any doubts about the operation of the unit or suspect any malfunction, contact our service staff at CIRCIUTOR, SA.

**Technical Assistance Service**  
**CIRCIUTOR, SA**

Vial Sant Jordi, s/n  
08232 – Viladecavalls (Barcelona), SPAIN  
Tel.: 902 449 459 (Spain)  
Tel.: (+34) 93 745 29 00 (out of Spain)  
email: [sat@circutor.es](mailto:sat@circutor.es)