

POWER ANALYZER CVM-MINI

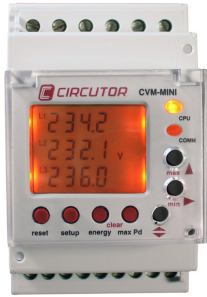

The CVM-MINI is an instrument which measures, calculates and displays the main electrical parameters for three-phase industrial systems (balanced or unbalanced). Measurements are in true effective value, via three AC voltage inputs and three AC current inputs. (via $I_N/5A$ or $I_N/1A$ current transformers). The parameters measured and calculated are shown in the variables table.

This manual is a quick guide to the use and operation of the CVM-MINI. For more information, the whole manual may be downloaded from CIRCUTOR's web page: www.circutor.es

Warning: Before any maintenance, modification to the connections, repair, etc., the equipment must be disconnected from the supply. If any operation or protection fault is suspected the equipment must remain out of service ensuring against any accidental reconnection. The equipment is designed to be changed quickly in the event of any breakdown.

1.- SETTING (SETUP menu)

(Press SETUP key for 5 seconds)

- The **max** key validates the information and moves on to the next menu.
 - The **min** key allows the different options in a menu to be selected or increases a digit where a variable is being entered.
 - The **enter** key is used to move the cursor among the digits.
- The different options are sequentially described below.

1.1.- Voltage transformer primary

On screen the words "SEt Pri U" appear followed by 6 digits. These allow the voltage transformer primary to be set (from 1 to 100,000).

1.2.- Voltage transformer secondary

On screen the words "SEt Pri U" appear followed by 3 digits. These allow the voltage transformer secondary to be set (from 1 to 999).

1.3.- Current transformer primary

On screen the words "SEt Pri I" appear followed by 5 digits. These allow the current transformer primary to be set (from 1 to 10,000).

1.4.- Current transformer secondary

On screen the words "SEt Sec R" appear followed by the number 5 or 1. These allow the installed current transformer secondary ratio to be set ($5=I_N/5A$ / $1=I_N/1A$).

1.5.- Measurement in 2 or 4 quadrants (power consumption and/or generation).

On screen the words "SEt Quad" appear (2=Power consumption / 4=consumption and generation)

1.6.- Setting the Power demand meter:

a) Electrical parameter to control: ("SEt Pd CodE"):

None		00
Three-phase active power	kW III	16
Three-phase apparent power	kVA III	34
Three-phase current	A III	36
Current per phase	A1-A2-A3	R-Ph

Integrated parameter value according to the set period.

- b) Integration period (1...60 minutes): ("Pd PEr IS")
- c) Clear maximum value recordings of Pd: ("CLR Pd no") "no" or "YES".

1.7.- Setting display or omitting screens

This option allows the page display format to be displayed ("dEF PRgE YE5 / no"):

- I. YE5 | Standard: se all electrical parameters are displayed.
- II. no | Custom: by using the "YES" or "no" option the pages to be displayed when the equipment is on are selected.

1.8.- Setting the start screen

This option allows select the screen and selection mode of display screens ("SEt InI t PRgE"):

- I. Fixed page: selects which page from the possible pages will appear first when applying voltage (or on RESETTING) to the CVM-MINI.
- II. Rotating pages: selecting rotating pages (when all of the electrical parameters flash), automatically rotates, every 5 seconds it moves on to the following screen.

1.9.- Setting the "backlight" disconnection time

("dI SP oFF"): Setting the time in seconds, after which the light on the CVM-MINI display switches off (low consumption) after a key is pressed. If 00 is set, the backlight is permanently on.

1.10.- Returning the energy counters to zero

"CLR ENEr" "YE5" or "no" (Clear energy counters) appears on the display.

1.11.- Setting THD or d

Two types of Harmonic distortion can be set ("SEt HRF d"):

- d %: value harmonic distortion with respect to the fundamental.
- Thd %: value harmonic distortion with reference to the effective value (RMS).

1.12.- Additional screen with transistor alarm outputs

("Dut E CodE" / "Dut 2 CodE") With these outputs the CVM-MINI transistor output is set for:

- I. Impulse every n kW.h or kvar.h (Energy): The value in kW.h is set corresponding to one impulse (100 msec long.): kW.h / 1 impulse or kvar.h / 1 impulse. Maximum 5 imp/sec. (see variable codes).
- II. ALARM conditions: each output is set per transistor the variable to be controlled, the maximum value, minimum value and the (delay) (see variable codes).

Note: The list of variable appears in the table below.

2.- Second CVM MINI SET UP

To access the menu where the equipment's communication may be changed:

Press the **reset** key and pressing the **setup** key for five seconds until Set-Up is entered.

Configurable parameters:

- SEt nPEr: peripheral no. 001 to 255
- SEt BRUd: (speed) 1200-2400-4800-9600-19200
- SEt PRFI: No, even, odd
- SEt bL5: (length) 8 bits
- SEt StOP: 1 or 2

Default setting: 001 / 9600 / 8 / n / 1

2.1.- Block | unblock SETUP:

If the Loc, option is selected, it is only possible to see the setting on entering SETUP and nothing may be changed. If a previously set option is to be changed, then it is necessary to enter a password. PASSWORD CVM-MINI 1234.

LIST OF VARIABLES AND ALARMS CODES FOR THE CVM-MINI

If no variable is required enter No. par.= 00.

Parameter	Symbol	L1 Code	L2 Code	L3 Code
Voltage (phase-neutral)	V	01	06	11
Current	A	02	07	12
Active power	kW	03	08	13
Reactive power -(Ind/Cap)	kvar	04	09	14
Apparent power	kVA	38	39	40
Power factor	PF	05	10	15
% THD V	THD V	25	26	27
% THD A	THD A	28	29	30

Parameter	Symbol	Code	Parameter	Symbol	Code
Three-phase active power	kW III	16	Neutral current	I_N	37
3 pha. inductive power	kvarL III	17	Max demand (L1)	Md (Pd)	35*
3 pha. capacitive power	kvarC III	18	Max demand (L2)	Md (Pd)	42*
cos φ three-phase	cos φ	19	Max demand (L3)	Md (Pd)	43*
3 pha. power factor	PF III	20	Active energy	kW.h III	31
Frequency (L1)	Hz	21	Inductive reactive energy	Kvar.h L III	32
V phase phase L1- L2	V 12	22	Capacitive reactive energy	Kvar.h C III	33
V phase phase L2- L3	V 23	23	Apparent energy	KVA.h III	44
V phase phase L3- L1	V 31	24	Active energy generated	Kw.h III -	45
Apparent power	kVA III	34	Inductive energy generated	Kvar.h L III -	46
Maximum demand	Md (Pd)	35	Capacitive energy generated	Kvar.h C III -	47
Three-phase current	A III	36	Apparent energy generated	KVA.h III -	48
Temperature	°C	41			

*Variables only valid if the Maximum Demand for current has been set per phase.

There are also some variables that refer to the three-phases at the same time. If one of these variables has been selected, the alarm will go off when any of the three-phases meet the preset conditions.

Parameter	Symbol	Code	Parameter	Symbol	Code
Voltages (phase-neutral)	V1 or V2 or V3	90	Power factors	PF1 or PF2 or PF3	94
Currents	I1 or I2 or I3	91	Voltages (phase-phase)	V12 or V23 or V31	95
Active powers	kW1 or kW2 or kW3	92	% THD V	THDV1 or V2 or V3	96
Reactive powers	kvar1 or kvar2 or kvar3	93	% THD I	THDI1 or I2 or I3	97
Apparent powers	kVA1 or kVA 2 or kVA 3	98			

FOUR QUADRANTS OF THE CVM MINI

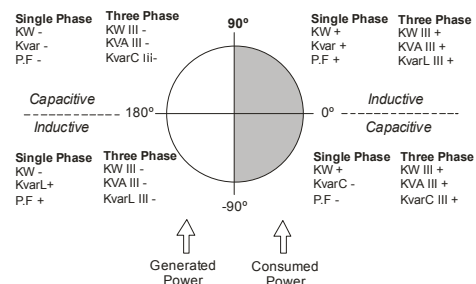

3.- CVM-MINI COMMUNICATIONS

One or more **CVM-MINI** analyzers can be connected to a computer or PLC. As well as the usual operation of each piece of equipment, this system may centralize data at one single point (*Power Studio®* System). The **CVM-MINI** has an RS-485 series communications output. If more than one analyzer is connected to one series communication bus (RS-485), it is necessary to assign to each a number or peripheral address (from 01 to 255) so that the central computer sends data on different measured or calculated recordings to those addresses.

To change the setting for the communications see section 2.

The RS-485 connection is made with woven mesh shielded communications cables, with a minimum of three wires and with a maximum distance between remote computer and the last analyzer of 1,200 metres. The **CVM-MINI** uses an RS-485 communications line which can be connected to a maximum of 32 analyzers in a serial port, in each serial port on the computer used.

The **CVM-MINI** power analyzer communicates using the **MODBUS RTU®** protocol (Pulling Question / Answer).

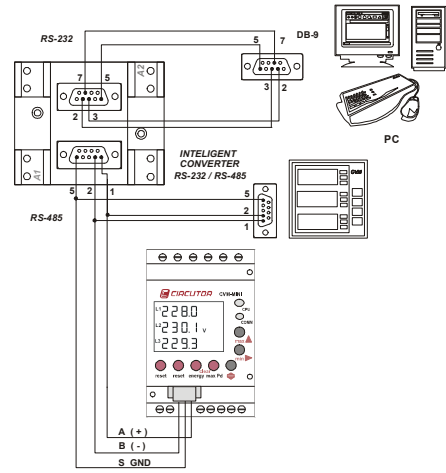

4.- TECHNICAL FEATURES

<p>Power supply circuit:</p> <ul style="list-style-type: none"> - Single-phase: - Voltage tolerance: - Frequency: - Maximum consumption: - Operating temperature: - Humidity (without condensation): 	<p><i>AC. version</i> 230 V AC. -15 % / +10 % 50 - 60 Hz 3,0 VA -10°C +50°C 5% 95%</p> <p><i>Plus version: AC. & DC.</i> 85.265 V AC / 95.300V DC. 50 - 60 Hz (AC. mode) 3,0 VA -10°C + 50 ° C 5% 95%</p>	<p>Measurement circuit:</p> <ul style="list-style-type: none"> - Rated voltage: phase-neutral / between phases - Frequency: - Rated current: - Permanent overload: - Power consumption voltage circuit: - Power consumption current circuit: ITF / Shunt 	<p>300 V AC. / 520 V AC. 45 - 65 Hz $I_N / 5 A$ or $I_N / 1 A$ 1.2 In 0.7 VA 0.9 VA / 0.75 VA</p>
<p>Mechanical features:</p> <ul style="list-style-type: none"> - Casing material: - Protection: Assembled equipment (front): Non assembled equipment (sides and rear cover): - Dimensions (mm): - Weight: 	<p>Self extinguishing V0 plastic IP 51 IP 31 85 x 52 x 70 mm (3 step) 0.210 kg</p>	<p>Output transistors features</p> <ul style="list-style-type: none"> - Type: Opto-isolated transistor (open collector). - Maximum operating voltage: - Maximum operating current: - Maximum frequency: - Impulse length: 	<p>NPN 24 V DC. 50 mA 5 impulses / second 100 ms</p>
<p>Accuracy class:</p> <ul style="list-style-type: none"> - Voltage: - Current : - Power / Energy: <p>Measurement loggers: Current / Voltage Power factor: Scale range measurement margin: ITF / Shunt Temperature sensor: Accuracy / Operating window - T^a measurement: Without / with forced ventilation</p>	<p>0.5 % ± 1 digit 0.5 % ± 1 digit 0.5 % ± 1 digit External transformers / direct voltage 0.5 to 1 0.2 % 120 % / 2 % 120 % ± 2°C / -10°C +50°C + 14.0 °C / + 3.5 °C</p>	<p>Safety: Category III - 300 V AC. / 520 AC. EN-61010 Class II double insulation against electric shock</p> <p>Standards: IEC 664, VDE 0110, UL 94, IEC 801, IEC 348, IEC 571-1, EN 61000-6-3, EN 61000-6-1, EN 61010-1, EN 61000-4-11, EN 61000-4-2, EN 61000-4-3, EN 61000-4-4, EN 61000-4-5, EN 55011</p>	

5.- CONNECTIONS

4 wire / 3 wire (low voltage)

3 wire (2 voltage transformers and 3 current transformers)

3 wire (2 voltage transformers and 2 current transformers)

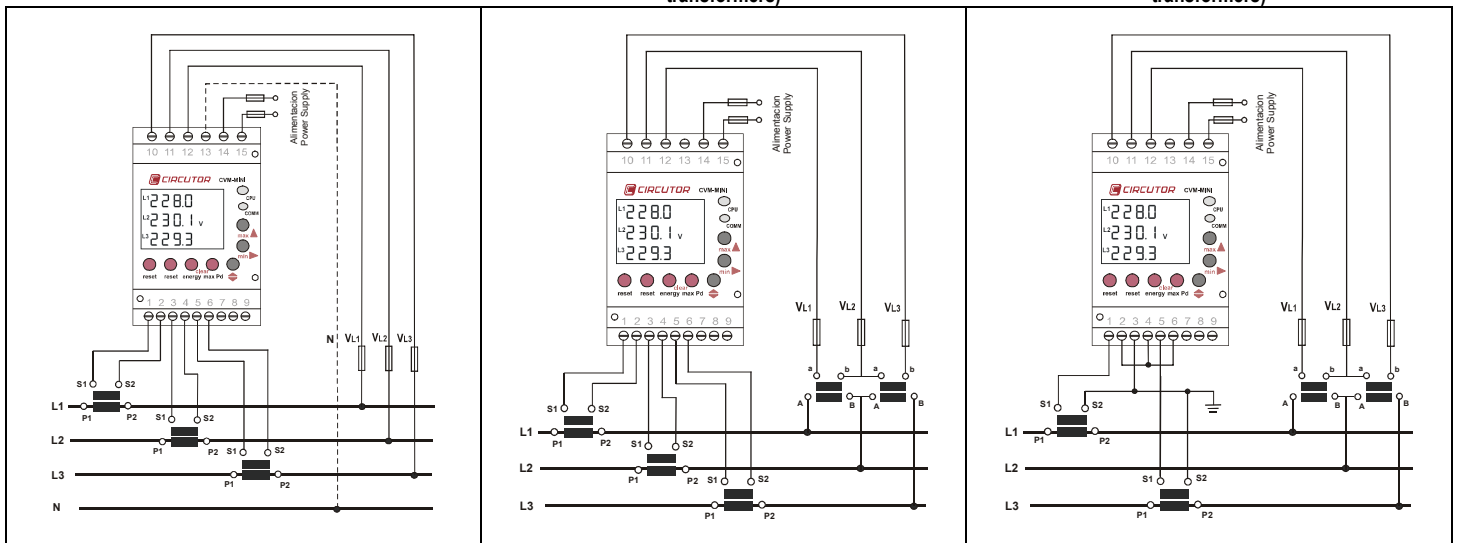

6.- TECHNICAL SERVICE

In the event of any equipment failure or any operational queries please contact the technical service of CIRCUTOR S.A.

CIRCUTOR S.A. - After sales service
 Vial Sant Jordi, s/n
 08232 - Viladecavalls (Barcelona)
 tel.: (+34) 93 745 29 00 & fax: (+34) 93 745 29 14
 E-mail: central @ circutor.es