





**FIXED-WINDOW POWER DEMAND
CONTROLLER BY ENERGY PULSES
CVM-R8D-CPP**

INSTRUCTION MANUAL

(M 981 316 / 99B)

(c) CIRCUTOR S.A.

Index	Power demand control	Page
1.-	INITIAL CONSIDERATIONS	2
1.1.-	Check the contents of your package.	2
1.2.-	Safety warnings 	2
2.-	INTRODUCTION	2
3.-	CVM-R8D-CPP DESCRIPTION	4
4.-	INSTALLATION AND STARTUP 	5
4.1.-	Installation	5
4.2.-	Connection terminals	6
4.3.-	Power demand controller connection	8
4.4.-	Connection CVM- R8 (COM1) ----- PC	10
5.-	POWER DEMAND CONTROL BY ENERGY PULSES	11
5.1.-	Operation mode	11
5.2.-	Main concepts.....	12
5.2.1.-	Allowable power	12
5.2.1.-	Remaining power	12
5.2.3.-	Hysteresis	12
5.2.4.-	Offset time	13
5.2.5.-	Minimum time for load restoring	13
5.3.-	Alarm	13
5.4.-	SETUP procedure.....	14
5.5.-	DISPLAY MODE	18
6.-	TECHNICAL FEATURES	20
7.-	SAFETY WARNINGS 	22
8.-	MAINTENANCE	22
9.-	TECHNICAL SERVICE	22

FIXED-WINDOW POWER DEMAND CONTROLLER BY ENERGY PULSES

1.- INITIAL CONSIDERATIONS

1.1.- Check the contents of your package.

This manual is aimed to familiarize de user with the installation and operation of the power demand controller type CVM-R8D-CPP, in order to get the best from its features. After receiving the instrument, please check the following points:

- a) The analyzer model corresponds with your order specifications.
- b) After unpacking, check that the instrument has not been damaged in transit.
- c) Check the package includes the instruction manual.

1.2.- Safety warnings



The manual you hold in your hands contains information and warnings that the user should strictly respect in order to guarantee a proper operation of all of the instrument functions and keep its safety conditions.

2.- INTRODUCTION

The power demand controller by energy pulses CVM-R8D-CPP monitors the average power consumed during each integration period, thus performing the adequate control actions in order to avoid the maximum demand meter of the utility to register a peak demand higher than the allowable one, but allowing the maximum performance from this power to be attained.

When the maximum demand meter records a power demand higher than the allowable one, a surcharge is assessed to the customer in the electrical energy bill.

Getting the maximum performance from the allowable power means to consume the maximum power at each moment but avoiding the maximum demand meter to register a peak demand higher then this allowable power at the end of the integration period.

A typical situation found at the industrial environment is that one when a high peak demand level is reached. Those peaks are generally provoked when loads that usually do not simultaneously run are in operation. In order to avoid surcharges, a possible solution might be to initially contract a maximum power demand higher than highest recorded peak demand, however implying a final cost rise. Another solution is to install a control system providing the user to take the appropriate actions in order to reduce the system power consumption, even by directly shedding loads.

The main features of this power demand controller can be summarized as follows:

- Fixed window: The instrument operates synchronized with the utility maximum demand meter, thus being essential in this case the pulses generated by the utility maximum demand meter. A recording period ends when a pulse is received and a new one starts.
- Measurement by pulses: The accumulated energy consumption during each integration period is determined by monitoring the pulses sent by an energy meter provided with an emitter contact or by another measuring instrument equipped with energy pulse outputs. The maximum cadence is one pulse per second, please consult us for instruments with higher cadences.
- Connection-Disconnection: Connection and disconnection actions are performed according to an internal algorithm which either optimizes the number of operations and ensures the power demand at the end of the recording period not to exceed the user-defined allowable demand.
- Linear or cyclic: User can choose between a linear or cyclic connection-disconnection mode.
- Alarm: An alarm relay advises about anomalous situations at the power demand control system.
- Diverse tariffs: Control actions can be taken according to up to three different powers (peak, valley and plain periods). The selection is done through the voltage free inputs.
- Setup: Setup procedure is done by means of either the keyboard and the display
- The main information about the instrument operation is shown on display.
- The power demand controller can act over different loads, from a minimum of only one load to a maximum of seven loads with the CVM-R8D-CPP, or up to 17 whether a CVM-R10 relay expansion peripheral is available.

3.- CVM-R8D-CPP DESCRIPTION

The CVM-R8D is a programmable control peripheral that take decisions from electrical measurements of the CVMk (serial port COM2) &/or from external signals coming through the digital and analog inputs it equips.

The CVM-R8D-CPP uses the CVM-R8 hardware for an specific application involving power demand control.

Main features:

8 output relays
2 analog inputs 0 - 2 V d.c.
6 digital inputs, voltage free contacts (20 mA - 24 V d.c.)
COM1 : RS-485 Serial port: direct connection to PC
COM2 : RS-485 Serial port: connection to the CVM (Network)
Plane cable connector to connect the CVM- R10 C expansion peripheral (10 relays + 10 digital inputs)

- Display of 1 x 8 characters (50 x 15 mm) to show numerical or alphanumerical values
- Four programmable keys (← , ↑ , ENTER & CLEAR).

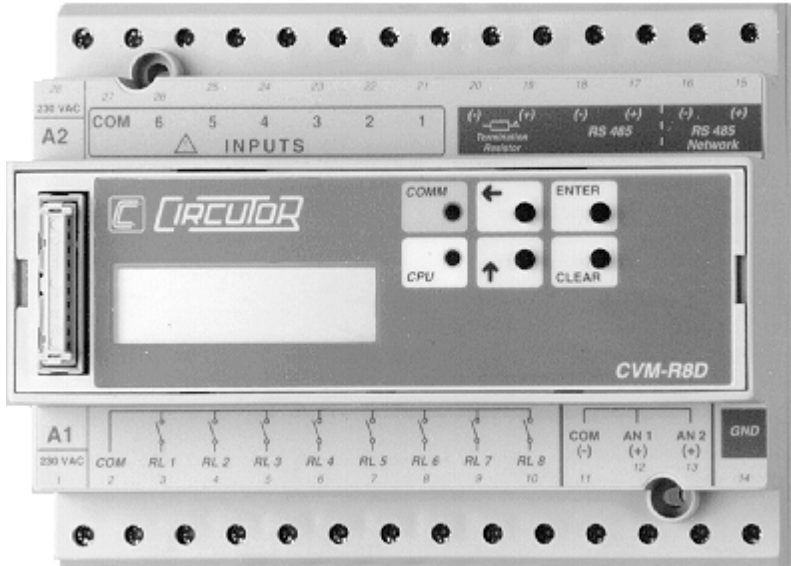

4.- INSTALLATION AND STARTUP



The manual you hold in your hands contains information and warnings that the user should strictly respect in order to guarantee a proper operation of all of the instrument functions and keep its safety conditions.

The instrument must not be powered and used until its definitive assembly in the switchgear cabinet.

Whether the instrument is not used as manufacturer's specifications, the protection of the instrument can be damaged.

When any protection failure is suspected to exist (for example, it presents external visible damages), the instrument must be immediately powered off. In this case contact a qualified service representative.

4.1.- Installation

Before powering the instrument, check following points :

(a) **Supply voltage : 230 V a.c. (+ 10 % / --15 %)**

Connection terminals A1 -A2 (Terminals 1- 28)

(b) Frequency : 50 ... 60 Hz

(c) Instrument burden : 7 VA

(d) Operation conditions :

- Operating temperature : 0 to 50°C

- Humidity : 25 to 75 % R.H. without condensation

(e) Safety : Designed to meet protection class II as per EN 61010.

Mounting:

Instrument is to be mounted on DIN rail mounting device with low dimensions.
All connections keep inside the cabinet.

Note that with the instrument powered on, the terminals could be dangerous to touching and cover opening actions or elements removal may allow accessing dangerous parts. Therefore, the instrument must not be used until this is completely installed.

The instrument must be connected to a power supply circuit protected with gl type (IEC 269) or M type fuses rated between 0.5 and 2 A. This circuit should be provided with an automatic switch (I / O) or any equivalent element to connect (ON) or disconnect (OFF) the instrument from the power supply network. The supply and measuring voltage circuits will be both connected through a wire with a minimum cross-section of 1 mm².

4.2.- Connection terminals

Terminal No	Denomination	Concept
1 - 28	A1 - A2	230 V a.c. supply
27	COM	Voltage free input common
26	6	Input No 6
25	5	Input No 5
24	4	Input No 4
23	3	Input No 3
22	2	Input No 2
21	1	Input No 1
20 - 19	Termination resistor (RT)	240 Ω resistor: adaptation of the line final impedance (bridge 20 -- 18 and other 19 -- 17)
18	--	COM1 CVM-R8 : RS-485 connection to the PC. 18 -- -----> 2 (--)
17	+	17 + -----> 1 (+) RS-485/RS-232
14	GND	14 GND -----> 5 converter
16	--	COM2 : RS-485 connection to CVM's RED module: 16 -- -----> 3
15	+	15 + -----> 4 (RED module)
14	GND	14 GND -----> 5
13	AN 2 (+)	Analog input d.c. No 1
12	AN 1 (+)	Analog input d.c. No 2
11	COM (--)	Input common
10		Relay output No 8
9		Relay output No 7
8		Relay output No 6
7		Relay output No 5
6		Relay output No 4
5		Relay output No 3
4		Relay output No 2
3		Relay output No 1
2		RELAY common

Power supply A1	INPUTS							Terminator resistor (-) (+)	RS485 (-) (+)		RS485 Network (-) (+)		
	COM	6	5	4	3	2	1		(-) (+)	(-) (+)	(-) (+)	(-) (+)	
28	27	26	25	24	23	22	21	20	19	18	17	16	15

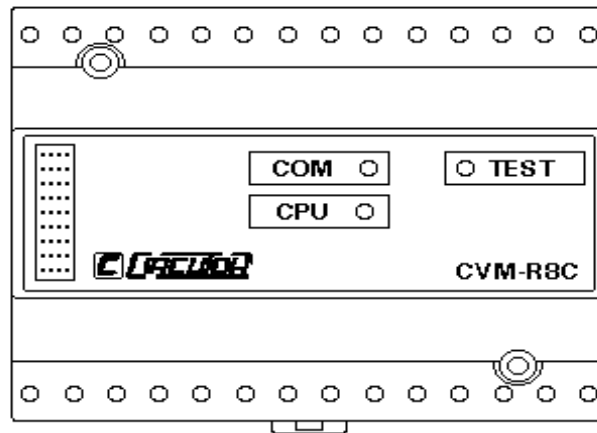

Power supply A2												GND 14	
	COM	RL1	RL2	RL3	RL4	RL5	RL6	RL7	RL8	COM (-)	AN1 (+)		AN2 (+)
1	2	3	4	5	6	7	8	9	10	11	12	13	14

4.3.- Power demand controller connection

Consider following points when connecting the instrument:

- Inputs a voltage free type. One input is activated by a short-circuit between the input common with this input.
- Energy pulses must be input through an external NO relay.
- Synchronism pulses must be input through an external NO relay.
- Outputs are electromechanical relays.
- When the instrument is powered off, all outputs are opened.
- When a load is turn on, the relay of the associated output is closed.
- When a load is turn off, the relay of its output is opened.
- Loads are consecutively connected from the output 2, i.e., if there are three loads, those must be connected in inputs 2, 3 & 4.

Function of inputs and outputs in the power demand controller by energy pulses are the following ones:

Terminal No	Denomination	Concept
27	COM	Voltage free input common
26	Input 6	Synchronism with utility demand meter
25	Input 5	Energy pulses (Maximum: 1pulse/sg)
22	Input 2	Selection of tariff 3
21	Input 1	Selection of tariff 2
10	Output 8	Load No 7 (More loads available with expansion module CVM-R10)
9	Output 7	Load No 6
8	Output 6	Load No 5
7	Output 5	Load No 4
6	Output 4	Load No 3
5	Output 3	Load No 2
4	Output 2	Load No 1
3	Output 1	Alarm
2	RELAY common	RELAY common

NOTE: Tariff 1 is the one set by default, while input 1 or 2 is not activated, control parameters correspond to tariff 1.

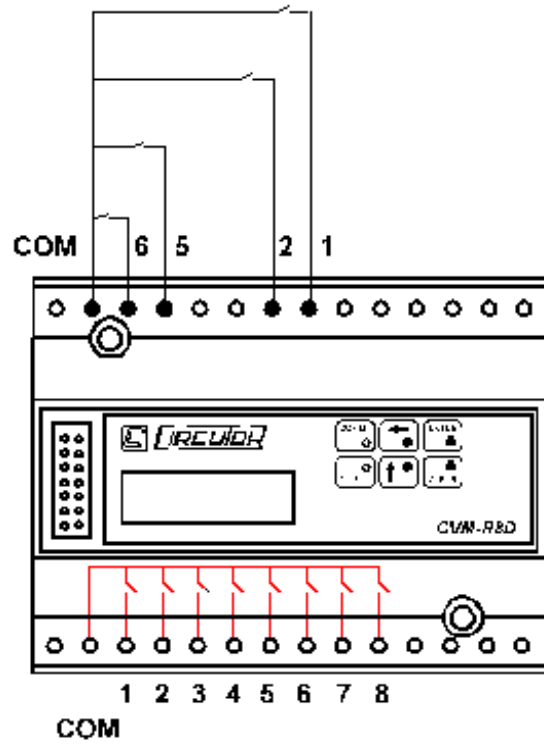

4.4.- Connection CVM- R8 (COM1) ----- PC

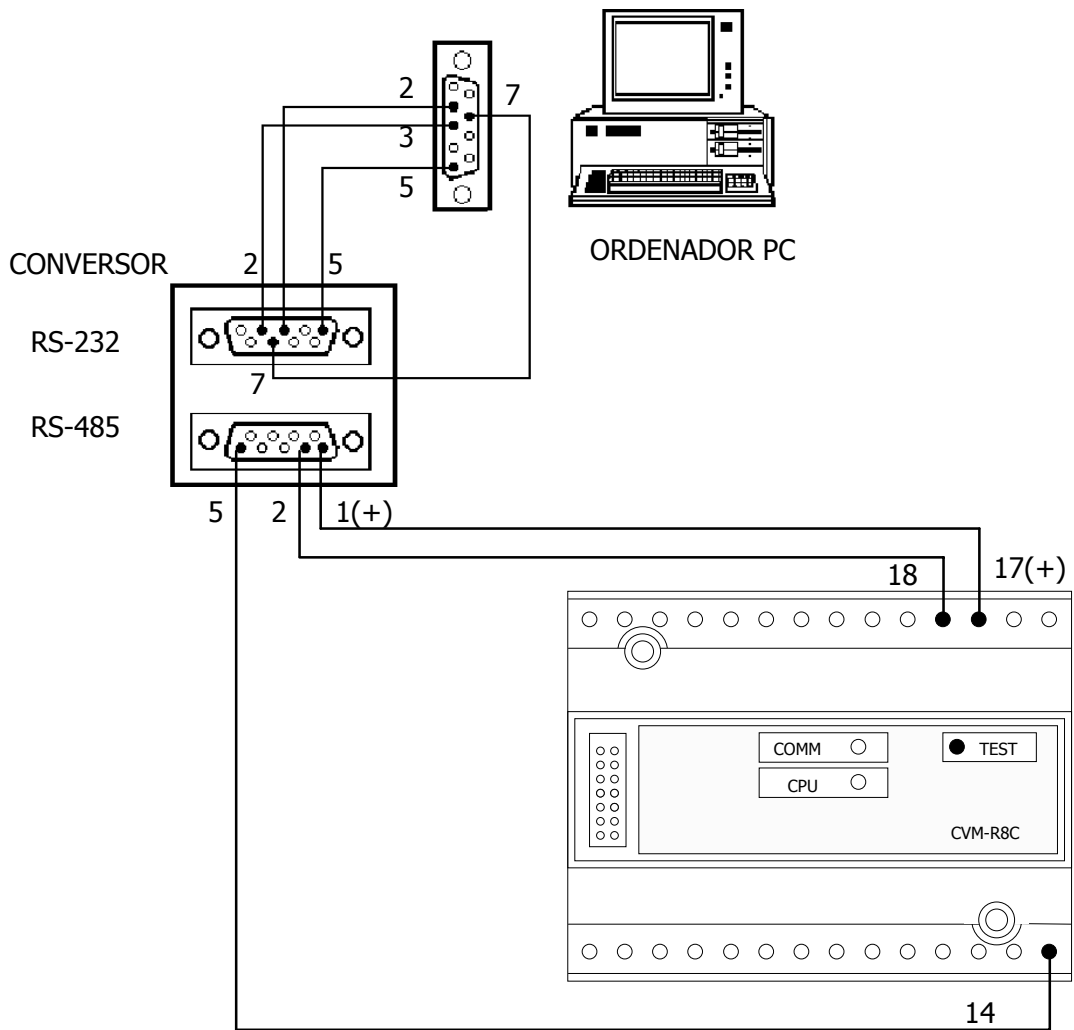

5.- POWER DEMAND CONTROL BY ENERGY PULSES

5.1.- Operation mode

The CVM-R8D is a power demand controller by fixed window and energy measurement through pulses. Main features of this power demand control system can be summarized as follows:

- The controller operates synchronized with the utility demand meter, thus being essential in this case the pulses generated by the utility demand meter. A recording period ends when a pulse is received and a new one starts. The detection is done from rising flank.
- The accumulated energy consumption during each integration period is determined by monitoring the pulses sent by an energy meter provided with an emitter contact or by another measuring instrument equipped with energy pulse outputs. The maximum frequency of pulses will be 1 pulse for second.
- In function of power demand evolution along a demand period, the instrument closes relays (ON→OFF), to directly turn off loads or to provide an alarm that informs the user about the situation. When the risk disappears, the instrument opens again the relays (OFF→ON). Connection and disconnection actions are performed according to an internal algorithm which either optimizes the number of operations and ensures the power demand at the end of the recording period not to exceed the user-defined allowable demand.
- When a load is turn on, the relay of the associated output is closed (ON), when a load is turn off this relay is open (OFF).
- When the controller is not powered, all outputs remain open (Loads turn off), to avoid the allowable user-defined power demand to be exceeded.
- The controller does not turn any load on until the first synchronism signal is received.
- The controller takes decisions about the need to turn any load off as it receive each energy pulse.
- Control actions can be taken according to up to three different powers (peak, valley and plain periods). The selection is done through the instrument inputs. Tariff 1 is the one taken by default.
- The instrument can perform load disconnection–connection actions either in a cyclical mode or based on pre-defined priorities. When working in the cyclical mode, the controller will open the relay that has remained for the longest time closed, and will close the one for the longest time open; such getting a rotation to turn loads on and off. When is based on priorities, relays are open from lower to higher priority, while they are inversely closed, i.e., from lower to higher priority.
- Whether the controller does not receive any synchronism pulse, this will activate the alarm and will switch to sliding window operation mode.

5.2.- Main concepts

5.2.1.- Allowable power

Allowable power demand according to the supply contract with the utility.

5.2.1.- Remaining power

The remaining power is the maximum power demand at facility where all loads managed by the power demand controller are turn off.

The exact calculation of the remaining power should be done by measuring the maximum demand power at the installation where all loads managed by the power demand controller are turn off. Whether this method is not possible, then this power could be calculated with the sum of all rated powers of not-controlled loads.

This parameter is essential for an effective performance of the controlling system and to guaranty the power utility meter not to record a value higher than the allowable power.

5.2.3.- Hysteresis

The hysteresis defines a difference between the points of turning on and off of loads. That is, the zone where no control operation if performed.

Supposing a 10% hysteresis is set, loads will be turn off when the accumulated demand exceeds the allowable demand, and loads will be restored when the accumulated demand is a 10% below the allowable demand.

Recommended values are:

Minimum value	4%
Many low-power loads	10%
Few high-power loads	15%

This parameter permits to suit the power demand controller according particularities of each installation:

- Whether within the same cycle many loads are turn off and later torn on again, hysteresis value should be increased in order to better determine decisions and to avoid unnecessary control operations.
- Whether the time that the controller takes to restore loads is too long, the hysteresis value can be reduced and then this time will be lowered.

It is advisable to set the hysteresis value according to the controller performance observed at each installation.

5.2.4.- Offset time

This parameter defines a time lap in which no operation will be done whatsoever. It must be entered as a percentage of the window time.

For instance, for a window time of 15 minutes, it is advisable to set 10%. In such a way we will avoid, in some cases, operations due to slope of the curve.

5.2.5.- Minimum time for load restoring

There are loads that requiring a time to be turn on again, like for instance, cooling chambers. This minimum time for load restoring is the minimum time between one load is turn off and turn on back.

You should consider:

- The programmed minimum time for load restoring will be applied for all loads. I.e., if a value of 3 min is set, all loads will be at least off during this time.
- According to above said, the time set must be the highest one among all required for each load.
- If loads do not require this time, this must be set at zero.

5.3.- Alarm

The alarm acts when:

- Whether the demand controller has not received the synchronism signal from the utility demand meter after a 10% over the set window time. This could happen due to a malfunction in the utility meter or a problem in the connection system.
- Whether even though all loads are off, the risk of exceeding the allowable demand already exist. In this situation manual actions will be required to avoid the allowable demand to be exceeded.



When the alarm trips, this will be latched until the *CLEAR* key is pressed.

5.4.- SETUP procedure

Actions associated to keys are:



- In display mode by pressing this key you access setup menu.
- When any setup parameter has been modified press this key to validate changes.

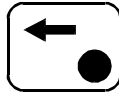

- In setup mode press this key to pass to display mode.
- When modifying a numeric parameter use this key to select the digit to be changed (units, tens, ...).



- In setup mode by pressing this key you access the next setup parameter.
- When modifying a numeric parameter use this key to increase the selected digit.
- When setting a non-numeric option use this key to select among different options.



- In setup mode by pressing this key you can edit the setup field or parameter on display.



Fields can only be edited when the parameter **CE?** (*Change Enable*) is previously set at **YES**. If this option is disable, setup parameters can only be check but not modified.



When pressing this key to edit a filed and the option **CE?** is enabled, the controller will turn all loads off.

Setup parameters:

PW1 ****

Allowable power for tariff 1 [kW].

- **Numeric field**
- **Maximum 9999 kW**

Allowable power for tariff 1. This will be the value taken as the limit when the tariff 1 is selected.

PW2 ****

Allowable power for tariff 2 [kW].

- **Numeric field**
- **Maximum 9999 kW**

Allowable power for tariff 2. This will be the value taken as the limit when the tariff 1 is selected.

PW3 ****

Allowable power for tariff 3 [kW].

- **Numeric field**
- **Maximum 9999 kW**

Allowable power for tariff 3. This will be the value taken as the limit when the tariff 1 is selected.

PUL ****

Energy per pulse [Wh].

- **Numeric field**
- **Maximum 9999 Wh**

The energy/pulse ratio. In case this parameter is not properly programmed, the demand power controller will not effectively operate.

WN.T

Integration window time [min].

- **Numeric field**
- **Minimum 1**
- **Maximum 99**

This is the utility demand period in minutes. This value is used for internal calculation process. When the demand period time is exceeded and no synchronism pulse is received, the alarm relay trips.

RP1 ****

Remaining power for tariff 1 [kW].

- **Numeric field**
- **Maximum 9999 kW**

The maximum power demand at facility, within tariff 1 billing period, when all loads managed by the power demand controller are turn off.

RP2 ****

Remaining power for tariff 2 [kW].

- **Numeric field**
- **Maximum 9999 kW**

The maximum power demand at facility, within tariff 2 billing period, when all loads managed by the power demand controller are turn off.

RP3 ****

Remaining power for tariff 3 [kW].

- **Numeric field**
- **Maximum 9999 kW**

The maximum power demand at facility, within tariff 3 billing period, when all loads managed by the power demand controller are turn off.

LDS ****

Number of loads.

- **Numeric field**
- **Minimum 1**
- **Maximum 7 (with a CVM-R8D)**
- **Maximum 17 (with a CVM-R8D + CVM-R10)**

Number of relay outputs used in the CVM-R8D. Loads will be connected from output 2 to consecutive ones, i.e., in case of 3 loads, used outputs must be 2, 3 & 4.

HST ****

Hysteresis

- **Numeric field**
- **In % of allowable power demand**
- **Minimum 4%**
- **Maximum 50%**

Defines the area where no control action is taken, in % of allowable power demand.

R.T. ****

Delay at connection

- **Numeric parameter**
- **In minutes**
- **Maximum 999 min**

The minimum time between one load is turn off and turn on back. This time will be applied to all loads.

OFF.T****

Offset time in % of the window time.

It is defined as a percentage of the window time programmed, in which no operation will be made.

CIC.?

Linear or cyclic connection-disconnection mode.

- Options **YES** or **NO**.
- **YES** cyclic connection-disconnection mode
- **NO** linear connection-disconnection mode

When working in the cyclical mode, the controller will open the relay that has remained for the longest time closed, and will close the one for the longest time open.

When working in the linear mode, relays are open from lower to higher priority. Highest priority output is no 2.

CL.MD?

Clearing power demand records.

- Options **YES** or **NO**.
- With **YES** all power demand values recorded for tariffs 1, 2 & 3 are deleted.
- With **NO** no record is deleted.

When selecting **YES** all power demand values recorded for windows integrated from the last reset are deleted.

CE?

Change enable.

Options **YES** or **NO**.

- With **YES** possibility of setup modification is enabled.
- With **NO** no setup parameter can be modified.

To perform any modification of setup this option must be enabled selecting **YES**.

5.5.- DISPLAY MODE

The controller is in display mode when it is turn on or after exiting setup mode. Functions of keys in display mode is:



Accessing the setup menu.

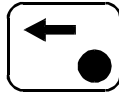

No function in display mode.

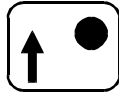

The next display parameter is shown when pressing this key.



Deletes the alarm whether this is activated.

Displayed parameters:

DEM ****

Power demand [kW].

Shows the average power demand during the programmed demand period. At the end of integration window time the power demand will correspond to the average power for the whole period.

Example:

**$P_{CON}=1000$ kW
Demand period 15 min**

200 kWh has been consumed after 7.5 min, the instrument will then show:

$$\mathbf{DEM = \frac{200kWh * 60min / h}{15min} = 800kW}$$

If no consumption would exist for the resting 7.5 min, the demand controller will shown 800kW on display at the end of the period.

MD1 ****

Maximum power demand for Tariff 1 [kW].

Maximum value recorded in an integration window during tariff 1.

MD2 ****

Maximum power demand for Tariff 2 [kW].

Maximum value recorded in an integration window during tariff 2.

MD3 ****

Maximum power demand for Tariff 3 [kW].

Maximum value recorded in an integration window during tariff 3.

01111111

Status of 8 first outputs.

Shows the status of the CVM-R8D outputs. Whether the relay is closed, a 1 is shown; whether it is open, a 0 is then shown. The first one correspond to the alarm relay, output 1, and the other ones to the loads.

9-11111

Status of 9 to 13 outputs.

Similar to above but for outputs 9 to 13. Only on display when the number of loads defined at the setup menu is higher than 8.

14-11111

Status of 14 to 18 outputs.

Similar to above but for outputs 14 to 18. Only on display when the number of loads defined at the setup menu is higher than 14.

TIM **.*

Lapsed time in minutes of the present window [min].

Time passed from the last synchronism pulse transmission. Whether the controller does not receive any synchronism pulse, this will switch to sliding window operation mode, and the figure 15 will be continuously shown on display.

6.- TECHNICAL FEATURES**Power Supply**

Voltage	Single phase 230 V a.c.
Voltage tolerance	+10 % / -15 %
Frequency	50 ... 60 Hz
Consumption	7 VA
Working temperature	0 to 50 ° C

Output relay features**(8 relays)**

Insulation voltage (Ui)	270 V a.c. / 125 V d.c.
Thermal current I _{th}	3 A
AC 11 I _e / U _e	2 A / 250 V a.c.
DC 11 I _e / U _e	2 A / 30 V d.c.
Maximum operation power	750 VA - 90 W
Mechanical life	2 x 10 ⁷ operations
Electrical life.....	1 x 10 ⁵ operations (full load)

Digital inputs	6 free voltage contacts (20 mA - 24 V d.c.)
-----------------------------	-------------------------------------------------

Analog inputs	Two 0 - 2 d.c. inputs
----------------------------	-----------------------

Constructive characteristics

Box type	Self-extinguishing, plastic, modular case
Connection terminals.....	Metallic terminals with "posidraft" screws
Assembly.....	Fitted onto symmetrical DIN 46277 (EN 50022) Possibility of screwing them down (4.2 mm Ø hole).

Frontal cover.....	Lexan
Protection degree.....	Built-in relay : IP 41 Terminals : IP 20
Dimensions	140 x 70 x 110 mm (8 module relay (As per DIN 43 880)

Safety conditions	Category II , as per EN 61010
--------------------------------	-------------------------------

Other CVM- R8 D features	- Alphanumerical display 1 x 8 characters (50 x 15 mm) - Four programmable keys .
---------------------------------------	-------------------------------------------------------------------------------------------

Relevant standards	IEC 255, IEC 348 , UNE 21 136 IEC 664, VDE 0110, UL 94
---------------------------------	-----------------------------------------------------------

Dimensions CVM-R8C & CVM-R8D :

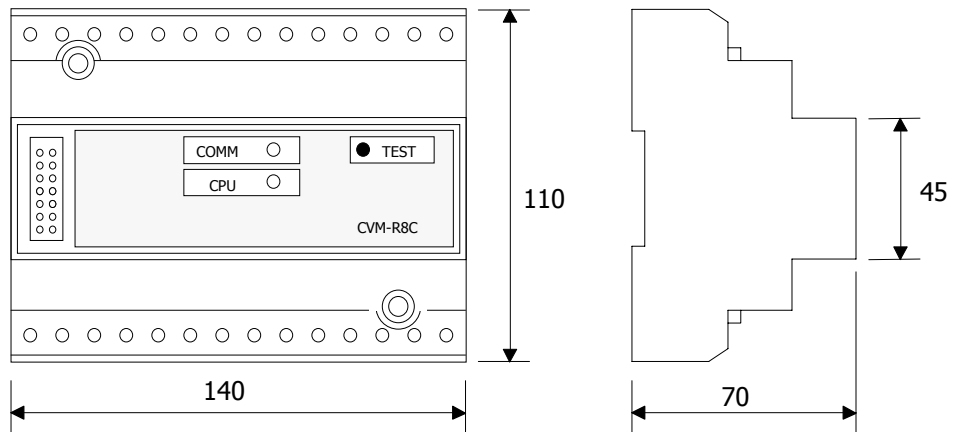

7.- SAFETY WARNINGS



All installation specification described at the previous chapters named INSTALLATION AND STARTUP and TECHNICAL FEATURES must be considered when operating with the instrument.

Note that with the instrument powered on, the terminals could be dangerous to touching and cover opening or elements removal actions may allow accessing dangerous parts. This instrument is designed and tested to meet IEC-348 standard and is factory-shipped at proper conditions .

8.- MAINTENANCE

The CVM-R8 does not require any special maintenance. No adjustment, maintenance or repairing action should be done over the instrument open and powered and, should those actions are essential, high-qualified operators must perform them.

Before any adjustment, replacement, maintenance or repairing operation is carried out, the instrument must be disconnected from any power supply source.

When any protection failure is suspected to exist, the instrument must be immediately put out of service. The own instrument design permits a quick replacement in case of damage.

9.- TECHNICAL SERVICE

For any inquiry about the instrument operation mode or in case of malfunction, you can contact CIRCUTOR S.A's technical service.

*CIRCUTOR S.A. – Aftersales Service
Lepanto, 49
08223 - TERRASSA (SPAIN)
Tel: 34 – 93 – 745 29 00
Fax: 34 – 93 – 745 29 14*