



SUPPLY NETWORK ANALYZER

CVM_k- HAR SERIES

INSTRUCTION MANUAL

(M 981 314/ 00A - Manual 1 / 2)

© CIRCUTOR S.A.

INDEX - CVMk-HAR USER'S GUIDE 1 / 2

Page N°

1.-	BASIC INSTRUCTIONS	2
1.1.-	Delivery spot check.....	2
1.2.-	Connection procedures.....	2
2.-	MAIN CHARACTERISTICS.....	3
2.1.-	Other Characteristics.....	4
3.-	INSTALLATION AND STARTUP.....	5
3.1.-	INSTALLATION.....	5
3.2.-	Connection terminal	8
3.3.-	Connection drawing for the CVMk-HAR - ITF (13 terminal model - ITF).....	9
4.-	OPERATION MODE.....	13
5.-	SETUP.....	17
5.1.-	Phase-Phase or Phase-Neutral voltages.....	17
5.2.-	Voltage Transformer Primary	18
5.3.-	Voltage Transformer Secondary	19
5.4.-	Current Transformer Primary.....	19
5.5.-	Harmonics SETUP	20
5.6.-	%THD (referred to RMS) or %d (referred to fundamental value)	20
5.7.-	DATE / TIME SETUP.....	21
6.-	SPECIFICATIONS	22
7.-	SAFETY CONSIDERATIONS	23
8.-	MAINTENANCE.....	23
9.-	TECHNICAL SERVICE.....	24

1.- BASIC INSTRUCTIONS

1.1.- Delivery spot check

This manual is issued to help all the CVMk-HAR users to install and use it in order get the best from it. After receiving the unit please check the following points:

- (a) Does this device corresponds to your order specifications?
- (b) Check if any damage was done during the shipment process.
- (c) Verify that it includes the following standard accessories:
 - *One connections terminal, *One instruction manual and *One set of labels

1.2.- Connection procedures



The manual you hold in your hands contains information and warnings about the CVMk-HAR that the user should respect in order to guarantee a proper operation of all the instrument functions and keep its safety conditions.

Before connecting the instrument to the mains verify the following:

(a) **Power supply : see rear part of your CVMk-HAR**

a.1.- **CVMk -HAR....** : Power supply Va.c. (Single phase) 50 ... 60 Hz

- Rated voltage: 230 V a.c. or 400 V a.c.
 240 V a.c. or 480 V a.c.
 110 V a.c.

a.2.- **CVMk-HAR... / SDC** : Power supply Vd.c.

- Rated voltage: 24 V d.c. (20 V d.c. 60 V d.c.)
 110 V d.c. (50 V d.c. 150 V d.c.)

(b) Maximum measuring voltage:

- 500 V a.c. phase-neutral / 866 V a.c. between phases
- CVMk-HAR for measurement at 110V: 100Va.c. phase-neutral /173Va.c. phase-phase*

(c) Maximum measuring current: Transformer of In / 5 A a.c.

2.- MAIN CHARACTERISTICS

The CVMk-HAR power meter is a programmable measuring instrument, offering several operation possibilities selectable in its SETUP option. Before power supplying the instrument, read the **CONNECTIONS** and **SETUP** sections and choose the most suitable operation mode for getting your desired data.

The CVMk-HAR is an instrument which measures, calculates and displays all the main electrical parameters at any electrical network (balanced or not). The measuring is true RMS value, through three a.c. Voltage inputs and three a.c. Current inputs (from Current Transformers .../ 5A).

By means of an internal microprocessor it simultaneously measures:

<i>parameter</i>	<i>L1</i>	<i>L2</i>	<i>L3</i>
Voltage (phase-neutral)	x	x	x
Voltage (phase-phase)	x	x	x
Current	x	x	x
% THD or % d of Voltage	x	x	x
% THD or % d of Current	x	x	x
Voltage harmonics up to the 50	x	x	x
Current harmonics up to the 50	x	x	x

The CVMk-HAR allows reading up to the 50th harmonic, shown in 3 big numerical displays, where you can see:

- (a) Phase-phase or phase-neutral voltage of the three phases
- (b) Current of the three phases
- (c) The THD of V of the three phases
- (d) The THD of I of the three phases

and 6 pages more : 6 harmonics can be selected in its SETUP option (up to 50th).

2.1.- Other Characteristics

- Panel mounting instrument of low dimensions (144 x 144 mm).
- True RMS measurements.
- Memorizes Maximum and Minimum values.
- Autoscaling during data reading.
- **Display : LCD or LEDs (check frontal cover)**

CVMk-HAR	Displays of liquid crystal, 4 digits (LCD), dimensions: 67 x 26 mm
CVMk-HAR- L	Displays of LEDs , 4 1/2 digits, green colour, dimensions: 60 x 20 mm

- Bubble keyboard, with 4 keys, for control and programming functions.
- 3 x 3 LED indicators (red, green and yellow) to know the parameter shown on display.
- Optional RS232 or RS485 communication modules.

3.- INSTALLATION AND STARTUP



The manual you hold in your hands contains information and warnings that the user should respect in order to guarantee a proper operation of all the instrument functions and keep its safety conditions.

The instrument must not be powered and used until its definitive assembly on the cabinet's door.

Whether the instrument is not used as manufacturer's specifications, the protection of the instrument can be damaged.

When any protection failure is suspected to exist (for example, it presents external visible damages), the instrument must be immediately powered off. In this case contact a qualified service representative.

3.1.- INSTALLATION

Before applying AC power to the, check following points :

a.- **Supply voltage : see rear part of your CVMk-HAR**

According CVMk-HAR model:

- a.1.- **CVMk-HAR** : - Power supply Vac (Single phase) 50 ...60 Hz
- 230 V a.c. or 400 V a.c.**
 - 240 V a.c. or 480 V a.c.**
 - 110 V c.a.**
- *Frequency* : 50 ... 60 Hz
- *Supply tolerance* : + 10 % / --15 %
- *Connection terminals* : Terminals 1 - 2 - 3 .
- *Instrument burden* : 3 VA

a.2.- **CVMk-HAR... / SDC** : - Power supply Vdc (only for LCD display version)

24 V d.c. (20 V d.c. 64 V d.c.)

110 V d.c. (64 V d.c. 130 V d.c.)

- *Connection terminals* : *Terminals 1 - 2 - 3 .*

- *Instrument burden* : *6 VA*

b.- Maximum voltage at the voltage measuring circuit:

Standard : **500 V a.c. phase-neutral / 866 V c.a. between phases**

A special model for 110 V measurement is also available:

100 V a.c. phase-neutral / 173 V a.c. between phases

c.- Maximum admissible current : Transformer of In / 5 A a.c.

d.- Operation conditions :

- Operating temperature : 0 to 50°C

- Humidity : 25 to 80 % R.H. noncondensing

e.- Safety : Designed to meet protection class II as per EN 61010.

Mounting: 

Instrument is to be mounted on panel (cutout $138^{+1} \times 138^{+1}$ mm, as per DIN 43 700). All connections keep inside the cabinet.

Note that with the instrument powered on, the terminals could be dangerous to touching and cover opening actions or elements removal may allow accessing dangerous parts. Therefore, the instrument must not be used until this is completely installed.

The instrument must be connected to a power supply circuit protected with gI type (IEC 269) or M type fuses rated between 0.5 and 2 A. This circuit should be provided with an automatic switch or any equivalent element to disconnect the instrument from the power supply network. The supply and measuring voltage circuits will be both connected through a wire with a minimum cross-section of 1 mm^2 .

The line of the current transformer secondary will have a minimum cross-section of $2,5 \text{ mm}^2$.

3.2.- Connection terminal

The **CVMk-HAR** has a connection terminal located at the side of the instrument to connect the power supply and the incoming network measuring signals.

This connection terminal consists of: **CVMk-HAR- ITF model** = 13 terminals

Termn. no.	Parameter
13	Neutral
12	VL1
11	VL2
10	VL3
9	S1 IL1
8	S2 IL1
7	S1 IL2
6	S2 IL2
5	S1 IL3
4	S2 IL3
Supply	

CVMk-HAR....-

A.C. Supply	
3 V
2 V
1	0 V

CVMk-HAR- / SDC

D.C. Supply	
3	
2	--
1	+d.c.

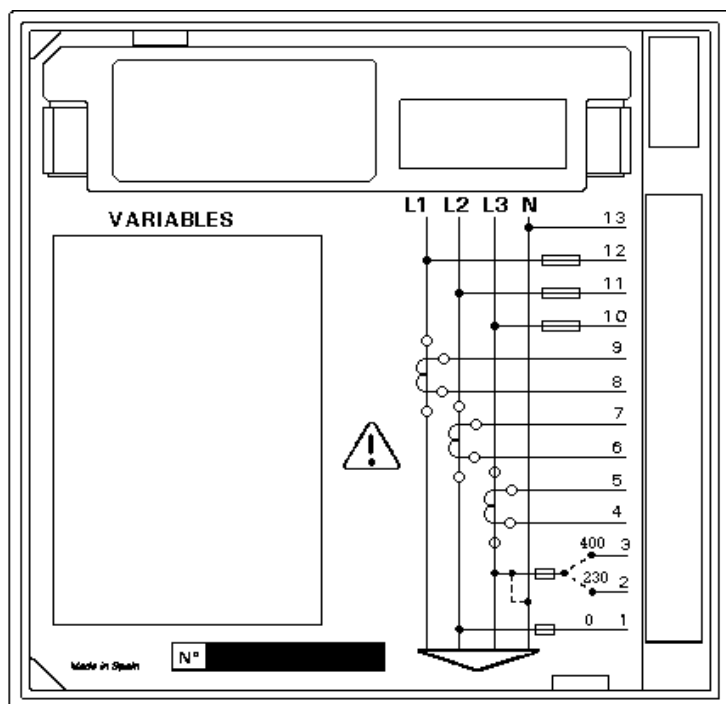

NOTE: Current inputs are isolated in the ... ITF ..1/5 A model

3.3.- Connection drawing for the CVMk-HAR - ITF (13 terminal model - ITF)

a) Connection diagram of the CVMk-HAR-ITF for a low voltage, three phase network:

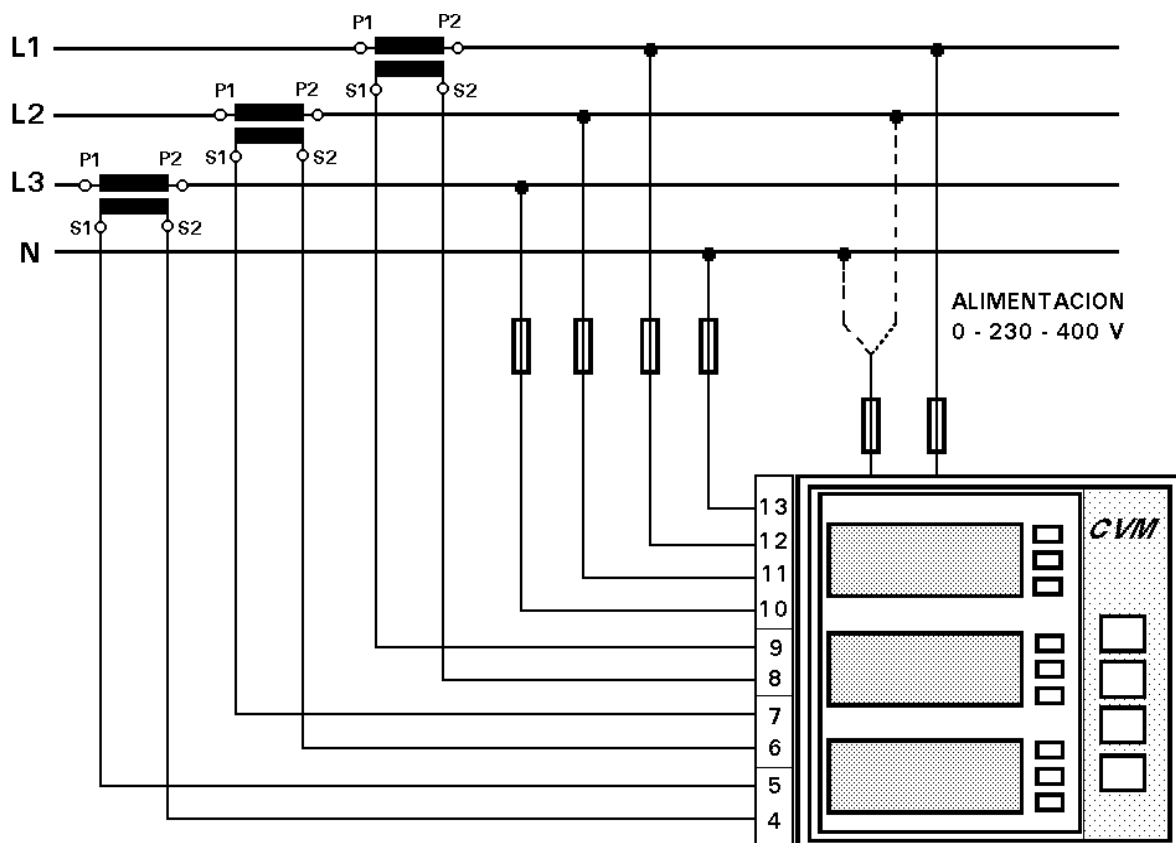

- Assure that L1, L2 and L3 phases coincide in voltage and current.
- Correct polarity? Reverse the current transformer placed at this phase.

b.- CVMk-HAR-ITF: 3 current transformers + two voltage transformer :

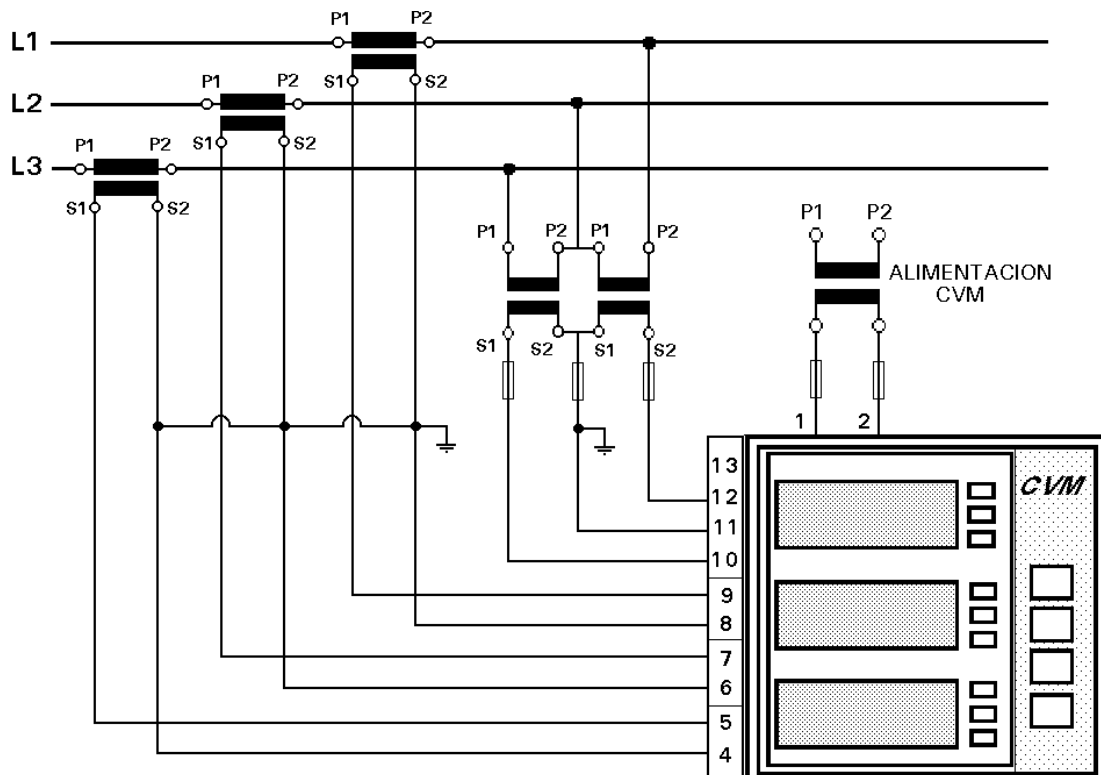

c.- **CVMk-HAR-ITF** : Two current transformers + 2 voltage transformers.

S2 of the current transformer grounded to earth

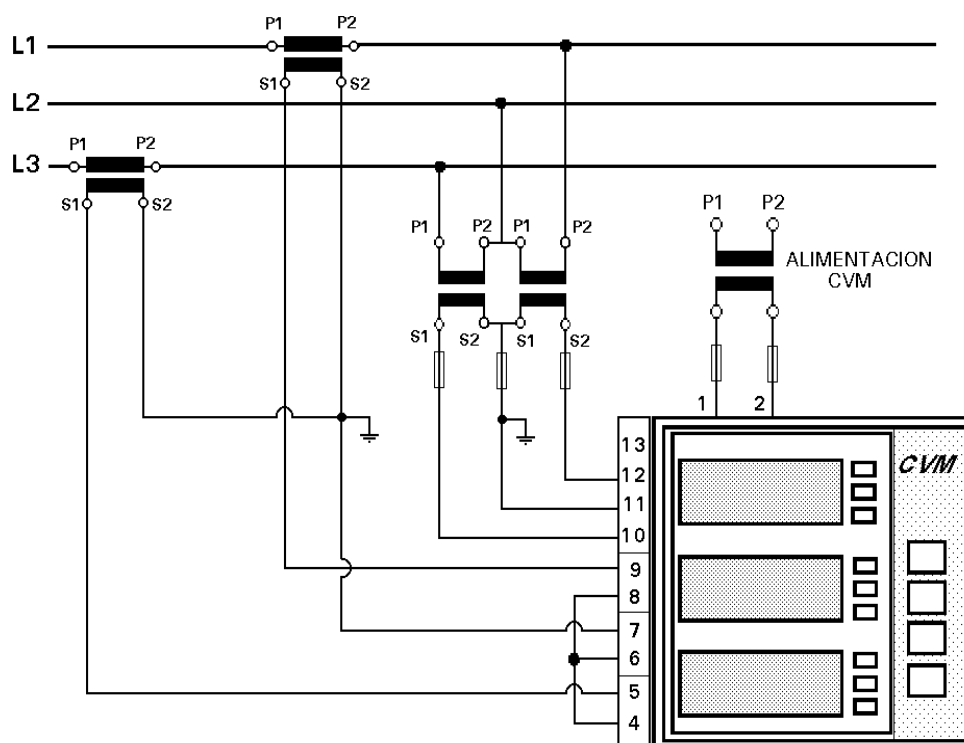

S1 of the current transformer grounded to earth

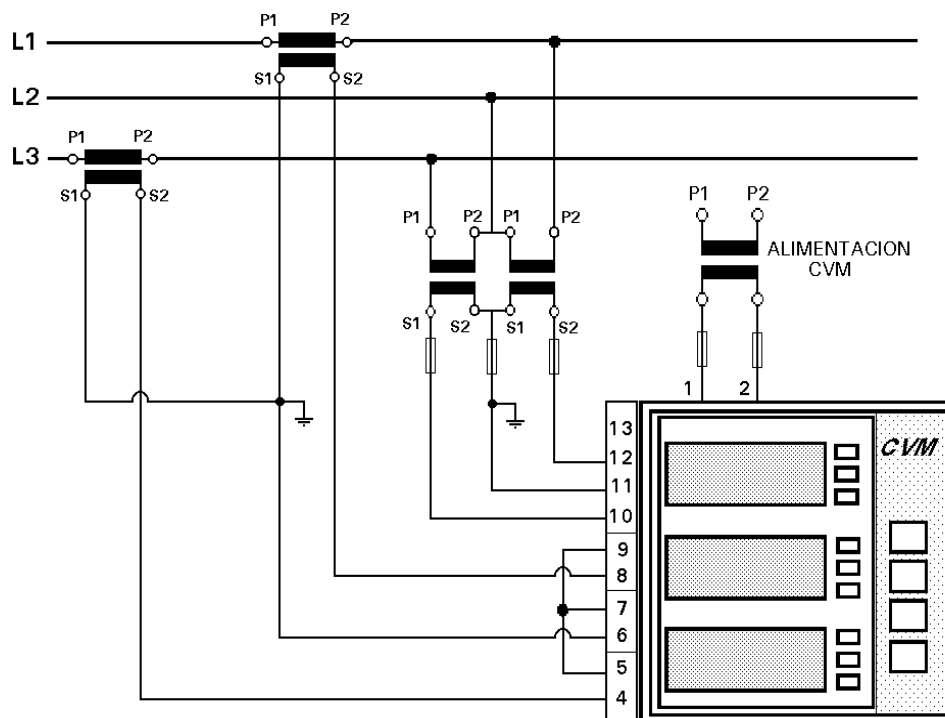

4.- OPERATION MODE

The instrument has three displays, and each one has three LED indicators (red, green and yellow). Every LED indicates the parameter presently shown by display.

When you switch on the power supply of the CVMk-HAR, all the 9 LED indicators will light on for some seconds, and you will see on the display: "Circutor **xxxx**" (program version) and following you will read "CARD TYPE xxxx" (identification of the connected module). After some seconds the instrument is ready to work, showing one of the three possible screens. One of the leds next to each display lights on indicating the parameter being measured.

display

When the first LED (red) of every display is lighting on, it means that we are reading VOLTAGE values. That is, the first display shows the voltage of phase L1 (V1), the second one the voltage of phase L2 (V2) and third one the voltage of phase L3 (V3).

If you press the "**display**" key, the three red LEDs will light off, and the three green LED will light on. It means that we are now reading the CURRENT values for each phase (A1, A2, A3).

Pressing again “**display**” red and yellow leds are simultaneously on to indicate that values of voltage THD are shown on display.

THD VL1 %	■ V 1	THD % of V phase L1
	A 1	
	■ HAR	
THD VL2 %	■ V 2	THD % of V phase L2
	A 2	
	■ HAR	
THD VL3 %	■ V 3	THD % of V phase L3
	A 3	
	■ HAR	

Pressing again “**display**” green and yellow leds are simultaneously on to indicate that values of current THD are shown on display.

THD AL1 %	V 1	THD % of A phase L1
	■ A 1	
	■ HAR	
THD AL2 %	V 2	THD % of A phase L2
	■ A 2	
	■ HAR	
THD AL3 %	V 3	THD % of A phase L3
	■ A 3	
	■ HAR	

- The %THD are referred to the fundamental value (d), or to the R.M.S. value (THD): You can see “THD” or “ d ” depending of the previous SET-UP.

All this pages are fixed.

Pressing again “display”, 6 additional screens can be user-configured:

 The SET-UP of the CVMk-HAR allows the selection of the harmonics that you want to see on the display (up to the 50th harmonic).

- When you see the harmonics page , the phases L1, L2 , L3 change to the next one automatically (rotary page) .

1h03	■ V 1	<u>phase (1,2 or 3) / harmonic no.</u> harmonic xx
	■ A 1	
	HAR	
Vxxx	■ V 2	Voltage V1-L1 (Volts)
	■ A 2	
	HAR	
Axxx	■ V 3	Current A1-L1 (Amps)
	■ A 3	
	HAR	

- Harmonics are given in %. The percentages of voltage and current harmonics are referred to the fundamental value.

max

Pressing the "**max**" key, the maximum values for the parameters being shown appear in the displays.

This function is only valid while you keep pressing the "**max**" key. If you stop pressing the key the instantaneous values appear again.

When showing maximum values the LED indicators remain blinking.

min

Pressing the "**min**" key, the minimum values for the parameters being shown appear in the displays.

This function is only valid while you keep pressing the "**min**" key. If you stop pressing the key the instantaneous values appear again.

When showing minimum values the LED indicators remain blinking.

Reset

Pressing the "**reset**" key the system is reset. This is equivalent to switch off the power supply of the instrument.

The stored maximum and minimum values will be automatically deleted from the internal memory.

If you are in the setup process and press the "**reset**" key, you exit it without saving any modification that you have done and making a reset of the system.

5.- SETUP

To access into the **setup menu** just follow these steps:

- (a) Connect (supply) the instrument.
- (b) Press the two green buttons (**max**, **min**) simultaneously.

You will see during a few seconds the word "**set**". It means that we are in the setup process. Then we go along the different options, step by step:

5.1.- Phase-Phase or Phase-Neutral voltages

After the word "**set**" you will see on the three displays the voltages of the phases L1, L2, L3.

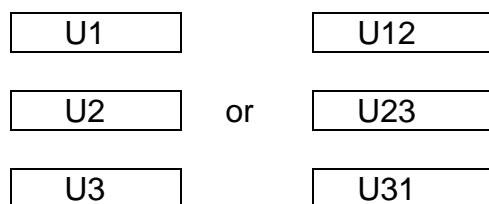

Phase to Neutral Voltages: U1 , U2 , U3

Phase to Phase Voltages : U12 , U23 , U31

a.- To select one of the voltage options just press the green key "**max**" and both options will appear alternately.

b.- When you get in the display the wished option just press the "**display**" key to validate it and access to the next setup option.

5.2.- Voltage Transformer Primary

On the screen we read the word "SET U P" followed by 6 digits. They allow us setting the primary of the voltage transformer.

SET U

P - - -

- - -

Last digit of the first display indicates "U" (Voltage) and first digit of the second display indicates "P" (Primary). It means that we can set the primary of the voltage transformer. To avoid mistakes the Voltage red LEDs remain lit on.

a.- To write or modify the value just repeatedly press the "**max**" key and the blinking digit value will be increased.

b.- When the value on screen is the proper one, we can pass to the next digit by pressing the "**min**" key in order to modify the other values.

c.- When the blinking digit is the last one, pressing the "**min**" key we go back to the initial value: set values can be again modified.

d.- Press "**display**" to pass to the next setup option.

5.3.- Voltage Transformer Secondary

We can now set the value of the secondary of the voltage transformer. Only three digits are available:

SET U
S
- - -

Same process than in point 5.2.-:

- "**max**" key: Allows us modifying the value of the blinking digit. Each time it is pressed the value is increased.
- "**min**" key: Allows us the validation of the blinking digit and going to the next one.
- Press "**display**" to pass to the next setup option.

If the CVMk-HAR is directly connected to the mains (without voltage transformer) the values of primary and secondary must be the same, for instance 000001/001.

5.4.- Current Transformer Primary

"SET A P" and five digits appear on screen allowing us to set the primary of the current transformer. The current green LEDs light on to avoid mistakes.

SET A
P - -
- - -

The procedure is the same one done at the previous sections with the "**max**", "**min**" and "**display**" keys.

NOTES:

- The maximum programmable value is 10.000
- The secondary of the current transformers is not programmable. It is automatically taken as 5 A (... / 5 A ac)

5.5.- Harmonics SETUP

This option allows to program until 6 harmonics that you can see on the display (01 to 50) . You can program 3 of the desired harmonics in this first page :

XX
XX
XX

and 3 more in the next page :

XX
XX
XX

5.6.- %THD (referred to RMS) or %d (referred to fundamental value)

This option allows selecting among **THD** or **d** option. (The "**max**" key allows modifying the selected option).

SEL
thd

OTHER SETUP SCREENS WITH THE CONNECTION OF THE ENERGY AND CLOCK MODULES

5.7.- DATE / TIME SETUP



Pressing the "**display**" key we will see in the CVMk-HAR.. screen the following:

- 1.- DAY : MONTH ("SET day dd:mm")
- 2.- YEAR ("SET YEAR xxxx ") 4 digits
- 3.- HOURS : MINUTES ("SET HOUR hh:mm")

For their setup:

- "**max**" key: Allows modifying the value of the blinking digit.
- "**min**" key: Allows the validation of the blinking digits and go to the next one.
- To pass to the next option press "**display**".

If you don't want to modify the time, just press three times "**display**" without making any modification.

6.- SPECIFICATIONS

Power supply : see specifications on the rear part of the CVMk-HAR

- **CVMk-HAR...** : Single phase 230 V a.c. or 400 V a.c.
240 V a.c. or 480 V a.c.
110 V a.c.

Voltage tolerance: +10 % / -15 %

Frequency: 50 ... 60 Hz

- **CVMk-HAR... / SDC** : 24 V d.c. or 110 V d.c.

Power consumption 3 VA

Operation temperature 0 to 50° C

Measuring Circuits :

Rated voltage 500 V a.c. Phase - Neutral / 866 V a.c. between phases

Other voltagesWith Voltage Transformers

Rated currentIn / 5 A (**isolated input in the ITF model**)

Permanent overload1.2 In

Current input power0.6 VA

Accuracy :

Voltage 0.5 % of readout ± 2 digits

Current 0.5 % of readout ± 2 digits

Test conditions :

- Errors due to Voltage T. and Current T. are not included

- Temperature between + 5 °C and + 45 °C

- Measured values between 5 % ... 100 %

- Security Category II , EN-61010

Standards : IEC 664, VDE 0110, UL 94 , IEC 801 , IEC 348 , IEC 571-1
EN 50081-1, EN-61010-1 , EN 50082-1

Mechanical Characteristics :

Installation	Panel mounting
Connection	Fixed connection terminal
Protection	IP-41
Dimensions	144 x 144 mm (DIN 43 700)
Weight	0.75 kg

7.- SAFETY CONSIDERATIONS



All installation specification described at the previous chapters named INSTALLATION AND STARTUP, INSTALLATION MODES and SPECIFICATIONS.

Note that with the instrument powered on, the terminals could be dangerous to touching and cover opening actions or elements removal may allow accessing dangerous parts. This instrument is factory-shipped at proper operation condition.

8.- MAINTENANCE

The CVMk-HAR does not require any special maintenance. No adjustment, maintenance or repairing action should be done over the instrument open and powered and, should those actions are essential, high-qualified operators must perform them.

Before any adjustment, replacement, maintenance or repairing operation is carried out, the instrument must be disconnected from any power supply source.

When any protection failure is suspected to exist, the instrument must be immediately put out of service. The instrument's design allow a quick replacement in case of any failure.

9.- TECHNICAL SERVICE

For any inquiry about the instrument performance or whether any failure happens, contact to CIRCUTOR's technical service.

CIRCUTOR S.A. - Aftersales Service
c / Lepanto , 49
08223 - TERRASSA - SPAIN
Tel - 34 - 93 -745 29 00
fax- 34 - 93 -745 29 14

E_Mail: central@circutor.es



SUPPLY NETWORK ANALYZER

CVM_k-HAR SERIES

INSTRUCTION MANUAL

(M 981 314 / 99 B - Manual 2 / 2)

(c) CIRCUTOR S.A.

INDEX - CVMk-HAR USER'S GUIDE 2 / 2

	page
10.- MODULES :.....	2
11.- ADDITIONAL SCREEN WITH THE <u>RELAY OUTPUT</u> MODULES.....	3
11.1.- Relay modules: <i>CVM-ERC-2</i> or <i>CVM-RED-C2</i> (2 outputs).	3
12.- Module connection procedure	4
12.1.- DB-9 type connector: <i>CVM-ERC-2</i> (2 relays).....	4
12.1.1.- Connection with RS-485 communication modules.	4
12.1.2.- Connections: <i>CVM-RED-C2</i> Module (Communication + 2 relay outputs)	5
12.1.3.- Other modules.	5
13.- CVMk-HAR COMMUNICATIONS	6
13.1.- DEMAND FORMAT.....	6
13.2.- COMMANDS	6
13.2.1.- COMMANDS FOR THE PARAMETER READING.....	7
13.2.2.- COMMAND for reading harmonic parameters from the CVMk-HAR	8
13.2.3.- COMMAND to read all the CVMk-HAR parameters.....	8
13.2.4.- PROGRAMMING COMMANDS	9
13.2.5.- CVMk-HAR COMMANDS WITH THE ENERGY + CLOCK MODULE	10
13.2.6.- COMMANDS FOR THE CONFIGURATION OF THE RELAY MODULES.....	10
13.3.- EXAMPLES.....	11
13.4.- DEFAULT CVMk-HAR CONFIGURATION : 00 / 9.600 / 7 bits / N / 1 bit.....	12
A.- Second SET-UP of the CVMk-HAR.....	14
A.1.- COMMUNICATION PROTOCOL SETUP mode	14
A.2.- Power units setup	15
13.5.- Communication parameters setup	15
B.- MODBUS © protocol.....	16

10.- MODULES :

Modules are cards to be inserted into the rear part of the CVMk-HAR in order to expand its standard features. Available modules are following listed:

Code	Type	Description	Version
7 70 191	<i>CVM / 485</i>	RS-485 Module	card 3
7 70 192	<i>CVM / 232</i>	RS-232 Module	card 0
7 70 193	<i>CVM / ER-485</i>	RS-485 + energy Module	card 5
7 70 194	<i>CVM / ER-232</i>	RS-232 + energy Module	card 4
7 70 199	<i>CVM / ERC-2</i>	Energy + 2 output relays	card 202
7 70 207	<i>CVM / RED- C2</i>	RED + 2 outputs	card 242

Expansion modules provide more parameters to be displayed (additional SETUP).

Note: Other modules might be used with the CVMk-HAR, but some features might be disabled. The performance of such modules will be the same that for the ER or ER-485 modules.

11.- ADDITIONAL SCREEN WITH THE RELAY OUTPUT MODULES

11.1.- Relay modules: *CVM-ERC-2* or *CVM-RED-C2* (2 outputs).

You can set for each output:

② MAXIMUM value of %THD or %d
④ Delay for the condition

Following screens are successively displayed by the CVMk-HAR when this setup option is reached (provided the pertinent module is inserted into the analyzer):

a.- **ALARM conditions for Voltage Harmonic Distortion** (Relay 1)

These alarm conditions are to be set at the following screen:

Thd V or d V	Setting alarm conditions for the Voltage Harmonic Distortion
000.0	☞ Maximum value
000	☞ Delay is seconds

b.- **ALARM conditions for Current Harmonic Distortion** (Relay 2)

These alarm conditions are to be set at the following screen:

Thd A or d A	Setting alarm conditions for the Current Harmonic Distortion
000.0	☞ Maximum value
000	☞ Delay is seconds

Pressing again "**display**" the setup is exited.

ALARM ACTIVATION: Alarms will be activated when the value of THD at any phase exceeds the set value.

The **DELAY** set value is applied either to the connection or the disconnection when alarm conditions occur.

12.- Module connection procedure

12.1.- DB-9 type connector: *CVM-ERC-2* (2 relays)

	Terminal	Signal		Terminal	Signal
RELAY 1	6	Relay 1 common	RELAY 2	9	Relay 2 common
	2	NO		5	NO
	1	NC		4	NC

- Maximum voltage between terminals = 100 V a.c.

12.1.1.- Connection with RS-485 communication modules.

For all modules equipped with RS-485 communication outputs, only communication to PC is enabled. That way, RED type modules does not allow communication with other peripherals.

DB-9 connection lay out is:

1 ① ----- TX --
 2 ② ----- TX +
 5 ⑤ ----- GND

12.1.2.- Connections: CVM-RED-C2 Module (Communication + 2 relay outputs)

For all modules equipped with RS-485 communication outputs, only communication to PC is enabled. That way, RED type modules does not allow communication with other peripherals.

This module is identical to the CVM/ER-485 module, but delivering two free-voltage contact outputs (Card type 0242).

- **DB- 9 OUTPUT: equivalent to a CVM/ER-485 type module.**

- **COMBICON type TERMINAL CONNECTION (4 terminals): Module with 2 static outputs**

- static contacts through OPTOMOS element (120 mA - 300 V peak).

①	Output 1
②	
③	Output 2
④	

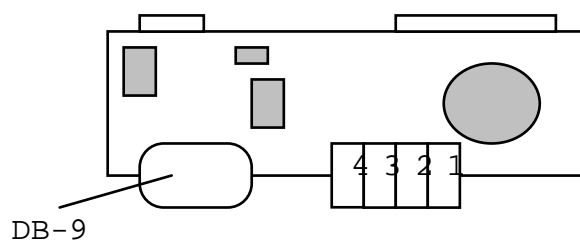

12.1.3.- Other modules.

Other modules might be used with the CVMk-HAR, but some features might be disabled

For instance:

- CVM/RED, CVM/RED-C420, CVM/RED-420 & CVM/REDMAX: operation of these modules are similar to the CVM/ER485.
- CVM/ERC-1, CVM/ER420-1, CVM/ER420-2 & CVM/ERC-1-420: operation of these modules are similar to the CVM/ER.

13.- CVMk-HAR COMMUNICATIONS

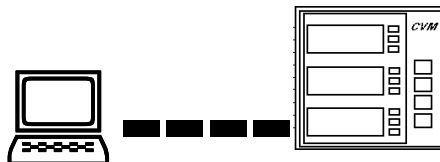

One or some CVMk-HAR... can be connected to a PC. With this system we can get all the parameters in one central point of reading. The CVMk-HAR..., with the CVM/xx485 module, has a serial output type RS-485. If we connect more than one CVMk-HAR... to the same communication line, we have to assign to each of them a different code or direction (from 01 to 99), since the PC needs the identification of every measuring point. The CVMk-HAR... can also work with a serial output type RS-232, with the use of a CVM/xx232 module.

PROTOCOL: Question / Answer

13.1.- DEMAND FORMAT

The demand format is: **\$PPCCAA.... ch [LF]** (example = **\$00RVI75**)

The answer format is : **\$PPAA.... ch [LF]**

\$	Any message starts with this symbol
PP	CVMk-HAR code or direction (00 a 99) (decimal- ASCII)
CCC	COMMAND
AA	ARGUMENT: Only with the writing commands Wxx (decimal-ASCII)
Ch	CHECK-SUM : Check-sum of all the elements forming the message. It is calculated with the decimal addition of all the previous bytes in ASCII and translating the result to hexadecimal. Two digits are taken. <u>example</u> = \$00RVI --> 36 + 48 + 48 + 82 + 86 + 73 = 373 373 decimal \equiv 175 hexad. CHECK-SUM = 75 ----> \$00RVI75 [LF]
[LF]	LINE FEED indicates the end of the message. (chr\$(10))

13.2.- COMMANDS

13.2.1.- COMMANDS FOR THE PARAMETER READING

COM-MAND	CONCEPT	QUESTION	ANSWER	UNITS
RVI	Read V ph.-neutral INST	\$ PP RVI ch	\$ PP 4 x 9 digits ch	V
RVM	Read V ph.-neutral MAX	\$ PP RVM ch	\$ PP 3 x 9 digits ch	V
RVm	Read V ph.-neutral MIN	\$ PP RVm ch	\$ PP 3 x 9 digits ch	V
ROI	Read V phase-ph. INST	\$ PP ROI ch	\$ PP 4 x 9 digits ch	V
ROM	Read V.phase-ph. MAX	\$ PP ROM ch	\$ PP 3 x 9 digits ch	V
ROm	Read V.phase-ph. MIN	\$ PP ROm ch	\$ PP 3 x 9 digits ch	V
RAI	Read Current INST	\$ PP RAI ch	\$ PP 4 x 9 digits ch	mA
RAM	Read Current MAX	\$ PP RAM ch	\$ PP 3 x 9 digits ch	mA
RAm	Read Current MIN	\$ PP RAm ch	\$ PP 3 x 9 digits ch	mA
RHI	Read Frequency INST	\$ PP RHI ch	\$ PP 1x 3 digits ch	Hz x 10
RHM	Read Frequency MAX	\$ PP RHM ch	\$ PP 1x 3 digits ch	Hz x 10
RHm	Read Frequency MIN	\$ PP RHm ch	\$ PP 1x 3 digits ch	Hz x 10
THD	Read distortion	\$pp THD ch	\$pp (3 x 4dig.) Thd V +(3 x 4 dig.) Thd I ch	% * 10
THM	Read maximum distortion	\$pp THM ch	\$pp (3 x 4dig.) Thd V +(3 x 4 dig.) Thd I ch	% * 10
THm	Read minimum distortion	\$pp THm ch	\$pp (3 x 4dig.) Thd V +(3 x 4 dig.) Thd I ch	% * 10

13.2.2.- COMMAND for reading harmonic parameters from the CVMk-HAR

COM-MAND	CONCEPT	QUESTION	ANSWER
RAR	Read harmonics	\$pp RAR XYZZWW	\$pp+16 Fundamental +n*8harmonics + ch

Question:

- X : Choice even or odd harmonics (E/O)
- Y : Phase choice (1/2/3)
- ZZ : Choice of first harmonic no.
- WW : Total number of harmonics.

Answer:

- 16 Fundamental = 8 Voltage fundamental + 8 Current fundamental
- n * 8 harmonics = (4 Voltage distortion + 4 Current distortion) demanded harmonics

13.2.3.- COMMAND to read all the CVMk-HAR parameters

COMMAND	CONCEPT	QUESTION	ANSWER SIZE
RAL	Read TOTAL	\$pp RAL ch	\$pp + 76 bytes + ch

With this parameter all the parameters are requested: 9 x 8 bytes in hexa-ASCII format in the following order:

[0] L12	[1] L23	[2] L31	[3] Av	Voltage phase-phase
[4] L1	[5] L2	[6] L3	[7] Av	Voltage phase-neutral
[8] L1	[9] L2	[10] L3	[11] Av	Current
<ul style="list-style-type: none"> - 2 bytes : current units 00 - mA / 01 - A - 2 bytes : not used 				

13.2.4.- PROGRAMMING COMMANDS

COM-MAND	CONCEPT	QUESTION	ANSWER
RRT	Read transforming ratios (prim V, sec V, prim A)	\$pp RRT ch	\$pp 14 digits ch (6 + 3 + 5)
WRT	Write transforming ratios	\$pp 14 digits ch (6 + 3 + 5)	\$PP ACK ch
RRS	Read communications (*)	\$pp RRS ch	\$pp 13 digits ch
WRS	Write communications (*)	\$pp 13 digits ch	\$PP ACK ch
RMA	Read harmonic configuration	\$pp RMA ch	\$pp 1 Thd or D (0/1)
WMA	Write harmonic configuration	\$pp WMA 1Thd o D(0/1)	\$pp ACK ch
RCP	Read configuration Page 2 + Page3 + initial page	\$pp RCP ch	\$pp 13 digits ch (6 x 2 + 1 initial)
WCP	Write configuration. Page	\$pp 13 digits ch	\$PP ACK ch
RMM	Read type of set voltage (single / compound)	\$pp RMM ch	\$PP 1 digit ch 1=S / 0 =C
WMM	Write measuring mode (single / compound)	\$pp 1 digit ch 1=single / 0 = comp	\$PP ACK ch
VER	Read CVMk-HAR version	\$pp VER ch	\$PP 4 digits ch
TAR	Read type of card (module) + scale kW- MW (Lo - Hi)	\$pp TAR ch	\$PP 5 digits ch (4 card + 1 scale)
DEF	Write default parameters	\$pp DEF ch	\$PP ACK ch
INI	Reset	\$pp INI ch	-----

(*) NOTE : The RRS / WRS command (communications):

- 2 digits peripheral number / 1 digit Parity / 1 digit length / 1 digit Stop bits/
- 4 digits Baud rate SERIAL output / 4 digit Baud rate 2nd output (only for "RED" module: 2nd RS-485 output).

13.2.5.- CVMk-HAR COMMANDS WITH THE ENERGY + CLOCK MODULE

COM..	CONCEPT	QUESTION	ANSWER	UNIT
RCL	Read date and time dd/mm/yy hh:mm:ss	\$pp RCL ch	\$pp 17 characters ch	
WCL	Write value for the clock dd/mm/yyyy hh:mm:ss	\$pp 19 charac. ch (10 + space +8)	\$pp ACK ch	

13.2.6.- COMMANDS FOR THE CONFIGURATION OF THE RELAY MODULES

RCO	Read alarm configuration	\$pp RCO ch	\$pp + 4 Alarm1 condition+ 3 Alarm1 Delay + 4 Alarm2 condition+ 3 Alarm2 Delay	
WCO	Write alarm configuration	\$pp WCO + 4 Alarm1 condition+ 3 Alarm1 Delay + 4 Alarm2 condition+ 3 Alarm2 Delay		\$pp ACK ch
OUT	Alarms status	\$pp OUT	\$pp Alarm1 status+ Alarm2 status (0-Off, 1-Onn)	

13.3.- EXAMPLES

<p>SEND : \$00RVI75 [LF] RECEIVED : \$0000000021900000012100000010300000014865 [LF]</p> <p>\$00, V1 = 000000219 = 219 V V2 = 000000121 = 121 V V3 = 000000103 = 103 V Vavg = 000000148 = 148 V</p>
<p>SEND : \$00RRT7C [LF] (V / A ratio) RECEIVED : \$000250001100050032 [LF]</p> <p>\$00, Voltage primary = 025000 = 25.000 (6 digits). Voltage secondary = 110 = 110 (3 digits). Current primary = 00500 = 500 (5 digits).</p>
<p>SEND : \$00RRS7B [LF] (Communication) RECEIVED: \$00000719600480017 [LF]</p> <p>\$00, Peripheral number = 00 Parity = 0 = Non (1 dig.) Bits = 7 (1 dig.) Stop bits = 1 (1 dig.) Baud rate = 9600 (4 dig.) (COM1) 2nd Baud rate = 4800 (4 dig.) (COM2 - RED module)</p>
<p>SEND : \$00RAI60 [LF] RECEIVED : \$0000021400000019000000018500000019600073 [LF]</p> <p>\$00, A1= 000214000 = 214000 mA = 214 A A2= 000190000 = 190000 mA = 190 A A3= 000185000 = 185000 mA = 185 A Am =000196000 = 196000 mA = 196 A</p>

13.4.- DEFAULT CVMk-HAR CONFIGURATION : 00 / 9.600 / 7 bits / N / 1 bit

- Available baud rates: 2.400 - 4.800 - 9.600 - 19.200 bauds

- **CVM / RS-485 module: DB-9 - Male connector**

No. pin Signal

1	①	-----	TX	--
2	②	-----	TX	+
5	⑤	-----	GND	

- **CVM/ RS-232 module: RS-232 cable (CVMk-HAR ----- PC - DB-9)**

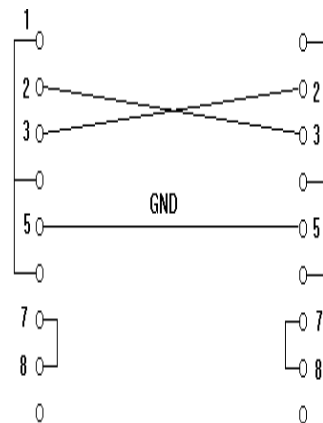

- RS-485 COMMUNICATION LINK TO MULTIPLE DEVICES

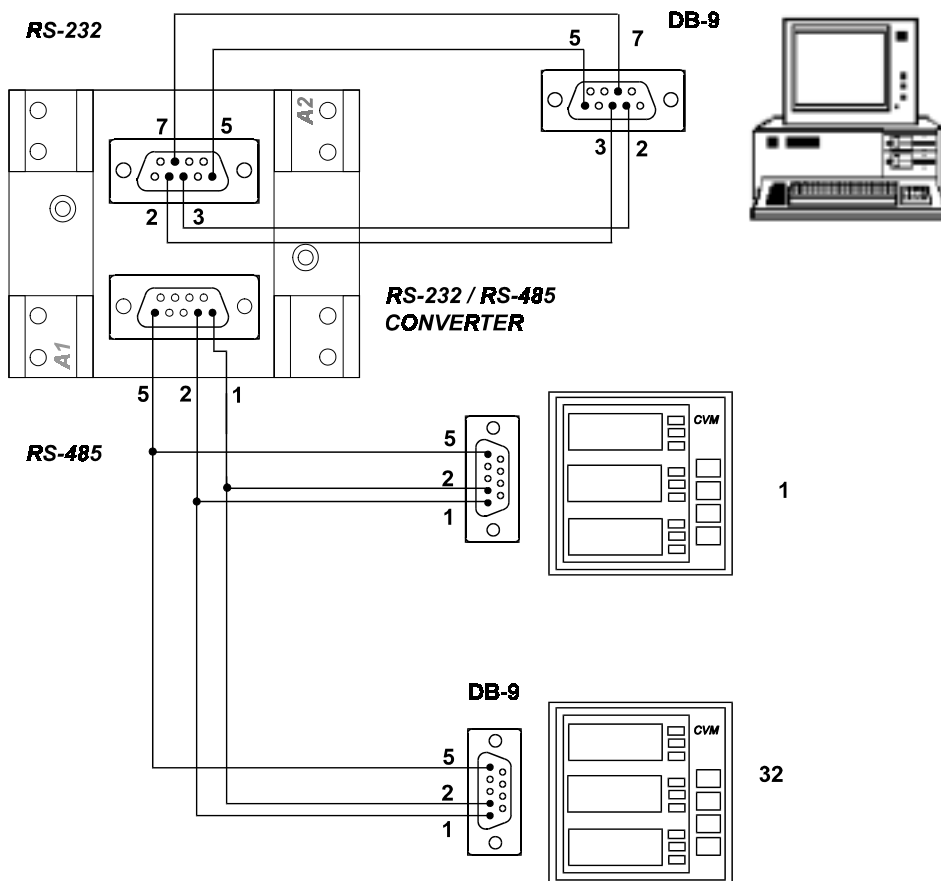

☑ RS-485 connection will be carried out by means of a **twisted and screened cable**, with a minimum of 3 wires, with a maximum distance between the CVMk-HAR and the last peripheral of 1.200 m. The CVMk-HAR with the CVM/xxx485 module uses a RS-485 communication bus allowing up to a **maximum of 32 devices in parallel (Multidot bus) per used port of the PC.**

A.- Second SET-UP of the CVMk-HAR

It is possible to access to a second MENU of SET-UP that allows the configuration of the CVMk-HAR with other options different of the standard ones.

To enter into it proceed as follows:

- Without power supply in the CVMk-HAR, press simultaneously "**display**", "**max**" and "**min**" keys.
- Keeping these keys pressed, supply the CVMk-HAR.

We will read on the CVMk-HAR screen the following:

A.1.- COMMUNICATION PROTOCOL SETUP mode

SET	
PROT	Protocol:
CIRC	 CIRCUTOR (CIRC) or MODBUS (c) (BUS) protocol

The "**max**" key allows the modification of this option.

(*) To work with MODBUS see the **APPENDIX B.-**

- "**display**" key: allows validating the selected option and pass to the next setup screen:

A.2.- Power units setup

SET

ESCA

power scale:

LO

☞ Selection of **kW** (LO) or **MW** (HI)

This option is not used for the CVMk-HAR since no power nor energy is measured.

- "**display**" key: allows validating the selected option and passing to the next setup screen:

13.5.- Communication parameters setup

SET

Cdef

default configuration

NO

☞ "**max**" key allows choosing NO / YES

- If YES is chosen: the configuration is **00 / 9.600 / 7 bits / N / 1 bit**
- If NO is chosen, pressing "**display**" following options successively appear:
 - n PER : Peripheral No.
 - Baud 1 : baud rate
 - Parity : No, even, odd
 - LEN : (length) 7 or 8
 - Stop bits : 1 or 2
 - Baud 2 : not used

B.- MODBUS © protocol

The CVMk-HAR power meter has also the **MODBUS ©** protocol .

When the CVMk-HAR is configured to work with MODBUS protocol , it use the **RTU mode** (Remote terminal Unit).

The format for each byte in RTU mode is :

- * *Code* : **8-bit binary** , hexadecimal 0-9, A-F
Two hexadecimal characters contained in each 8-bit field of the message .
- * *Bits per Byte* : 8 data bits
- * *Error Check Field* : Cyclical Redundancy Check (**CRC**) .

MODBUS FUNCTIONS :

FUNCTION 3 or 4 Reads the n Words (16 bits- 2 bytes). It uses this function to read all the electrical parameters of the CVMk-HAR. This registers are longs of 32 bits ; In this case It is necessary to read two Words. (4 bytes - XX XX XX XX).

FUNCTION 6 Writing of 1 Word. This function is used to change from MODBUS to CIRBUS.

Valid Register 0
Valid value 0

Registers of the CVMk-HAR electrical parameters :

<i>VARIABLE</i>	<i>REGISTERS</i>		<i>FORMAT</i>
	<i>DECIMAL</i>	<i>HEXA-DECIMAL</i>	
V 1	0 - 1	00 - 01	V
V 2	2 - 3	02 - 03	V
V 3	4 - 5	04 - 05	V
mA 1	6 - 7	06 - 07	mA
mA 2	8 - 9	08 - 09	mA
mA 3	10 - 11	0A - 0B	mA
THD V 1	12 - 13	0C - 0D	(%) * 10
THD V 2	14 - 15	0E - 0F	(%) * 10
THD V 3	16 - 17	10 - 11	(%) * 10
THD A 1	18 - 19	12 - 13	(%) * 10
THD A 2	20 - 21	14 - 15	(%) * 10
THD A 3	22 - 23	16 - 17	(%) * 10
Hz (x10)	24 - 25	18 - 19	(Hz) * 10
V 12	26 - 27	1A - 1B	V
V 13	28 - 29	1C - 1D	V
V 23	30 - 31	1E - 1F	V
A 1	32 - 33	20 - 21	A
A 2	34 - 35	22 - 23	A
A 3	36 - 37	24 - 25	A

Registers assigned to harmonics:

Harmonic	L1		L2		L3	
	Voltage	Current	Voltage	Current	Voltage	Current
Fundamental	0100	0101	0102	0103	0104	0105
2	0106	0107	0108	0109	010A	010B
3	010C	010D	010E	010F	0110	0111
4	0112	0113	0114	0115	0116	0117
5	0118	0119	011A	011B	011C	011D
6	011E	011F	0120	0121	0122	0123
7	0124	0125	0126	0127	0128	0129
8	012A	012B	012C	012D	012E	012F
9	0130	0131	0132	0133	0134	0135
10	0136	0137	0138	0139	013A	013B
11	013C	013D	013E	013F	0140	0141
12	0142	0143	0144	0145	0146	0147
13	0148	0149	014A	014B	014C	014D
14	014E	014F	0150	0151	0152	0153
15	0154	0155	0156	0157	0158	0159
16	015A	015B	015C	015D	015E	015F
17	0160	0161	0162	0163	0164	0165
18	0166	0167	0168	0169	016A	016B
19	016C	016D	016E	016F	0170	0171
20	0172	0173	0174	0175	0176	0177
21	0178	0179	017A	017B	017C	017D
22	017E	017F	0180	0181	0182	0183
23	0184	0185	0186	0187	0188	0189
24	018A	018B	018C	018D	018E	018F
25	0190	0191	0192	0193	0194	0195

Harmonic	L1		L2		L3	
	Voltage	Current	Voltage	Current	Voltage	Current
26	0196	0197	0198	0199	019A	019B
27	019C	019D	019E	019F	01A0	01A1
28	01A2	01A3	01A4	01A5	01A6	01A7
29	01A8	01A9	01AA	01AB	01AC	01AD
30	01AE	01AF	01B0	01B1	02B2	02B3
31	01B4	01B5	01B6	01B7	01B8	01B9
32	01BA	01BB	01BC	01BD	01BE	01BF
33	01C0	01C1	01C2	01C3	01C4	01C5
34	01C6	01C7	01C8	01C9	01CA	01CB
35	01CC	01CD	01CE	01CF	01D0	01D1
36	01D2	01D3	01D4	01D5	01D6	01D7
37	01D8	01D9	01DA	01DB	01DC	01DD
38	01DE	01DF	01E0	01E1	02E2	02E3
39	01E4	01E5	01E6	01E7	01E8	01E9
40	01EA	01EB	01EC	01ED	01EE	01EF
41	01F0	01F1	01F2	01F3	01F4	01F5
42	01F6	01F7	01F8	01F9	01FA	01FB
43	01FC	01FD	01FE	01FF	0200	0201
44	0202	0203	0204	0205	0206	0207
45	0208	0209	020A	020B	020C	020D
46	020E	020F	0210	0211	0212	0213
47	0214	0215	0216	0217	0218	0219
48	021A	021B	021C	021D	021E	021F
49	0220	0221	0222	0223	0224	0225
50	0226	0227	0228	0229	022A	022B

Note: Harmonic distortion is given as % * 10.

Update of harmonic distortion parameters

The CVMk-HAR does not update values of harmonic distortion registers until the update instruction is received. That way, we can assure that all distortion values read refer to the same signal.

Update instruction: PP0600000001CCCC
PP Peripheral No.
06 Writing function
0000 Writing of 1 Words
0001 Writing register 1
CCCC CRC

EXAMPLE

QUERY

0A 03 00 26 00 10 C4 B3

0A	CVMk-HAR number, 10 in decimal
03	Reading function
00 00	Starting address (first register)
00 06	Number of registers for reading
C4B3	CRC character

RESPONSE

0A 03 0C 00 00 00 EF 00 00 00 EE 00 00 00 EF 38 18

0A	CVMk-HAR number, 10 in decimal
03	Reading function (03 or 04).
0C	Data response bytes
00 00 00 EF	Phase 1 voltage with a decimal value of 239 V
00 00 00 EE	Phase 2 voltage with a decimal value of 238 V
00 00 0F EF	Phase 3 voltage with a decimal value of 239 V
38 18	CRC character

MODBUS SELECTION

There are two ways for the change of the protocol (CIRBUS or MODBUS) :

a.- It is possible to access to a second MENU of SET-UP that allows the configuration of the CVMk-HAR : CIRBUS or MODBUS

(*) see the **APPENDIX A.-**.

b.- With instructions via RS.

b.1.- When the device is on CIRBUS , for changing to MODBUS via RS, it is done sending the command **MBS**.

CIRBUS -> MODBUS	\$PP MBS ch (Lf)	ASCII
PP	Peripheral number (CVMk-HAR)	
MBS	Instruction to change from CIRBUS to MODBUS	
ch	CHECK SUM	

b.2.- When the device is on MODBUS , for changing to CIRBUS via RS, it is necessary to use the **FUNCTION 6** (Writing of 1 Word) .

MODBUS -> CIRBUS	PP 06 00010000CCCC	BINARY
PP	Peripheral number (CVMk-HAR)	
06	Writing function (Only to change).	
0000	Writing of 1 Word	
0000	Writing register : 0	
CCCC	CRC	