



ELECTRICAL NETWORK ANALYZER

AR5

(Code 7 71 301)

**(Program for energy meter check)
(CHECK-METER)**

(Code 7 71 326)

INSTRUCTION MANUAL

(M 981 503 / 99 B)

© CIRCUTOR S.A.

CONTENTS	page
1.- DESCRIPTION	3
2.- CHECKING THE CONTENTS OF YOUR PACKAGE.....	3
3.- ANALYZER STARTUP	4
3.1.- Loading a new program.....	4
3.2.- Choice of the operation mode program	5
4.- INSTALLATION AND STARTUP	5
4.1.- Starting the AR5 analyzer up.....	6
5.- CONNECTION MODES	7
6.- DATA VISUALIZATION ON DISPLAY	9
6.1.- Screen of instantaneous values	9
6.2.- Screen for energy meter check.	10
6.3.- Warning messages.....	10
7.- PROGRAMMING THE AR5.....	12
7.1.- Set-up of Instantaneous Values	12
7.1.1.- SET-UP menu	13
7.1.1.1.- MEASURE Menu.....	14
7.1.1.1.1. <i>CIRCUIT: Circuit type</i>	14
7.1.1.1.2. <i>TR.REL : Transforming ratios</i>	14
7.1.1.1.3. <i>TR.CAL : Calibration ratios</i>	15
7.1.1.2.- COMM: Communication parameters	15
7.1.1.3.- CLOCK: Internal clock	15
7.1.1.4.- RECALL: Read Configuration	16
7.1.2.- DISPLAY Menu.....	16
7.1.3.- FILES menu.	16
7.1.3.1.- DIR: Directory.....	17
7.1.3.2.- DELETE: Deleting a file.....	17
7.1.3.3.- FORMAT: Formatting the AR5 internal memory	17
7.1.4.- Clear menu.	17
7.2.- Setup for energy meter check	18
8.- Operation mode	19
8.1.- Checking mechanic energy meters	20
8.2.- Checking electronic energy meters.....	21
9.- TECHNICAL SPECIFICATIONS	22
10.- SAFETY WARNINGS.....	23
11.- TECHNICAL SERVICE.....	23
A.- QUICK GUIDE - SETUP.	24
B.- QUICK GUIDE FOR AR5 - CHECK-METER.	24

1.- DESCRIPTION

This manual is aimed to familiarize the user with the operation of the portable analyzer model AR5 when working with the “Check-meter program”.

To get all necessary information about operation instructions and safety warnings of the portable analyzer AR5 consult its instruction manual (code M981501).

The AR5 analyzer loaded with the “check-meter” program permits to check both electronic or mechanic energy meters, either for active and reactive energy totalization. The Check-Meter instrument delivers an appropriate checking mode for each energy meter type.

Besides of checking energy meter utility, the analyzer provides the visualization on screen of several electrical parameters to verify the correct connection of the analyzer. These two functions of the Check-Meter cannot be simultaneously done at the same time.

Recorded data can be downloaded from the AR5 to a PC and further analyzed by means of the PC software.

Recording data process is done by means of an liner memory. That means that once memory is full, no new data is recorded anymore.

2.- CHECKING THE CONTENTS OF YOUR PACKAGE

After receiving the analyzer, please check the following points:

- a) The delivered material corresponds with your order specifications.
- b) After unpacking, check that the instrument has not been damaged in transit.
- c) The standard set includes the following items:
 - 1 cartridge for programming the AR5 containing the ordered operation mode program.
 - 1 Instruction Manual.
 - 3,5” diskettes containing the PC software update.

3.- ANALYZER STARTUP

3.1.- Loading a new program

The AR5 has an internal memory to save diverse operation mode programs to be used by the user.

Before initiating this procedure, check that the AR5 battery is charged. Loading program action cannot be done whether the power supplier set is connected to the AR5, since the cartridge is to be connected to the input also used to connect the power supplier set.

To load any program, follow these instructions precisely:

- Turn the meter off.
- Connect the cartridge to the *AUX* input of the meter.
- Turn the meter on.
- Select with the keys [**▲**] & [**▼**] that you want to perform a program loading action (LOAD PROGRAM). Press [**ENTER**] or wait for a while to confirm this operation.
- Select the position to save the program into.
- The AR5 will perform a test to check that the cartridge has been properly connected.
- If an inserted cartridge is detected, then the program will be loaded.
- Once the loading is completed, reset the meter.
- If no cartridge was found or a loading mistake occurred, reset the meter and redo the above steps.

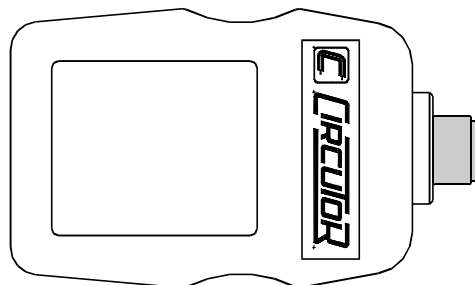

**A cartridge will be only valid for the analyzer which the program was for the first time loaded into.
Note on the cartridge the serial number of its related AR5.**

3.2.- Choice of the operation mode program

The AR5 can hold in memory different operation mode programs. The choice of the program to be used is done when starting the meter up.

- Turn the AR5 on.
- A list of available programs will be shown on display.
- Use keys [▲] & [▼] for the choice of the desired program.
- Press [ENTER] or wait for a while to confirm this operation.

CHECK THE SET-UP UP !!!!

All programs have an independent set-up, therefore, the set-up must be always check to ensure a proper operation.

For instance, whether the set-up is modified at the “ANALYZER” program, these modification will not be valid for the “CHECK-METER” program, and so for any program.

4.- INSTALLATION AND STARTUP



The manual you hold in your hands contains information and warnings that the user should respect in order to guarantee a proper operation of all the instrument functions and keep its safety conditions.

Whether the instrument is not used according to manufacturer’s specifications, the protection of the instrument can be damaged. Note that with the instrument powered on, cover opening or elements removal actions may allow accessing dangerous parts. Therefore, before any adjustment, replacement, maintenance or repairing operation is carried out, the instrument must be disconnected from any power supply source.

When any protection failure is suspected to exist, the instrument must be immediately put out of service. Contact then with a qualified service representative.

4.1.- Starting the AR5 analyzer up

Before connecting the instrument to the mains, please consider following points:

- 1) Supply voltage: 230 V a.c. +15 % / -15 %, 50... 60 Hz.

The instrument must be energized by a supply circuit with protection earth terminal.

- 2) Maximum input voltage at the voltage measuring circuit:
500 V a.c. phase-neutral
866 V a.c. between phases

Use always the voltage leads factory-shipped with the instrument.

- 3) Burden: 8 VA.
- 4) Operation conditions:
 - Operation temperature: 0° to 50°C.
 - Operation humidity: 25 % to 75 % RH.
- 5) Safety : Designed to meet protection class II as per EN 61010.
- 6) Current measuring range: according to the ammeter clamp used

To start measurement works with the analyzer:

- 7) Connect to the main 230 V a.c./ 12 V d.c., Code. 7 71 351, with the factory-shipped cables. Also connect the protection earth terminal to avoid possible disturbances over the analyzer.
- 8) Connect the voltage leads at each phase of the monitored system, as well as the neutral whether it exists.
- 9) Connect the ammeter clamps at each phase conductor. Each current phase must coincide with its voltage phase.
- 10) Respect the connection modes shown at each diagram to correctly achieve energy readouts.

5.- CONNECTION MODES

A.- THREE-PHASE MODE CONNECTION DIAGRAM

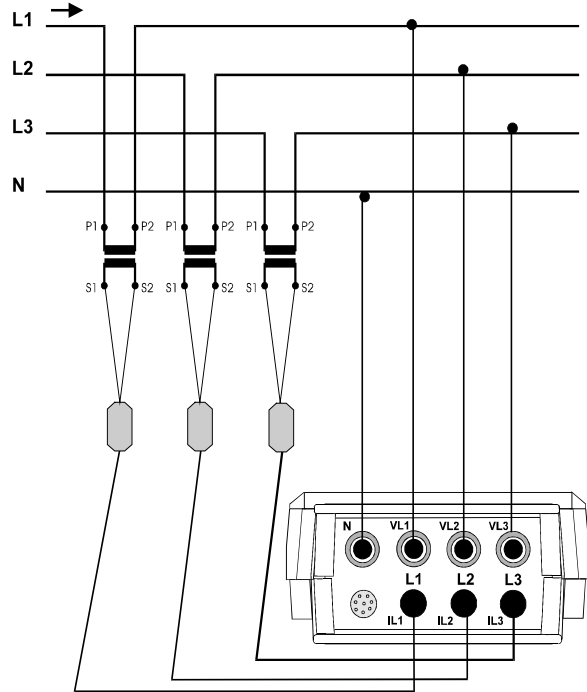
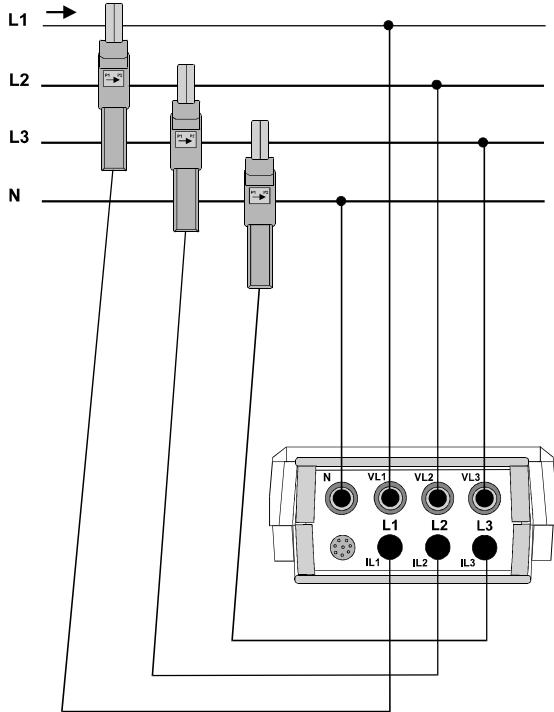

B.- SINGLE-PHASE MODE CONNECTION DIAGRAM

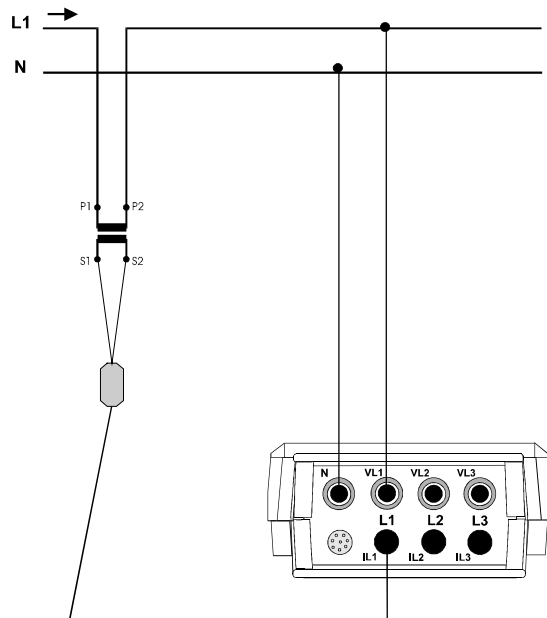
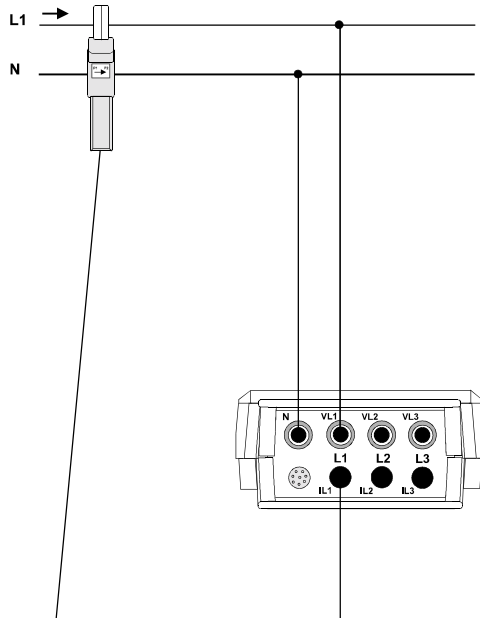

C.- ARON MODE CONNECTION DIAGRAM

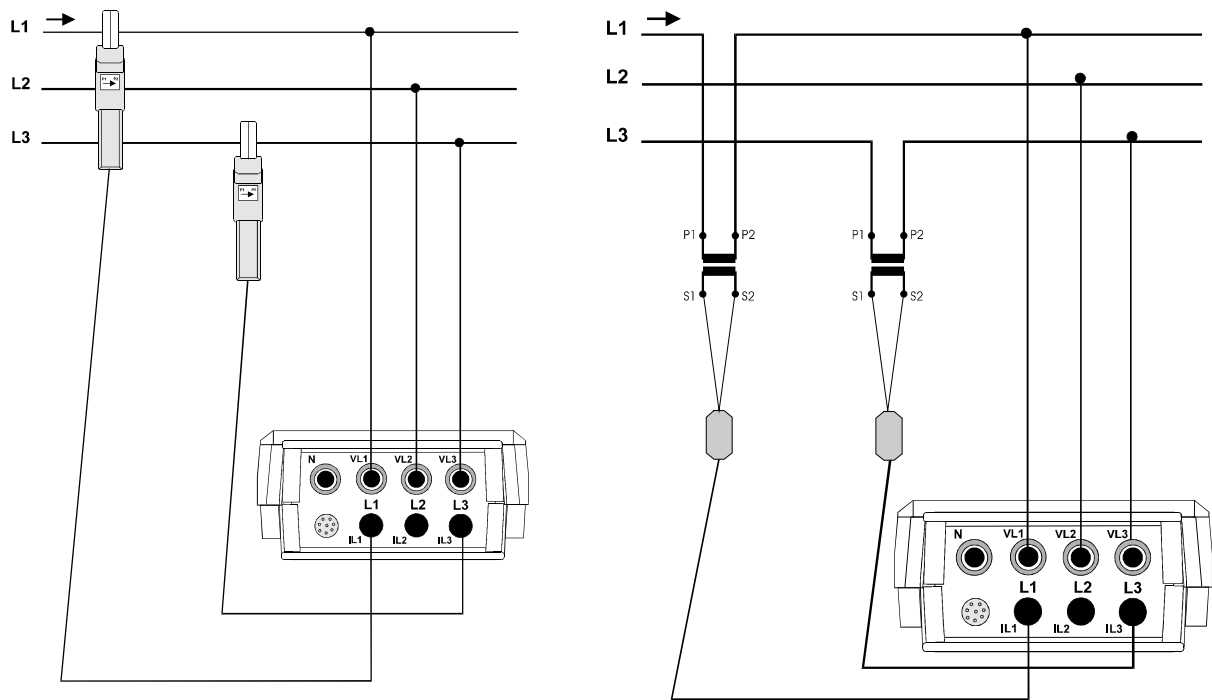

6.- DATA VISUALIZATION ON DISPLAY

All measured instantaneous values on the screen for energy meter check can be read on a 160 x 160 pixel, liquid, crystal display.

Use the key **[ESC]** to switch the visualization screen.

6.1.- Screen of instantaneous values

This screen is only for the verification of a correct connection of the analyzer. So, you can verify the correct positioning of the ammeter clamps, the transforming ration setting, concord of voltage and current phases

Energy values are partial values. The value is always reset to zero when accessing this screen. These values are not accumulated.

Pressing the key **[SET]** from this screen the set-up menu is accessed.

When powering the AR5 on, the display will show:

AR5 CHECK-METER				
INST	L1	L2	L3	III
Vp-n	220	221	223	221
A				
kW				
kvarL				
kvar				
C				
P.F.				
Hz				
kVA				
kWh			0.000	
kvarhL			0.000	
kvarhC			0.000	
25 / 10 / 97 17 : 31 : 29				

Verification screen

Voltage : Readout of the instantaneous RMS value measured at each phase (L1, L2 & L3) and the average value of the instantaneous values of the three phases (III).

Current : Readout of the instantaneous RMS value measured at each phase (L1, L2 & L3) and the average value of the instantaneous values of the three phases (III).

Active power: The active power is calculated from instantaneous voltage and current data. The readout gives the instantaneous values of the active power of each phase and also the three phase total instantaneous active power, which is the addition of each phase value.

Inductive reactive power: The inductive reactive power is calculated from instantaneous voltage and current data. The readout gives the instantaneous values of the inductive reactive power of each phase and also the three phase total instantaneous inductive reactive power, which is the addition of each phase value.

Capacitive reactive power: The capacitive reactive power is calculated from instantaneous voltage and current data. The readout gives the instantaneous values of the capacitive reactive power of each phase and also the three phase total instantaneous capacitive reactive power, which is the addition of each phase value.

Power factor : Readout of the power factor of each phase and the three phase average value.

Frequency : Readout of the instantaneous value of the frequency (Hz).

Apparent power : Readout of the three phase total instantaneous apparent, which is the addition of each phase value.

Energies: Readout of the instantaneous value of the active, inductive reactive and capacitive inductive energy accumulated. These are always reset to zero when this screen is exited.

Time and Date. (time/date): Readout of present time and date. For any modification, see section 7.1.1.3.-.

6.2.- Screen for energy meter check.

This screen delivers the tools to perform the energy meter check. By means of keys [**^**] & [**v**] the position of the screen to be modified is selected. This position is enabled to be modified when pressing the key [**SET**].

AR5 CHECK-METER	
User Name	
1 / 1	5 / 5A
?	kWh
?	TURNS I I I Ph .
?	nTURNS?
?	kWh START
?	kWh END
RECORD	
?	Wh METER
?	Wh AR5
- - . - %	

AR5 CHECK-METER	
User's data	
Voltage ratio setting Current ratio setting	
Mechanic energy meter	kW/turn ratio of the energy meter Energy meter type (Active/Reactive)
	No. of turns of the check
Electronic energy meter	Initial energy of the energy meter Final energy of the energy meter
	Save check
Measurement of the energy meter	
Measurement of the AR5	
Energy meter error	

6.3.- Warning messages

Some warning messages can appear on the visualization screens. These messages inform about the AR5 performance:

- **STOP:** The analyzer is recording no data.
- **TRIG?:** Trigger conditions are not met. No data is being recorded.
- **M. Full:** Memory is full.
- **M.Error:** There is an error in the memory. The memory must be formatted.
-  Analyzer's battery status. Notice that when only one bar is shown, the analyzer's battery is very low and this can be powered off at any moment.
- **WARNING MAX 500 V:** The maximum allowable phase to neutral voltage of 500 V has been exceeded during the measuring process. When measuring phase to phase voltages the limit is set at 866 V.

When the energy meter checking process is finished, following messages might be shown on screen:

- **Overflow Energy:** The checking process has been too long. The check process duration can last a maximum of 20 hour at full-load conditions.
- **999%:** The error of the checked energy meter in comparison with the value measured by the CHECK-METER is very big.

7.- PROGRAMMING THE AR5

The “CHECK-METER” program has 2 different set-up menus:

- AR5 Set-up. This is accessible from the screen of instantaneous values (Section 7.1.-)
- Check Set-up. This is accessible from the screen of energy meter check (Section 7.2.-).

7.1.- Set-up of Instantaneous Values

To access AR5 set-up options press the key **[SET]**. The analyzer will then inquiry for a password that consists of a key sequence to be pressed (the user has 15 seconds to press this sequence):

PASSWORD
[◀] [SET] [▲] [SET]

Once the password is pressed, the analyzer will inquire for a confirmation before stopping the disturbance capture process and permitting the modification of set-up parameters.

Configuration parameters are independent for each program, that is, a modification over a certain program will not be applied over other programs.

Diverse setting MENUS are available:

SETUP
CONTRAST
RUN
FILES

➡ INITIAL MENU

- Select one option with keys **[▼]** & **[▲]**.
- To access any menu option use **[▶]** or **[ENTER]**.
- To close the menu press **[◀]** or **[ESC]**. If this key is used when only the main menu is open, this is closed. Whether any modification over any set-up parameter was done, before closing a confirmation of set-up change is requested on display.

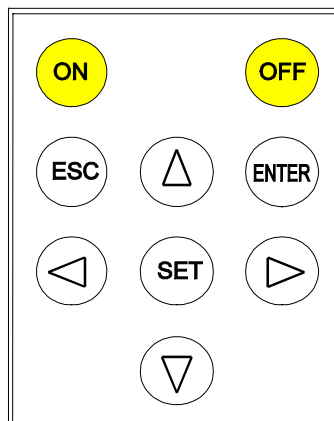

7.1.1.- SET-UP menu

The **AR5** meter can be user-configured to different performances involving its data analysis and recording modes, as it is followed shown:

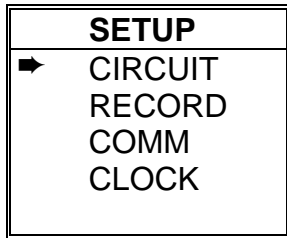

☞ SET-UP menu.

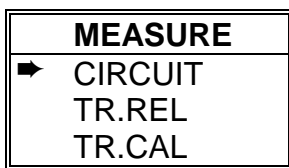

Three-phase, single-phase, ARON.
Transforming ratio for V & A.
Calibration ratio



Baud / Parity / Bits / Stop bits.



DD/MM/YY hh:mm:ss.



Standard
Recall Stand.. sure <yes > <no>.

7.1.1.1.- MEASURE Menu

Measuring conditions are set at this option: **Setting the connection type and P.T. and C.T. transforming ratios.**

MEASURE :	
▶	CIRCUIT
	TR.REL
	TR.CAL

Three-phase, Single-phase or, ARON
Prim. V, Secun. V, Prim. A
Calibration ratio

7.1.1.1.1. CIRCUIT: Circuit type

The CHECK-METER can be used for the verification of three-phase, ARON or single-phase energy meters (rotary input). Select here the desired choice.

7.1.1.1.2. TR.REL : Transforming ratios

Set here transforming ratios for voltage and current inputs.

TR.REL :	
▶	REL. V
	REL. A

Primary and secondary voltage values
Primary current value

- REL. V: Voltage transformer ratio. The primary voltage is firstly asked, and then the secondary voltage.
- REL. A: Ammeter clamp primary. *The secondary is always set at 2 V~ (it is not user-programmable).*

NOTE 1 : REL. V --> *This option permits to program:*

- a) *If voltage is directly measured (no voltage transformer is used), you must set PRIM.V = 1 / SECV.V = 1*
- b) *Whether the energy meter is being checking from the checking terminal, the same transforming ratio of the checked energy meter must be then set.*

NOTE 2 : REL. A --> *This option permits to program:*

- a) *The ratio of the ammeter clamp to be used.*
- b) *Whether the energy meter is being checking from the checking terminal, then the CP-5 type ammeter clamp must be used. For this case, the C.T. primary must be set at the same transforming ratio of the checked energy meter.*

The ratio set must be checked every time that the ammeter clamp is changed or a new energy meter is going to be checked.

7.1.1.1.3. TR.CAL : Calibration ratios

One of the accessories of the AR5 to be used with the “Check-Meter” program are the verification clamps. Every clamp is delivered with a calibration factor indicated on the label.

This factor depends on each clamp, therefore, each factor must be entered for each current phase. The set calibration factor must coincide with the calibration factor of the clamp placed in the accordant phase.

7.1.1.2.- COMM: Communication parameters

Program here the parameters of the built-in RS-232 serial output. When selecting this option the present parameters are shown on display:

COMM
9600 NO 8 1

Baud / Parity / Length / Stop bits

- Pressing **[ENTER]**: values on display are directly validated.
- **To modify:** (rotary input).
- Select with keys **[▶]** or **[◀]** the position to modify.
- Though keys **[▼]**, **[▲]** the value of the selected position is increased or decreased.
- **[ENTER]** to validate the total value or **[ESC]** to exit with no modification.

7.1.1.3.- CLOCK: Internal clock

Set here the AR5 internal clock: date / time. When selecting this option the present values are shown on display:

CLOCK
00 /00 /00 00 :00 : 00

day/month/year hour/minute/second

Proceed as for the previous section.

7.1.1.4.- RECALL: Read Configuration

You can here recall a **standard** configuration.

```
RECALL STAND..  
sure? <yes > <no>
```

- A confirmation is requested: "Recall Setup sure <yes> or <no>". With keys [▶] & [◀] select yes or no, and then press [ENTER].

A "**Standard**" operation program for the AR5 is available to be user-recalled. Its features are:

- C.T. Ratio (SET + A) : 5
- V.T. Ratio (SET + V) : 1 / 1
- Circuit type : Three phase (III - Phase)
- File name (FILE Name) : CK_METER
- FILE type : .ACM
- Communication parameters : 9600,No,8,1

7.1.2.- DISPLAY Menu

The user can here vary the contrast of the AR5 display:

- With the [▶] you can intensify the display contrast and with the key [◀] this can be lowered:

```
CONTRAST  
██████████
```

LOW ◀ ▶ HIGH %

7.1.3.- FILES menu.

The non-volatile AR5 internal memory is storing data up to its maximum capacity. Once full, neither new data will not be saved in, nor stored data will be lost (provided no incorrect operation is done).

When memory is full, the display will show: "**MEMORY FULL**".

```
FILES  
▶ DIR  
DELETE  
FORMAT
```

☞ FILES MENU

7.1.3.1.- DIR: Directory.

This option shows on display a directory of all files saved in memory.

```

  AR5 - DIR
CK_METER. ACM xxxxx bytes  ↵ File name / File size
  dd / mm / yy  hh : mm : ss          Day / Time
TEST1. A5T          xxxxx bytes
  dd / mm / yy  hh : mm : ss
STD-PROG. A5X      xxxxx bytes
  dd / mm / yy  hh : mm : ss

..... / .....
```

Free bytes: xxxxxxxxxx ↵ *Number of free bytes in memory*

- Keys [▼] or [▲] allows reading more files in case that all files stored by the AR5 cannot be shown in only one screen.
- Keys [ENTER] or [ESC] to exit.

7.1.3.2.- DELETE: Deleting a file

You can here delete any file from the internal memory.

```

  AR5 – DELETE
STD-PROG. ACM      xxxxx bytes  ↵ File name / File size
TEST1. A5T         xxxxx bytes
STD-PROG. A5T     xxxxx bytes
.....
```

- With keys [▼] & [▲] select the file to be deleted.
- [ENTER] to confirm selected file erasing. Once press, a confirmation is required.
- Press key [ESC] to exit with no modification.

7.1.3.3.- FORMAT: Formatting the AR5 internal memory

This option lets the user to format the internal memory. A confirmation is required to perform this action. Take into account that this action will mean all stored data to be deleted.

Note: Do not turn the AR5 off during the memory format process, otherwise the display will show an error message and the process should be redone.

7.1.4.- Clear menu.

This option lets the user to reset energy counters to zero at the screen of instantaneous values.

Note: Values of energy meters are also always reset to zero when the analyzer is powered on, or when the screen for energy meter check is accessed from the screen of instantaneous values.

7.2.- Setup for energy meter check

AR5 CHECK-METER			
User Name			(1) User's data
1/1V	5/5A		(2) P.T. and C.T. ratios
?	kWh		(3) Check of energy meters
?	TURNS III-ph.		
?	nTURNS?		(4) Check of mechanic energy meters
?	kWh START		(5) Check of electronic energy meters
?	kWh END		
RECORD			(6) Saving check results
?	Wh	METER	(7) Check result
?	Wh	AR5	
<div style="text-align: center;"> - - - %  </div>			(8) % Error

- Use the keys [**▼**] & [**▲**] to select the option to be modified.
- Press the key [**SET**], to modify the selected option.
- Press the key [**ENTER**] to start the energy meter checking process.
- Press the key [**ESC**] to switch to the screen of instantaneous values.

According the position within the verification screen, by pressing [**SET**] you can define:

1. Type the name of the user, no. of contract and a brief commentary about the performed checking action.
2. Measurement conditions setting:
 - Primary and Secondary of the P.T. used.
 - Primary of the C.T.
3. Features of the meter to be checked and type of connection:
 - Energy meter type:
 - kWh -> Checking of active energy meters.
 - kvarh -> Checking of reactive energy meters.
 - kWh / no. of turns ratio of the mechanic energy meter. When checking an electronic energy meter, this section is not considered.
 - Circuit type: select the connection type used for the energy meter check: ARON, three-phase (III-Phase) or single-phase (II-Phase).
4. Mechanic energy meter check: set the number of turns for the mechanic energy meter checking. When checking an electronic energy meter, this section is not considered.
5. Electronic energy meter check: set the value of the energy meter when starting the check and also when this is finished..
6. RECORD: To save in memory the record of the performed check.
7. This section will show the real value measured by the AR5 and also the value that the CHECK-METER should have measured according to the user-programmed values (points: 3, 4 & 5).
8. Error: You can here read the % of error for the energy meter check in relation with the measurement performed by the AR5.
9. To save the check results (6)

8.- Operation mode

When checking energy meters it is advisable to:

- **For any type of energy meter:** To perform the energy meter check when the installation is at full operation conditions. The higher the consumption is, the higher the check reliability will be.
- **For active energy meters:** Whether power factor correction units are installed in the power system, check that those are in operation. The higher the power factor is, the higher the check reliability will be.. It is advisable to perform the checking process with a power factor $>0,71$.
- **For reactive energy meters:** Whether power factor correction units are installed in the power system, check that those are disconnected. in operation. The lower the power factor is, the lower the check reliability will be.. It is advisable to perform the checking process with a power factor $<0,71$.

When the check process is finished, following messages could be shown on screen:

- **Overflow Energy:** The checking process has been too long. The AR5's inner energy counter cannot count up to such a high energy level. The check process duration can last a maximum of 20 hour at full-load conditions.
- **999%:** The error of the checked energy meter in comparison with the value measured by the CHECK-METER is very big.

**Check of active energy meters:
Connect all power factor correction systems**

**Check of reactive energy meters:
Disconnect all power factor correction systems**

**The check process is advisable to be
performed at full-load conditions**

8.1.- Checking mechanic energy meters

AR5 CHECK-METER			
User Name			(1) User's data
1/1V	5/5A		(2) P.T. and C.T. ratios
?	kWh		(3) Check of energy meters
?	TURNS III-ph.		
?	nTURNS?		(4) Check of mechanic energy meters
?	kWh START		
?	kWh END		
RECORD			(6) Saving check results
?	Wh	METER	(7) Check result
?	Wh	AR5	
- - - - %			(8) % Error
			

- Use the keys [▼] & [▲] to select the option to be modified.
- Press the key [SET], to modify the selected option.

- 1.- Enter user's attribute (Name, no. of contract). (1)
- 2.- Set transforming ratio of P.T. and C.T. (clamps) used for the checking action. (2)
- 3.- Type of energy meter: active or reactive energy meter. (3)
(ENERGY: kWh (Active) or kvarh (reactive)).
- 4.- Set the ratio of the mechanic energy meter: Energy x no. of turns. (3)
- 5.- Type of energy meter to be checked: single-phase/three-phase or ARON. (3)
- 6.- Press [ENTER] to start the energy meter checking process. After a confirmation inquiry, you will see at the bottom of the screen:



When pressing then [ENTER] the energy meter checking process will start.

- 7.- During some moments of data recording:



- 8.- You will see again at the bottom of the screen:



- 9.- The energy meter checking process will be stopped when pressing again [ENTER].

- 10.- Enter the no. of turns occurred during the checking process. (4)
- 11.- The % of error for the energy meter check in relation with the measurement performed by the AR5 will be shown at the bottom of the screen.
- 12.- Save check results. (5)

8.2.- Checking electronic energy meters

AR5 CHECK-METER		
User Name		(1) User's data
1/1V	5/5A	(2) P.T. and C.T. ratios
?	kWh	(3) Check of energy meters
?	TURN S III-ph.	
?	nTURN S?	
?	kWh START	(5) Check of electronic energy meters
?	kWh END	
RECORD		
		(6) Saving check results
?	Wh	(7) Check result
?	Wh	
	METER AR5	
		(8) % Error
	- - - - %	
		

- Use the keys [**▼**] & [**▲**] to select the option to be modified.
- Press the key [**SET**], to modify the selected option.

- 1.- Enter user's attribute (Name, no. of contract). (1)
- 2.- Set transforming ratio of P.T. and C.T. (clamps) used for the checking action. (2)
- 3.- Type of energy meter: active or reactive energy meter. (3)
(ENRGY: kWh (Active) or kvarh (reactive).
- 4.- Press [**ESC**] and disregard inquiries about the mechanic meter ratio. (3)
- 5.- Type of energy meter to be checked: single-phase/three-phase or ARON. (3)
- 6.- Press [**ENTER**] to start the energy meter checking process. After a confirmation inquiry, you will see at the bottom of the screen:



When pressing then [**ENTER**] the energy meter checking process will start.

- 7.- During some moments of data recording
- 8.- You will see again at the bottom of the screen:



- 9.- The energy meter checking process will be stopped when pressing again [**ENTER**].
- 10.- Enter the initial and ending energy readouts of the energy meter to be checked. (6)
- 11.- The % of error for the energy meter check in relation with the measurement performed by the AR5 will be shown at the bottom of the screen.
- 12.- Save check results. (5)

9.- TECHNICAL SPECIFICATIONS

Supply voltage:

Through an external power supplier set 230 V a.c. (+10% / -15%)
Frequency : 50...60 Hz
Burden : 8 VA
Operation temperature : 0 / 50 °C
Measuring circuit : SINGLE-PHASE, THREE-PHASE, ARON

Voltage measurement:

Measuring range : 20 to 500 V a.c. (phase-neutral)
20 to 866 V a.c. (between phases)
Automatic scale adjustment
Other voltages : through suitable voltage transformers
Frequency : 45 to 65 Hz

Current measurement:

Measuring range: according to current clamps
Current transducer ratio : user-programmable
Measurement units : automatic scale adjustment

Accuracy class:

- Current 0.5 % of readout \pm 2 digits
- Voltage 0.5 % of readout \pm 2 digits
- Active power 1.0 % of readout \pm 2 digits
- Reactive power..... 1.0 % of readout \pm 2 digits

Measuring conditions to assure accuracy class:

- Errors due to external voltage and current transformer not included
 - Temperature range : 5 °C to 45 °C
-

CONSTRUCTIVE CHARACTERISTICS OF THE CARTRIDGE

Case : Anti-chock plastic
Dimensions : 64 x 19 x 40 mm
Connection terminals : 1 input/output terminal

AR5 MECHANICAL CHARACTERISTICS

Case : Portable case.
Dimensions : 220 x 60 x 130 mm
Connection terminals : input/output terminals
Display : LCD, 160 x 160 pixels.
RS-232 type output : serial output.
Inner memory : 256 kb or 1 Mb according to the model.
Weight : 0,8 kg

RELEVANT STANDARDS

EN 60664, EN 61010, EN 61036, VDE 110 , UL 94

SAFETY :

- EN 61010-1 (1993) + A2 (1996) Category II - 600 V.

-

(According to result report no.:8120ISE..001)

ELECTROMAGNETIC EMISSION

- EN 61000-3-2 (1995), Harmonics.
- EN 61000-3-3 (1995), Voltage fluctuations.
- EN 50081-2 (1993), Industrial emission.
 - EN 55011 (1994): Conducted (EN 55022 – Class B).
 - EN 55011 (1994): Radiated (EN 55022 - Class A).

ELECTROMAGNETIC IMMUNITY

- EN 50082-2 (1995), Industrial immunity.
 - EN 61000-4-2 (1995), Electrostatic discharge.
 - ENV 50140 (1993), EM radiated field of RF.
 - EN 61000-4-4 (1995), EFT burst.
 - ENV 50141 (1993), RF common mode.
 - EN 61000-4-8 (1995), Magnetic field at 50 Hz.
- EN 50082-1 (1997), Residential immunity.
 - EN 61000-4-5 (1995), Surges.
 - EN 61000-4-11 (1994), Dips, interruptions.

(According to result report no.:08077IEM.002)

10.- SAFETY WARNINGS



The user should take into account all installation instructions referred in sections INSTALLATION AND STARTUP, CONNECTION INSTRUCTIONS and TECHNICAL SPECIFICATIONS of the analyzer.

Note that with the instrument powered on, the terminals could be dangerous to touching, and cover opening or elements removal actions may allow accessing dangerous parts. The analyzer has been designed and tested to meet IEC 348 standard and is factory-shipped in proper conditions.

11.- TECHNICAL SERVICE

For any inquiry about the instrument operation mode or in case of malfunction, you can contact CIRCUTOR S.A.'s technical service.

CIRCUTOR S.A. - Aftersales Service
Lepanto, 49
08223 - TERRASSA (SPAIN)
Tel: 34 - 93 - 745 29 00
Fax: 34 - 93 - 745 29 14
e-mail: ar5@circutor.es

A.- QUICK GUIDE - SETUP.

Menu		Description	Options	Standard	
Setup	Measure	Circuit	Choice type of measuring circuit.	Three-phase Single-phase ARON	
		Tr. Rel	Rel. V	Voltage transformers ratio.	Primary=1 Secondary=1
			Rel. A	Current transformers ratio.	Primary=5
		TR.Cal		Calibration parameters.	0
		Comm		Communication parameters setting	9600,n,8,1
		Clock		Analyzer's date and time setting	
	Recall		Recalling standard configuration	Standard	
Display			Contrast.		
Run			Enabling / Disabling data recording process in memory.	Stop. Run.	
Files	Dir		Directory of stored files.		
	Delete		Deleting a file.		
	Format		Clearing all memory content.		
Clear	Energy		Clearing energy meters.		

B.- QUICK GUIDE FOR AR5 - CHECK-METER.

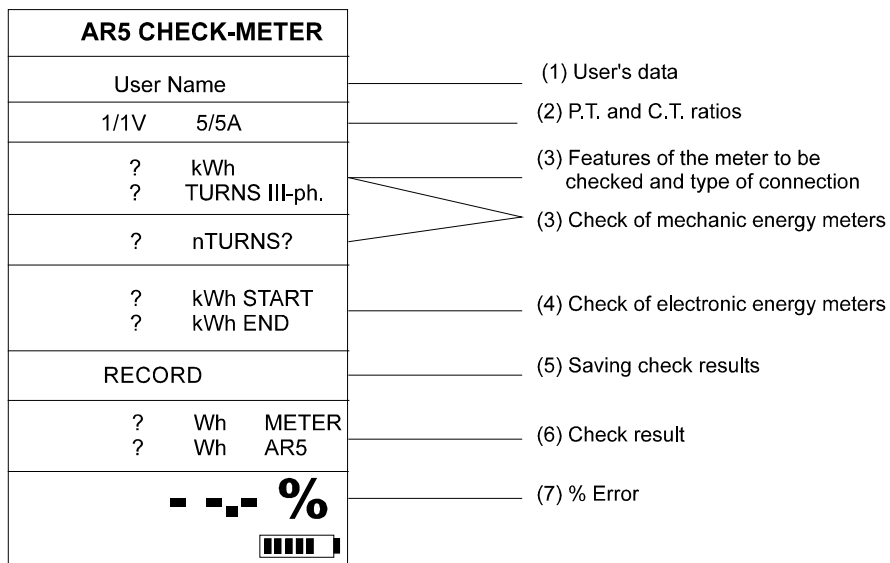

**Check of active energy meters:
Connect all power factor correction systems**

**Check of reactive energy meters:
Disconnect all power factor correction systems**

The check process is advisable to be performed at full-load conditions