



**ELECTRICITY POWER SUPPLY
QUALITY ANALYZER**

QNA 412

(Code Q20512 / Q20532 / Q20542)

USER MANUAL

(M98155501-03-07A)

(c) CIRCUTOR S.A.

QNA CONTENTS	page no.
1.- BASIC INSTRUCTIONS	3
1.1.- Checking the contents of your package.	3
1.2.- QNA-412 models.....	3
1.3.- Safety warnings.....	4
1.4.- Operating instructions	4
2.- MAIN FEATURES	4
2.1.- Basic features	5
2.2.- Electrical features.....	6
3.- ANALYSIS MODES	7
4.- DATA STORAGE IN MEMORY (automatic mode).....	7
5.- INSTALLATION & START-UP	8
5.1.- Connection terminal	9
5.1.1.- Models RS232/RS485 and GPRS/RS232.....	9
5.1.2.- Model ETHERNET.....	10
5.1.3.- Communications cables for RJ 11 connectors.....	11
5.2.- Starting the QNA-412 analyzer	12
5.3.- Connection diagram for the QNA-412.....	13
5.3.1.- 4 wire three-phase power systems	13
5.3.1.1.- Direct voltage and four current transformers	13
5.3.1.2.- Three voltage transformers (4 wire) and three current transformers	14
5.3.2.- 3 wire three-phase power systems	15
5.3.2.1.- Three voltage transformers (3 wire) and three current transformers (recommended MV installation).....	15
5.3.2.2.- Direct voltage (3 wire) and three current transformers	16
5.3.2.3.- Direct voltage (3 wire) and two current transformers (ARON) .	17
5.3.2.4.- Two voltage transformers (3 wire) and three current transformers	18
5.3.2.5.- Two voltage transformers (3 wire) and two current transformers (ARON).....	19
6.- THE QNA-412 ANALYZER'S INTERNAL BATTERY	20
7.- OPERATING MODE	20
7.1.- Display and buttons.....	20
7.2.- Turning the analyzer on	21
7.3.- Display screens.....	21
8.- SETTING UP THE QNA-412	22
8.1.- Operating setup of the QNA-412 analyzer	22
8.1.1.- Transformation ratios for voltage and current transformers	22
8.1.2.- Features of the monitored electrical system	23
8.1.3.- Quality parameters	23
8.1.4.- Data to take into account for the periodical data recording process .	26
8.2.- Selecting the parameters to be recorded	27
8.2.1.- Standard file (STD)	27
8.2.2.- EVENTS file (EVQ).....	28
8.2.3.- Incidents file (EVE)	29
8.2.4.- Harmonic statistics file (H24)	30
8.2.5.- Weekly average values file (STP).....	30

8.2.6.- Energy file (WAT)	31
8.2.7.- Setting and operation of the SMS alarms	31
8.2.8.- Setting and operation of the GPRS.....	31
9.- TECHNICAL SPECIFICATIONS	32
10.- SAFETY CONSIDERATIONS	34
11.- MAINTENANCE	34
12.- TECHNICAL SERVICE	34
A. Appendix: Communication with the QNA-412 connected to an external modem	35
B. Appendix: Communications with QNA-412 (RS-485).....	37
C. Appendix: Communications with QNA-412 using a TCP-IP converter.....	38
D. Appendix: Setting of a QNA-412 ETHERNET Analyzer	39
E. Appendix: Installation and start up of the <i>QNA-412</i> -GSM.....	43
F. Appendix: Installation and start up of the QNA-412-GPRS.....	45
G. Appendix: Setting the SMS Alarms	47
H. Appendix: QNA-412 measurement method.....	51

1.- BASIC INSTRUCTIONS

This manual is designed to familiarise the user with operating the power supply quality analyzer model **QNA-412** in order to get the best from its features.

QNA-412 is an analyzer specifically developed for supervising electrical power supply quality, which has been built with the most advanced technology in microelectronic components offering bench mark features in measuring and recording of electrical parameters in industrial power supply systems.

Please read this manual carefully before connecting and switching on the analyzer in order to avoid irreversible damage caused by improper use.

1.1.- Checking the contents of your package.

Please check the following points on receipt of the analyzer:

- a) The equipment delivered matches your order specifications.
- b) After unpacking, check that the equipment has not been damaged during delivery.
- c) Check that it is equipped with the following standard items:
 - 1 RS-232 Communications cable (female RJ-DB9)
 - 1 **QNA-412** User manual
 - 1 CD containing PC program and user guide
 - 1 GSM antenna (GPRS model only)

1.2.- QNA-412 models



Code	Model
Q20512	QNA – 412 RS232/RS-485
Q20532	QNA – 412 GPRS / RS-232 (SIM not included)
Q20542	QNA – 412 Ethernet

1.3.- Safety warnings

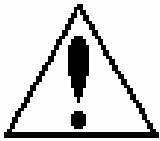

This manual contains information and warnings about the **QNA-412** analyzer which must be followed to guarantee the proper operation of all instrument functions and to maintain it in a safe condition.

If the instrument is not used in accordance with manufacturer's specifications, the instrument's protection may be damaged.

Where any protection failure is suspected to exist (for example, if there are signs of external damage), the instrument must be immediately switched OFF. In the event of this contact a qualified technician.

1.4.- Operating instructions

QNA-412 is a programmable instrument, with operating modes which may be selected from the available programming menus.

Before starting the QNA-412, carefully read the paragraphs on **INSTALLATION & STARTUP AND SETTING QNA-412**, to select the most suitable operating mode for your requirements.

Note that when the instrument is switched on, the terminals may be dangerous when touched and opening or removing parts may access dangerous areas. Therefore, the equipment must not be used until it is properly installed.

2.- MAIN FEATURES

The QNA-412 is an analyzer specifically designed to check electrical power supply quality in accordance with the IEC 61000-4-30 standard.

- Harmonic measurement in accordance with IEC 61000-4-7
- Flicker measurement in accordance with IEC 61000-4-15
- Measurement of main electrical parameters
 - Voltage, current, power, PF....
 - Harmonic distortion in Voltage and Current....
 - Neutral current and Neutral-Earth voltage
- 4-quadrant measuring system (Energy consumption and generation)
- High protection level against severe electrical conditions:
 - Wide range of supply and measurement voltages
 - High protection level against overvoltage and transient events
- Connection to either 3 or 4-wire distribution systems
- Wide voltage supply range: 100-400 V AC. $\pm 30\%$ / 90-730 V DC.
- Internal battery allowing the instrument to continue recording in the event of voltage supply loss
- 4 Mbytes internal memory for saving all parameters measured by the QNA-412 analyzer
- Communication via GPRS/GSM/RS-232/RS-485/ETHERNET (according to model)
- Mounted inside a self-extinguishing case. Dimensions and fixing points according to DIN 43857

2.1.- Basic features

The QNA-412 power supply quality analyzer (known hereafter as QNA-412) is an analyzer specifically designed to check electrical power supply quality in accordance with the IEC 61000-4-30 standard.

In addition to the A.C. voltage inputs (insulated by transformers), the instrument is equipped with 4 A.C. current inputs (3 phase + Neutral) which allows the QNA-412 to also be used as a power analyzer.

Its external design according to the DIN 43857 standard makes it ideal for any central energy meter board.

Moreover, the great variety of available models makes the QNA-412 suitable for any situation and communication mode.

The instrument's internal battery ensures continuity of measurement by the QNA-412 analyzer in the event of any loss in voltage supply (short or long-term line interruption).

QNA-412 is equipped with three A.C. voltage inputs and three A.C. current inputs which permit simultaneous analysis for all three phases in any power system (power supply quality).

To analyse electrical power supply quality in accordance with IEC 61000-4-30, the QNA-412 uses a DSP to analyse all cycles from all three voltage phases to detect the occurrence of any event (voltage dip, voltage interruption, overvoltage). Harmonic and flicker is also calculated in accordance with IEC61000-4-7 and 61000-4-15, respectively. The QNA-412's input current can analyse the main electrical parameters in 4 quadrants (Energy consumption and generation).

The QNA also has a Neutral current input and another for Neutral-Earth voltage measurement. These parameters complete the information that the QNA is able to supply to study the electric system.

The QNA-412 analyzer is equipped with a built in 4 Mbyte memory to receive quality, incidents and electrical parameters.

The different information recorded in the QNA-412's built in memory is distributed in six file types:

- *.STD files: this file contains all periodically recorded values (voltage, current, frequency, power, flicker, THD, unbalance...).
- *.EVE files: file containing all incidents referred to the QNA-412 itself (file readout, setup modification, memory erasure, auxiliary power supply on/off, battery on/off...).
- *.EVQ files: this file contains all events observed in the electrical power supply (voltage dips, voltage interruptions, overvoltages...) together with supplementary information about these events (time of the event occurring, maximum/minimum voltage, average voltage, voltage prior to the event).
- *.H24 files: this file contains the data required to obtain a statistical analysis of the harmonic evolution in one day.
- *.STP files: this file stores average values for voltage, frequency, flicker (pst and plt) and the THD over one week.
- *.WAT files: this file contains the three-phase active, inductive, capacitive and apparent energy.

Measurable parameters by the QNA-412 analyzer are listed below:

Parameter	L1	L2	L3
Voltage	X	X	X
Current	X	X	X
Frequency	X		
Active power	X	X	X
Inductive reactive power	X	X	X
Capacitive reactive power	X	X	X
Apparent power		X	
Active energy		X	
Inductive reactive energy		X	
Capacitive active energy		X	
Power factor	X	X	X
Voltage THD	X	X	X
Current THD	X	X	X
Voltage harmonic content	X	X	X
Current harmonic content	X	X	X
Type of voltage wave	X	X	X
Type of current wave	X	X	X
Neutral current		X	
Neutral-Earth Voltage		X	
Flicker (PST)	X	X	X
Dips	X	X	X
Interruptions	X	X	X
Overvoltage	X	X	X
Vrms in event semi-cycle	X	X	X
Voltage unbalance		X	
Voltage asymmetry		X	
Current unbalance		X	
Current asymmetry		X	

The above parameters will be measured and recorded regardless of energy consumption or generation in the installation.

2.2.- Electrical features

Using the QNA-412 as a recording instrument for evaluating electrical power supply quality means that the analyzer must have a high degree of protection against severe electrical conditions:

- High-energy varistors absorbing surges to avoid any costly repairs.
- Noise filters in voltage and current inputs to ensure reliable measurements even under the most adverse operation conditions.
- Power supply: transformers with extra power dissipation and insulation.
- Built-in battery power supply to ensure voltage supply to the QNA-412 analyzer in the event of voltage loss.
- Insulation transformers guaranteeing the proper insulation of inputs.

3.- ANALYSIS MODES

QNA-412 series analyzers can be used in different operating modes according to their setting.

The most striking features of the analysers are:

- Measurement and storage in memory of main power quality parameters (voltage values, flicker, harmonics and unbalance).
- Measurement and storage in memory of main electrical parameters (voltages, currents, frequency, power, PF...).
- Neutral current and Neutral-Earth voltage measurement.
- Setting a voltage threshold to define different events (voltage dips, voltage interruptions and overvoltages). Also an optional setting of an hysteresis value for each individual threshold.
- QNA-412 can carry out quality analyses in 3-wire or 4-wire distribution systems. All quality measurements will be referred the line-to-neutral or line-to-line voltage according to selection.

QNA-412 can also be used to measure through voltage and current measuring transformers.

4.- DATA STORAGE IN MEMORY (automatic mode)

QNA-412 is equipped with an internal date and time clock to store automatic data recordings and quality events in the memory at regular time intervals.

The QNA-412 storage memory is divided into four independent blocks (FIFO type). Each discrete block is allocated to every file type to be saved. Every file type contains the following information:

- *.STD files: this file contains all periodically recorded values (voltage, current, frequency, power, flicker, THD, unbalance...).
- *.EVE files: file containing all incidents referred to the QNA-412 itself (file readout, setup modification, memory erasure, auxiliary power supply on/off, battery on/off...).
- *.EVQ files: this file contains all events observed in the electrical power supply (voltage dips, voltage interruptions, overvoltages...) together with supplementary information about these events (time of the event occurring, maximum/minimum voltage, average voltage, voltage prior to the event).
- *.H24: this file contains the data required to obtain a statistical analysis of the harmonic evolution in one day.
- *.STP files: this file stores average values for voltage, frequency, flicker (pst and plt) and the THD over one week.
- *.WAT files: this file contains the three-phase active, inductive, capacitive and apparent energy.

QNA-412 is equipped with a built in rotating memory for data collection (FIFO); this means that once this memory is full, new values overwrite the oldest ones. Therefore, if no data is to be lost, data must be retrieved from the memory before the oldest values are overwritten.

5.- INSTALLATION & START-UP



This manual contains information and warnings about the QNA-412 analyzer which must be followed to guarantee the proper operation of all instrument functions and to maintain it in a safe condition.

If the instrument is not used in accordance with manufacturer's specifications, the instrument's protection may be damaged. Note that when the instrument is switched on, the terminals may be dangerous when touched and opening or removing parts may access dangerous areas. Therefore, the instrument must not be used until it is properly installed.

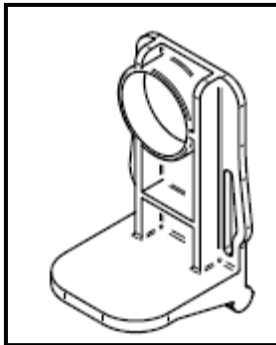

IMPORTANT: This part must be removed so that the instrument's battery can operate. It must be removed when installing the instrument, just before the equipment is powered. The instrument's power supply must be connected for at least 8 hours the first time it is connected to ensure that the battery is correctly charged.

Where any protection failure is suspected to exist (for example, if there are signs of external damage), the instrument must be immediately switched OFF. In the event of this contact a qualified technician.

5.1.- Connection terminal

5.1.1.- Models RS232/RS485 and GPRS/RS232

	Terminal No.	Terminal description
	Upper connection terminal	
	21	Measurement VL1
	22	Common L1
	23	Measurement VL2
	24	Common L2
	25	Measurement VL3
	26	Common L3
	27	Neutral
	28	Ground
	29	Not used
	30	Not used
	31	Not used
	32	Not used
	33	Not used
	34	Not used
35	Not used	
	Lower connection terminal	
	1	Current measurement IL1 S1
	2	Current measurement IL1 S2
	3	Current measurement IL2 S1
	4	Current measurement IL2 S2
	5	Current measurement IL3 S1
	6	Current measurement IL3 S2
	7	Neutral current measurement S1
	8	Neutral current measurement S2
	9	Power supply voltage input
	11	Power supply voltage input
	R1	RS-232
	R2	RS-485 / GSM Antenna (According to the model)

The QNA-412 analyzer may be installed in any three-phase distribution line with neutral conductor (4 wires) or without neutral conductor (3 wires). Measurements solely depend on the connection mode and the analyzer configuration.

The connection of an earth terminal is essential to ensure the efficiency of QNA-412 protection elements.

5.1.2.- Model ETHERNET

	Terminal No.	Terminal description
	Upper connection terminal	
	21 22 23 24 25 26 27 28 29 30 31 32 33 34 35	Measurement VL1 Common L1 Measurement VL2 Common L2 Measurement VL3 Common L3 Neutral Ground Not used Not used Not used Digital input 1 Common input 1 Digital input 2 Common input 2
	Lower connection terminal	
	1 2 3 4 5 6 7 8 9 11 R1 R2	Current measurement IL1 S1 Current measurement IL1 S2 Current measurement IL2 S1 Current measurement IL2 S2 Current measurement IL3 S1 Current measurement IL3 S2 Neutral current measurement S1 Neutral current measurement S2 Power supply voltage input Power supply voltage input ETHERNET

5.1.3.- Communications cables for RJ 11 connectors

The RJ connection is different for each QNA-412 model. To see ETHERNET connector, look at Appendix D. Thus:

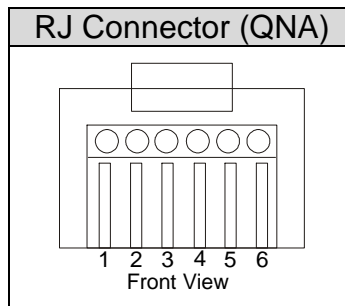
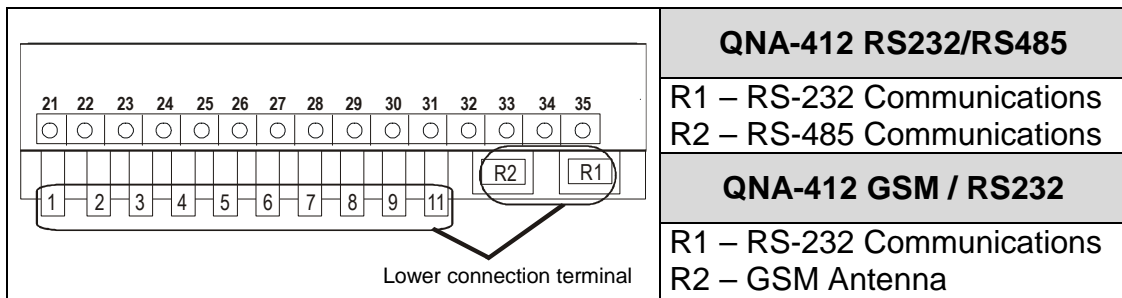

The most usual configurations for QNA-412 communication cables are as follows:

- RS-232 connection to PC or to an external modem:

QNA-412	PC		External Modem	
	DB9	DB25	DB9	DB25
1-DSR	5-GND	7-GND	5-GND	7 - GND
2-Rx	3-Tx	2-Tx	2-Rx	3 - Rx
3-TX	2-Rx	3-Rx	3-Tx	2 - Tx
4-CTS	7-RTS	4-RTS	8-CTS	5 - CTS
5-RTS	8-CTS	5-CTS	7-RTS	4 - RTS
6-GND	5-GND	7-GND	5-GND	7 - GND

- RS-485:

QNA- 412	RS-232/485 (DB9) Converter
2-Tx/Rx(-)	2-Tx/Rx (-)
3-Tx/Rx(+)	1-Tx/Rx (+)
6-GND	5-GND

The RS-232 communication cables must always be disconnected to establish communication with a QNA-412-GSM via a mobile phone. If the RS-232 is connected, then modem operation is completely disabled.

5.2.- Starting the QNA-412 analyzer

Please check following points before switching on the analyzer:

- 1) Mains supply voltage:
Voltage: 100-400 V AC. \pm 30% / 90-730 V DC.
Frequency: 50... 60 Hz.
- 2) Earth terminal: The earth terminal of the analyzer must be connected to earth. If it is not connected some of the protective parts may not work properly.
- 3) Maximum voltage in the voltage measurement circuit: 500 V AC. between phase and common:
 - 4-wire configuration: 500 VAC. line-to-neutral. / 866 VAC. line-to-line.
 - 3-wire configuration: 500 VAC. line-to-line.
- 4) Maximum voltage in the Earth measurement circuit: 500 V AC. between Neutral-Earth
- 5) Maximum permissible measurement current: According to transformers used. In / 5 A AC.
- 6) Burden: 16 VA – 8 W
- 7) Operating conditions:
 - Operating temperature range: 0°C to 50°C.
 - Storage temperature: -20° to 70°C
 - Operating humidity: 0% to 90 % RH.
- 8) Safety: Designed to meet protection class III according to EN 61010.

Points to check during the installation process:

- 9) Check that the earth terminal of QNA-412 is connected to earth to avoid any possible interference to the analyzer. If this earth terminal is not connected, then the effectiveness of the QNA-412 protection elements may be reduced.
- 10) Check power readouts and their sign (check current measurement transformer polarity).
- 11) Verify the QNA-412 setup.

Points to consider:

Voltage values flashing on the display is a sign that the analyzer is incorrectly installed or configured. Possible causes might be:

- The analyzer detects an event. This can mean a real event in the system, or a wrong rated voltage setting where the set value does not match the actual system voltage.
- **If the unbalance screen displays dashes**, there is an incorrect phase sequence.

5.3.- Connection diagram for the QNA-412

5.3.1.- 4 wire three-phase power systems

5.3.1.1.- Direct voltage and four current transformers
(L1-L2-L3-N):

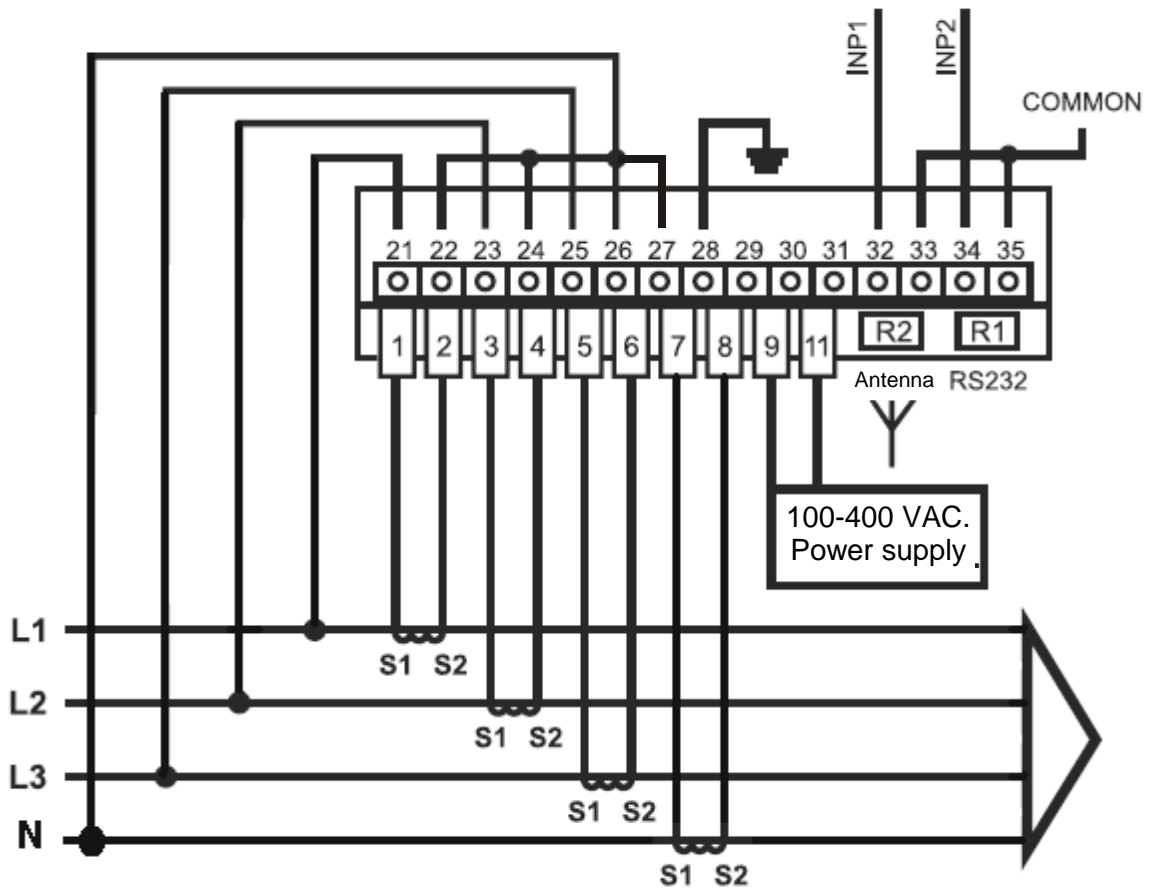

5.3.1.2.- Three voltage transformers (4 wire) and three current transformers (L1-L2-L3):

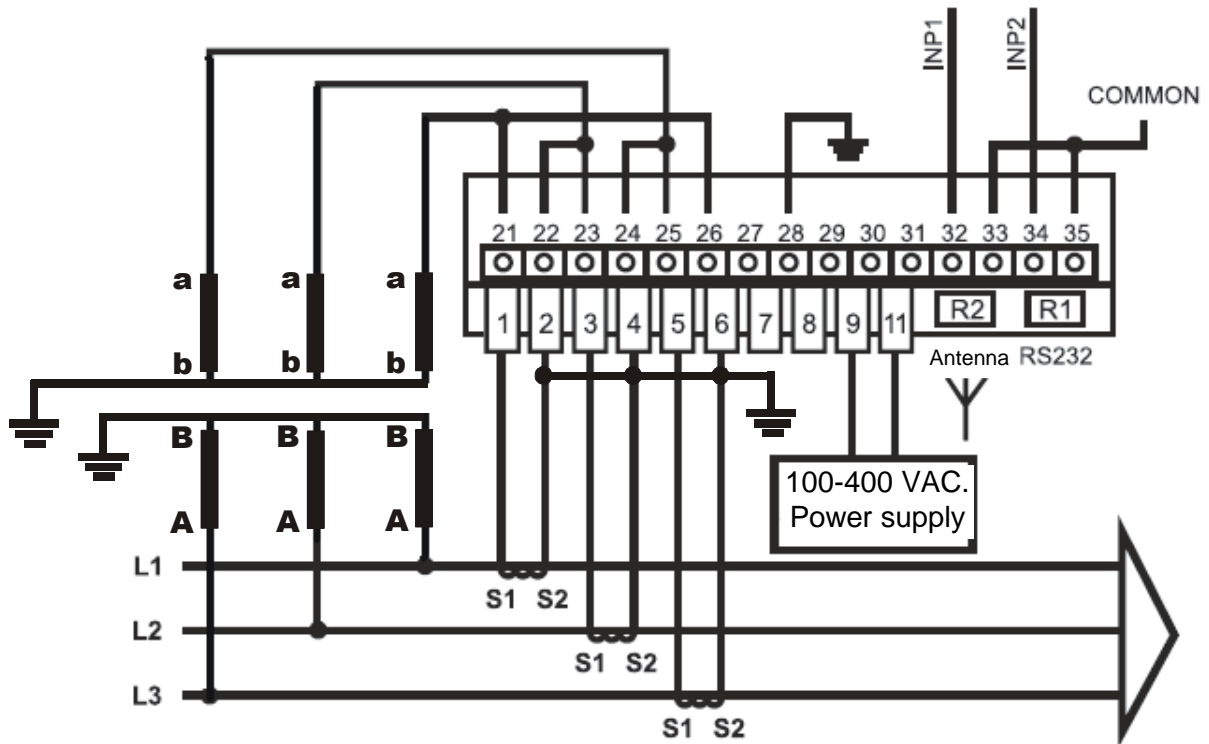

5.3.2.- 3 wire three-phase power systems

5.3.2.1.- Three voltage transformers (3 wire) and three current transformers (recommended MV installation)

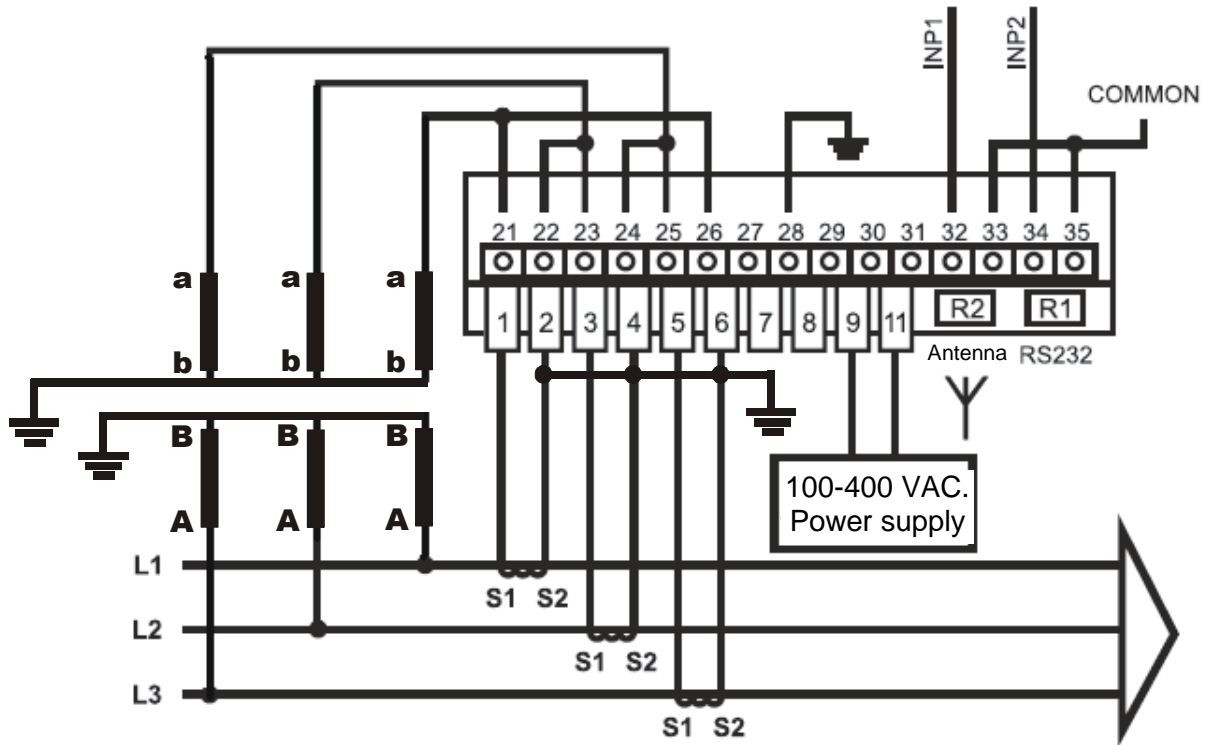

5.3.2.2.- Direct voltage (3 wire) and three current transformers

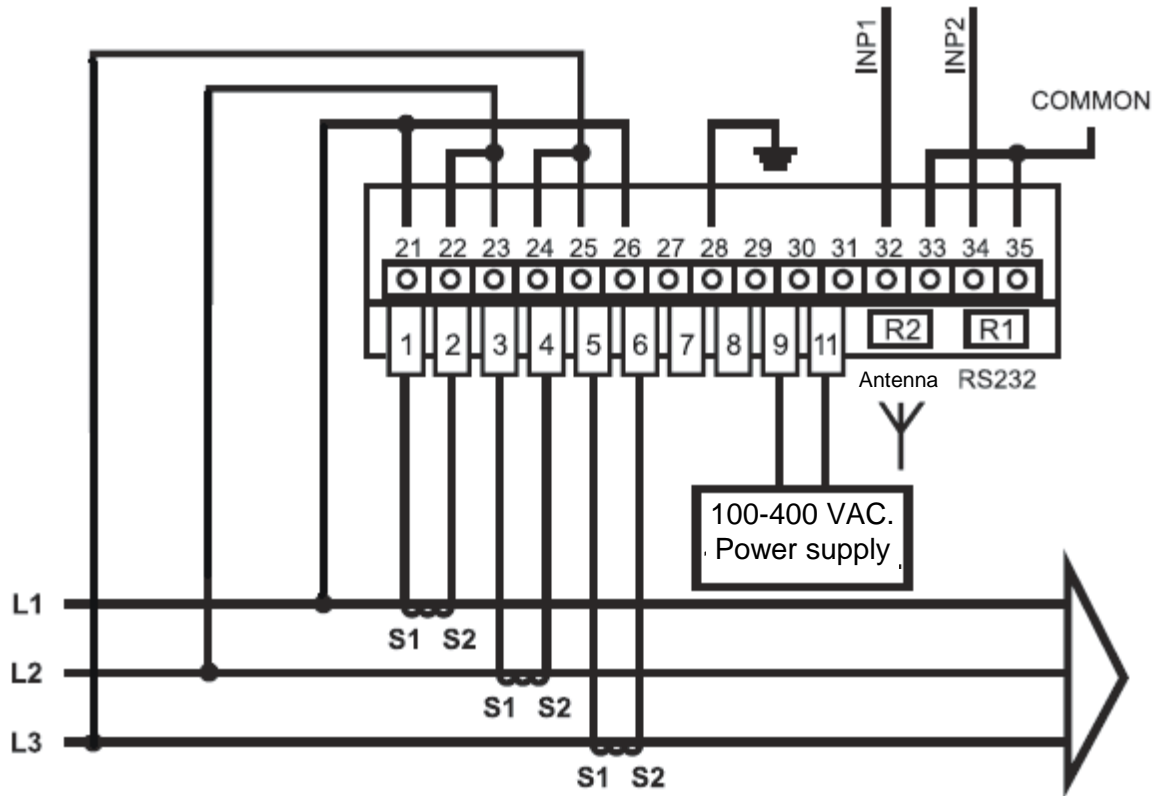

5.3.2.3.- Direct voltage (3 wire) and two current transformers (ARON)

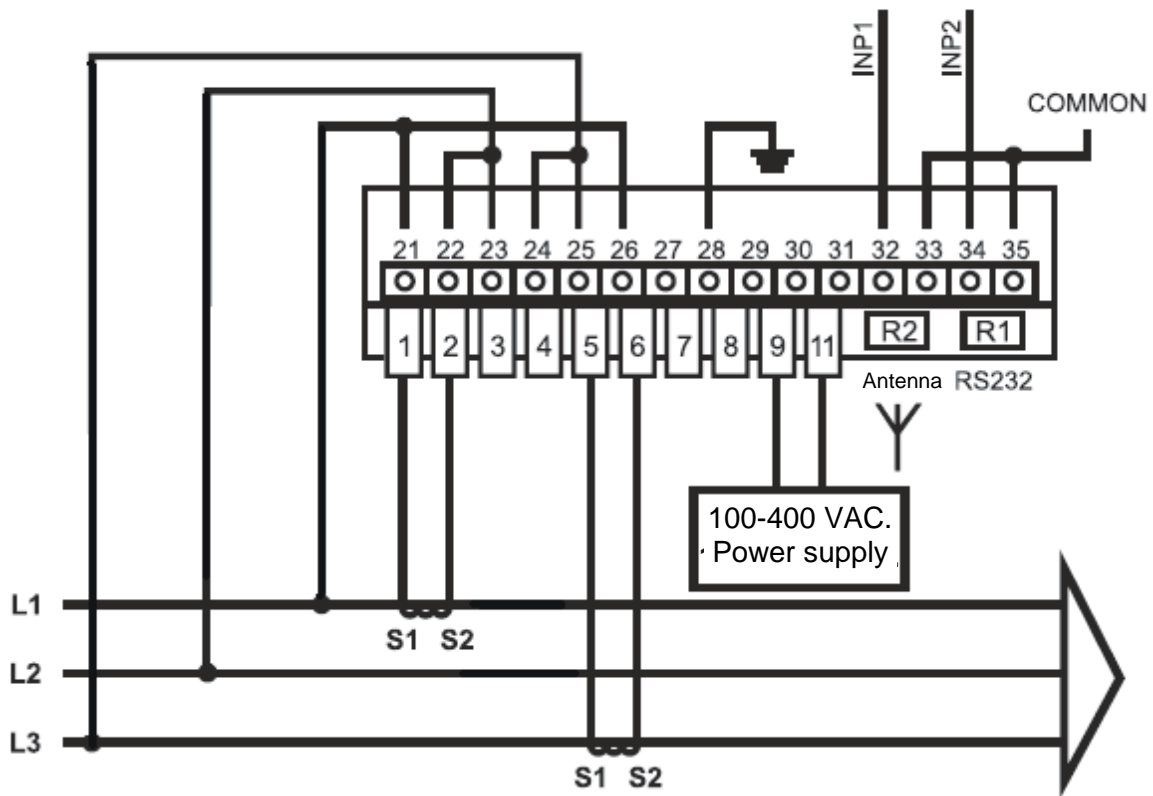

5.3.2.4.- Two voltage transformers (3 wire) and three current transformers

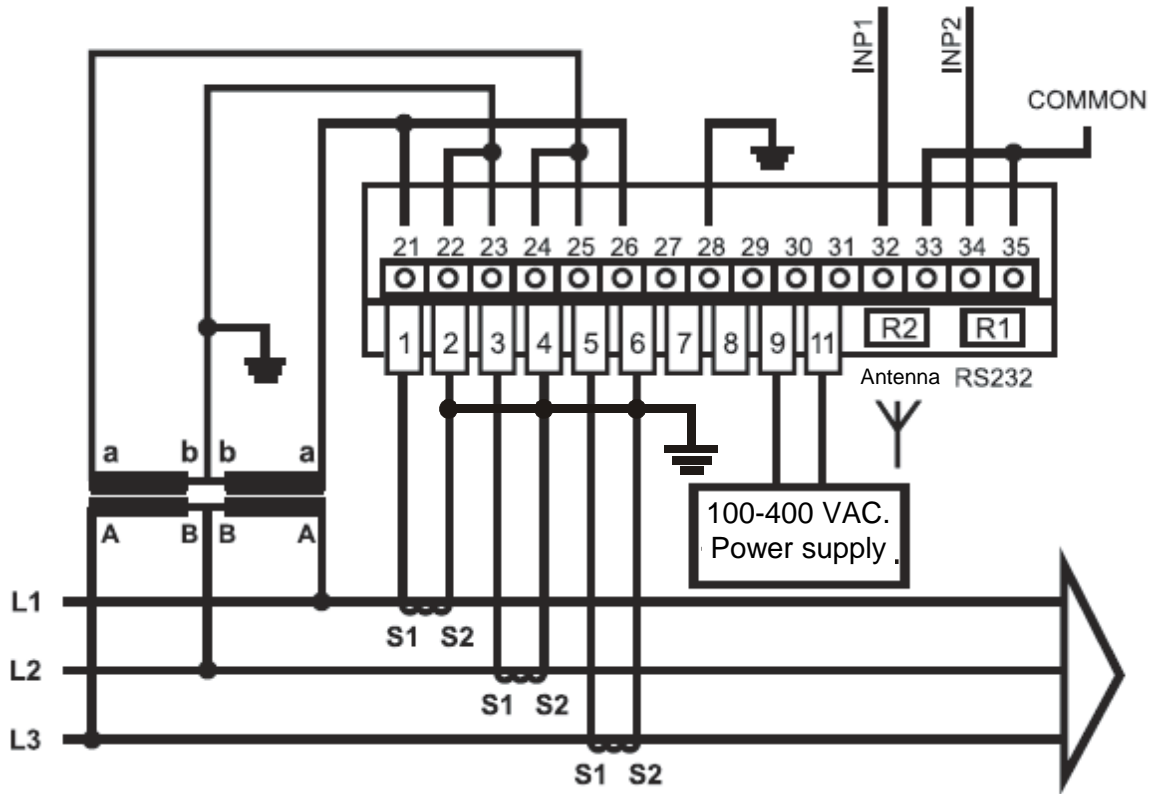

5.3.2.5.- Two voltage transformers (3 wire) and two current transformers (ARON)

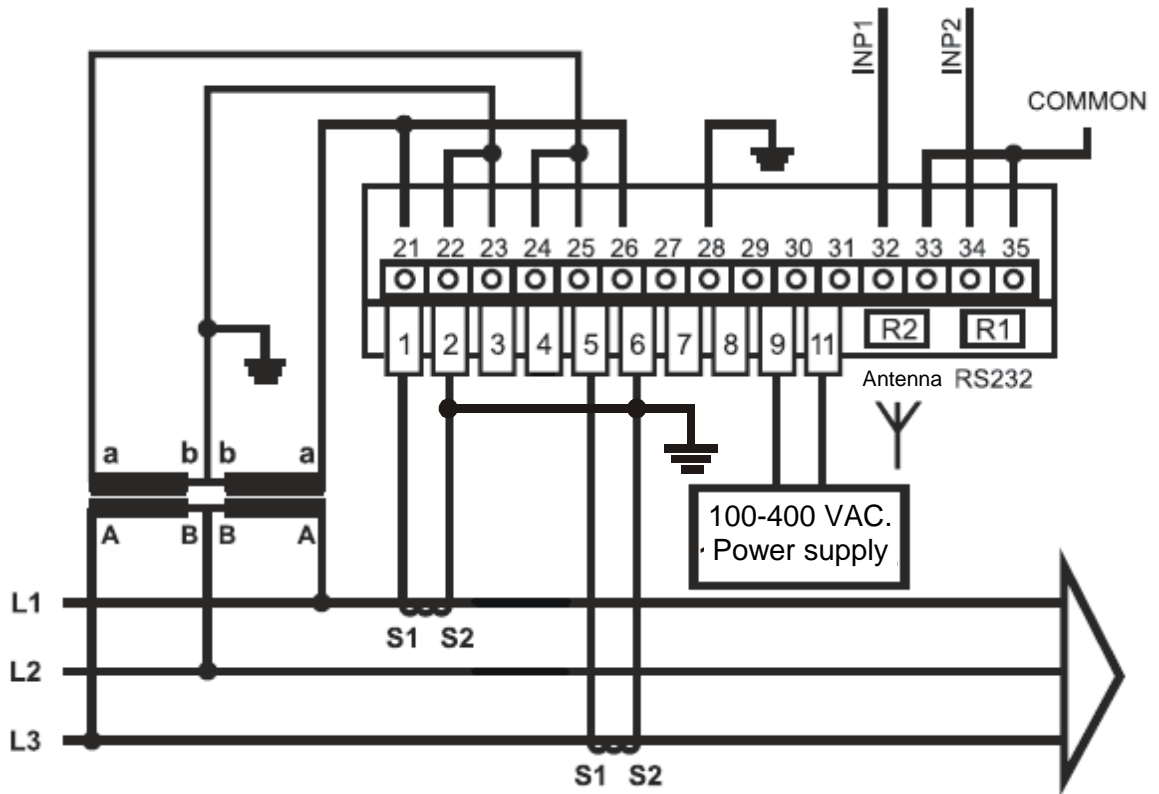

6.- THE QNA-412 ANALYZER'S INTERNAL BATTERY

The analyzer has an internal battery to ensure power supply to the analyzer when any event occurs. This battery keeps the analyzer continuously powered as a default for 15 minutes without mains supply for a maximum of 9999 seconds in the event of the mains power supply being cut. This operating period after voltage supply loss is user-programmable in order to save the battery and to ensure that any possible intermittent voltage interruptions are detected.

The guarantee of a 9999 second operating period is essential to ensure the proper detection and recording of multiple and long-term voltage interruptions.

The battery is charging when the analyzer is connected to the mains.

The QNA-412 analyzer is equipped with an intelligent energy charging system. This means that the instrument continuously and automatically checks the status of the battery. This means that the charging process stops when the battery is on maximum charge level and, therefore, the life of the battery is increased.



7.- OPERATING MODE

7.1.- Display and buttons

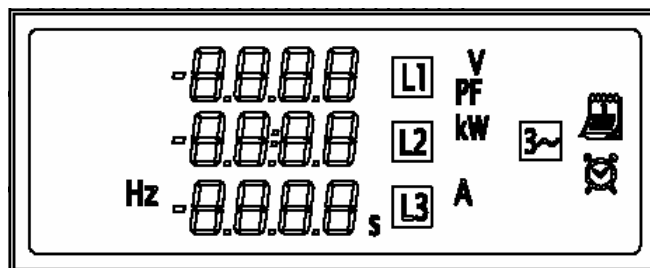
QNA-412 is equipped with a display to show all information being measured by the analyzer using different buttons.



The function of each button on the QNA-412 analyzer is:

-  (Next screen): The next display screen is accessed.
-  (Previous screen): The previous display screen is accessed.

7.2.- Turning the analyzer on

When the QNA-412 is turned on, the first screen appears with the analyzer's identification.















After a few seconds, the display will show a screen displaying the three voltages measured by QNA-412 in each phase.

Use the  and  buttons to move through each available display screen.

7.3.- Display screens

The available display screens on the QNA-412 analyzer are as follows:

	<p> Voltage measured in the system</p>
	<p> Current measured in the system</p>
	<p> Active power kw without flicker = kW kw with flicker = MW</p>
	<p> Power factor</p>
	<p> Unbalance rate  Asymmetry rate  Frequency</p>
	<p> Unbalance rate  Asymmetry rate</p>
	<p>Date  Day / month  Year</p>
	<p>Clock  Hours / minutes  Seconds</p>

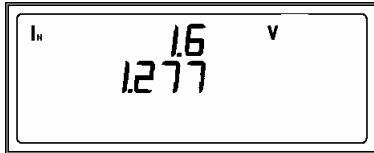

- ☞ Neutral-Earth Voltage
- ☞ Neutral current

Notes

The QNA-412 analyzer may indicate that it is incorrectly installed or configured. Possible causes might be:

- Voltage values **flashing on the display**. Possible causes might be:
 - The analyzer detects an event. This can mean a real event in the system, or a wrong rated voltage setting where the set value does not match the actual system voltage.
 - If the **unbalance screen displays dashes**, there is an incorrect phase sequence.
- Power screens with a negative sign:
 - The installation is generating energy, or the current transformer polarity is inverted.
 - The PF values are wrong. Check the voltage and current phase wiring, the phase sequence is probably not correct.

8.- SETTING UP THE QNA-412

Any setup action for the QNA-412 analyzer must be always done via a PC.

The **QNA-412** analyzer's performance will depend on the user-configuration of the instrument. There are two different setup procedures for configuring the analyzer:

- Operating Setup: to define the **QNA-412** analyzer's operating mode.
- File Setup: to define the data collection procedure of the **QNA-412** analyzer in the internal memory.

8.1.- Operating setup of the QNA-412 analyzer

The user defined procedures are listed below:

8.1.1.- Transformation ratios for voltage and current transformers

The QNA-412 analyzer can measure via transformers.

- **Voltage primary value / Voltage secondary value:** setting the transformation ratio for voltage transformers used in measuring. Set 1/1 for direct voltage measurement (no voltage transformer used). This ratio must not exceed 9999.

- **Current primary value:** setting the primary value for the current transformers used in measuring.
- **Neutral current primary value:** setting the primary value of the current transformer used in measuring Neutral current.

8.1.2.- Features of the monitored electrical system

- **Rated voltage:** the rated voltage of the power system to be monitored by the QNA-412 analyzer. For a 3-wire configuration the line-to-line voltage must be set (ex. 400 V~), and for a 4-wire configuration the line-to-neutral voltage must be set (ex. 230 V~). If a voltage measurement transformer is used, then the rated voltage to be set must be referred to the secondary side (ex. 63.5 V~). Correct configuration is essential because the limits for the analysis of the quality of electrical power supply are to be analysed.
- **Rated frequency:** the rated frequency of the power system to be monitored by the QNA-412 analyzer. This parameter is necessary for the calculation of the RMS signal value in extreme quality systems.
- **3 Wire / 4 Wire:** The QNA-412 analyzer must be set according to the distribution system to be monitored, whether with neutral conductor (4 wires) or without neutral conductor (3 wires). The proper setting of this point is essential to ensure the correct detection of events. This choice must also match the external connection configuration.
- **Circuit type:** when measurement is via three current sensors, then the analyzer must be set to operate with a three-phase circuit. For 3-wire networks, that is, systems without neutral conductor, the analyzer can be set to work in an ARON system. Here only two current sensors are required.

8.1.3.- Quality parameters

In order to determine electrical power supply quality, the voltage levels defining the event must be set beforehand.

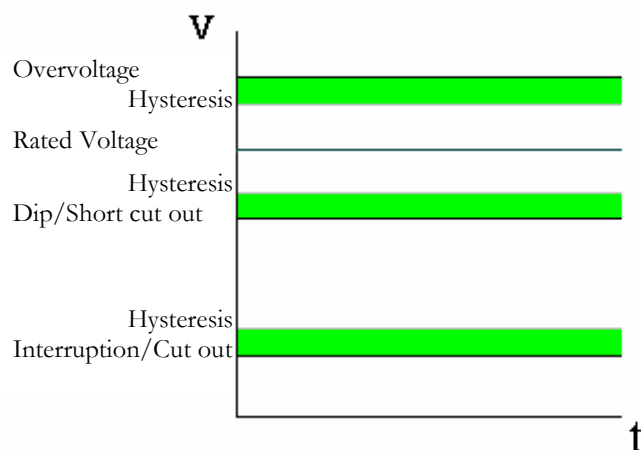

Therefore, following points must be user-defined:

- **% of overvoltage threshold:** the detection of a overvoltage depends on the value set for this point (% of the rated voltage). Every semi-cycle with a RMS value over this threshold is said to be an overvoltage. A record will be kept in

the events file (EVQ) every time this limit is exceeded, with the indication of the phase, the maximum voltage value detected, the voltage average value, voltage value previous to the event and the duration of the overvoltage event.

- **Overvoltage hysteresis:** a overvoltage hysteresis value can be defined at a different value for the overvoltage event starting and finishing. Therefore, an overvoltage event starts when the overvoltage threshold is exceeded and ends when the voltage value is below the value defined by subtracting the overvoltage hysteresis value from the overvoltage threshold.
- **% of voltage dip threshold:** the detection of a voltage dip depends on the value set for this point (% of the rated voltage). Every semi-cycle where the RMS value is below this threshold is said to be a voltage dip. A record will be saved in the events file (EVQ) every time this limit is exceeded indicating the minimum voltage value detected, the average voltage value and the duration of the voltage dip event.
- **Voltage dip hysteresis:** a voltage dip hysteresis value can be defined at a different value for the voltage dip event starting and finishing. Therefore, a voltage dip event starts when the voltage dip threshold is not reached and ends when the voltage value is over the value defined by adding the voltage dip hysteresis value to the voltage dip threshold.
- **% of interruption threshold:** the detection of an interruption depends on the value set for this point (% of the rated voltage). Every semi-cycle where the RMS value is below the defined limit is said to be an interruption. A record will be saved in the events file (EVQ) every time this limit value is exceeded indicating the minimum voltage value detected, the average voltage value and the duration of the interruption event.
- **Interruption hysteresis:** an interruption hysteresis value can be defined at a different value for the interruption event starting and finishing. Therefore, an interruption event starts when the interruption threshold is not reached and ends when the voltage value is over this threshold by adding this threshold plus the hysteresis set here.
- **STD file recording period:** part of the memory allocated for this file, expressed in days. This is a not modifiable value, and it will depend on the recording period and the memory allotted for other files and the variables selected in Setup.
- **Number of recordings in the EVE file:** part of the memory allocated for the incidents file, expressed as the number of incidents.
- **Number of recordings in the EVQ file:** part of the memory allocated for the events file, expressed as the number of events.
- **No. of days in the H24 file:** display of the H24 file showing maximum number of days in the recording.
- **No. of weeks in the STP file:** display of the maximum number of weeks of recording for the STP file.
- **Number of recordings of the WAT file:** part of the memory allocated for the energies file, expressed as the number of energies.

QNA 412 (with default variables)	Default
STD	67 days 8 hours 20 min
EVE	4665 recordings
EVQ (minimum)	342 recordings
H24	32 days
STP	16 weeks
WAT	3106 recordings

(*) The STD file has been calculated assuming a 10-minute recording period, and the default parameters of the STD file.

8.1.4.- Data to take into account for the periodical data recording process

Some points to allow the user to precisely define the information to be used for the recording calculation procedure.

Therefore, the user can define:

- **Description of the measurement site:** an identifying field to be filled in by the user.
- **Note:** an information field to be filled by the user.
- **Recording period:** all electrical parameters will be recorded at the end of the preset time (those parameters selected only). The average values obtained during that period of time will be recorded. The recording period is, by default, set at 10 minutes, but this value is user-settable from 1 minute to 2 hours.
- **Integration of 10-cycle blocks with events (all except for voltage):** (affecting the .STD file only). An event might occur (overvoltage, dip, ...) while the analyzer is calculating the voltage, flicker, harmonic averages. The QNA-412 allows the 10-cycle block where the event occurred to be added to the integration. If this option is disabled ("No"), then the 10-cycle block would be only added to the voltage average.
- **Integration of 10-cycle blocks with events (voltage):** (affecting the .STD file only). An event (overvoltage, dip,...) may occur while the analyzer is calculating the average voltage. The QNA-412 allows the 10-cycle block where the event occurred to be added to the integration (this may be for one or more event, depending on the duration of the event). If this option is disabled ("No"), then the 10-cycle block would be ignored, and, therefore, it would not be added to the integration for this periodical recording. This option does not affect the other parameters.
- **Recording period:** (affecting the .STD file only). This is the period in which the averaged values are stored.
- **Date type:** (affecting the .STD file only). Permits the user to select date/time to be saved together with each recording. This date can be the initial or final recording.
- **Recording period of energies:** (affecting the .WAT file only). All three-phase energies will be recorded at the end of the preset time. The average values obtained during that period of time will be recorded. As default the recording period is set at 15 Minutes. This value may range from 1 minute to 2 hours.
- **Ignoring incomplete records in the STP file:** (affecting the .STP file only). Records which are incomplete may be ignored ("SI") or ("NO") incomplete files not ignored.
- **Battery auto-power off timer:** the user can set the time for the QNA-412 battery auto-power to switch off in the event of supply voltage loss, in order to save the battery and to ensure the detection of possible intermittent voltage interruptions. The usual time is about 15-30 min.

8.2.- Selecting the parameters to be recorded

The QNA-412 saves all quality parameter recordings in its internal memory. The different information recorded by the QNA-412 is distributed in three file types.

8.2.1.- Standard file (STD)

The standard file (STD) is used to store all periodically recorded parameters.

The following electrical parameters will be saved in the memory during the user-defined recording period:

Parameter	L1	L2	L3	File
Voltage (Line-to-Neutral or Line-to-Line)	X	X	X	STD
Current	X	X	X	STD
Frequency	X			STD
Apparent power		X		STD
<i>Energy consumption</i>				
Active power	X	X	X	STD
Inductive reactive power	X	X	X	STD
Capacitive reactive power	X	X	X	STD
Power factor	X	X	X	STD
Active energy		X		WAT
Inductive reactive energy		X		WAT
Capacitive reactive energy		X		WAT
<i>Energy Generation</i>				
Active power	X	X	X	STD
Inductive reactive power	X	X	X	STD
Capacitive reactive power	X	X	X	STD
Power factor	X	X	X	STD
Active energy		X		WAT
Inductive reactive energy		X		WAT
Capacitive reactive energy		X		WAT
Neutral current		X		STD
Neutral-Earth Voltage		X		STD
<i>Harmonics</i>				
Voltage THD	X	X	X	STD
Current THD	X	X	X	STD
Voltage harmonic content (Selection of any harmonic between 2-50)	X	X	X	STD
Current harmonic content (Selection of any harmonic between 2-50)	X	X	X	STD
Wave types (V, I)		X		STD
Flicker (PST)	X	X	X	STD
<i>Quality</i>				
Dips	X	X	X	EVQ
Interruptions	X	X	X	EVQ
Overvoltage	X	X	X	EVQ

Unbalance		
Voltage unbalance	X	STD
Voltage asymmetry	X	STD
Current unbalance	X	STD
Current asymmetry	X	STD

* The STD file will record the average values of the electrical parameters

➤ Flicker

- **Pst:** the QNA-412 saves the Flicker value (Pst) obtained over the recording period. The Plt value will be calculated by the data analysis software in the PC.

➤ Harmonics

- **Harmonic distortion:** the QNA-412 will calculate and record in the memory the value of the average voltage harmonic distortion detected in the monitored power system.
- **Harmonic content:** the QNA-412 will calculate and record in the memory the average value of the individual harmonic distortion rate for each voltage harmonic in the monitored power system (up to the 40th harmonic). (Harmonic content of each 10-cycle blocks which have been integrated over a recording period).
- **Direction of the harmonics:** the QNA-412 allows the direction of the individual harmonics to be displayed, indicating if a specific harmonic is being generated by the user or is being generated outside the installation.

➤ Wave types

- **Voltage:** records one cycle of the voltage signal wave type on finishing the recording.
- **Current:** records one cycle of the current signal wave type on finishing the recording.

➤ Unbalance

- **Voltage asymmetry rate:** ratio of homo-polar voltage to direct voltage.
- **Voltage unbalance rate:** ratio of inverse voltage to direct voltage.
- **Current asymmetry rate:** ratio of homo-polar current to direct voltage.
- **Current unbalance rate:** ratio of inverse current to direct current.

8.2.2.- EVENTS file (EVQ)

The analyzer also records an events file containing information on any event detected in the monitored power system. The following data is saved about each event.

Event date: indication of the time of the event. This value is obtained with an accuracy of one cycle.

Type of event: indication of the event type, i.e. a voltage interruption, a voltage dip or an overvoltage. These events are defined in accordance with the QNA-412 setup. The type of event also identifies the phase where this event occurred.

Duration of the event: period of time in milliseconds that the event lasted.

Maximum/minimum voltage for the event: in the event of an interruption or voltage dip, the minimum RMS $\frac{1}{2}$ (*) voltage value obtained during the event. In the event of an overvoltage, the maximum values will be recorded.

Average voltage for the event: the average RMS $\frac{1}{2}$ (*) voltage value during the event.

Voltage prior to the event: the RMS $\frac{1}{2}$ (*) voltage value before the event occurrence is recorded.

(*) RMS $\frac{1}{2}$ cycle value: RMS value of a complete cycle, refreshed every semi-cycle.

Graph of the Vrms semi-cycle value for the event: this option shows the setting for the event. The Vrms value for each semi-cycle during the event may be seen. The equipment also records 1.5 seconds before the event starting and 0.5 seconds after it finishes. This way the setting for the event is obtained for better analysis.

8.2.3.- Incidents file (EVE)

All incidents sent to the QNA-412 are automatically saved in this file, with an indication of the time and type of incident. The following incidents may be detected and recorded by the QNA-412.

Battery OFF: indication of the time when QNA-412 stopped operating. This time depends on the value set by the user for the operating period after a voltage supply loss.

Auxiliary power supply ON: indication of the time when the QNA-412 analyzer was connected to an external power supply.

Auxiliary power supply OFF: indication of the time when the external power supply for the QNA-412 analyzer was interrupted. The analyzer is supplied from the internal battery from this time.

Setup modification: record of the time when the instrument's setup was modified.

Memory formatting: indication of the time when the user decided to format the QNA-412's internal memory.

Forced memory formatting: the QNA-412's internal memory will be automatically formatted if any error in this internal memory is detected.

File deletion: indication of the time when the user deleted a file from the QNA-412's internal memory. If the first data shown by the .EVE file indicates that a file has been deleted, then the deleted file was the events file.

Time change: indication of any change to the date or time of the analyzer's internal clock. Recording this event type is quite important, because if the time intervals between two successive readouts are observed to be erroneous, this might be due to a change to the time of the internal clock.

Alarm activated: (for GSM instruments only). Indication that the condition for activating one of the programmable alarms has been met, indicates the number of the activated alarm.

Alarm sent: (for GSM instruments only). Indication that the alarm has been sent and also to which of the preset 8 telephone numbers it has been sent.

Input 1 activated: indication that the contact associated with input 1 on the instrument has been closed. This event records when there is no voltage between terminals 32 and 33.

Input 1 deactivated: indication that the contact associated with input 1 on the instrument has been opened. This event records when there is voltage between terminals 32 and 33.

Input 2 activated: indication that the contact associated with input 1 on the instrument has been closed. This event records when there is no voltage between terminals 34 and 35.

Input 2 deactivated: indication that the contact associated with input 1 on the instrument has been opened. This event records when there is voltage between terminals 34 and 35.

GPRS setup modification: (for GSM instruments only). Record of the time when the instrument's GPRS setup was modified.

Alarms setup modification: (for GSM instruments only). Record of the time when the instrument's alarms setup was modified.

8.2.4.- Harmonic statistics file (H24)

A series of values to be subsequently used by the PC's software will be stored in this file. The software will calculate typical deviation, the statistical distribution curve and the effective values at 50%, 95% and 99% of each and every harmonic recorded by the QNA-412.

8.2.5.- Weekly average values file (STP)

This file will save the averaged weekly values for voltage variables (L1, L2 and L3), frequency, flicker (pst and plt) (L1, L2 y L3), harmonic distortion rate (L1, L2, L3 and three-phase), unbalance and the total number of recordings used for calculations. The 0%, 5%, 95% and 100% values may also be obtained individually and as a whole taking into account all recordings, i.e. the whole week or just those

recordings with no voltage events. There is also the option for taking into account incomplete or complete recordings, selected beforehand in the setup (per week).

8.2.6.- Energy file (WAT)

In this file are recorded all the averaged values of energy (active, inductive and capacitive). By default, the period is 15 minutes.

8.2.7.- Setting and operation of the SMS alarms

The QNA-412 (GPRS / GSM model only) may configure up to 8 different alarms. A maximum and minimum limit and a time period may also be set for each alarm. They also may be sent to 4 different telephone numbers.

8.2.8.- Setting and operation of the GPRS

The QNA-412 (GPRS model only) allows information to be sent to an FTP server via GPRS. This means that every X minutes the instrument automatically sends recorded information to an IP address defined by the user. The time period and the IP address are defined by the user. A user name and password supplied by the FTP server administrator to save the information must also be defined. This mode of communication avoids the user having to use a modem to download information, because it is the equipment itself which sends the information to the FTP server. This means that the user only requires an Internet connection to connect with the FTP server and to download the information.

It is recommended that coverage is over 15 for this use.

9.- TECHNICAL SPECIFICATIONS

Power supply:

Supply voltage: Independent from the measuring circuit 100-400 V AC. $\pm 30\%$
90-730 V DC.

Frequency: 50...60 Hz.
Burden: 16 VA – 8 W
Operating temperature: 0°C to 50°C
Storage temperature: -20° to +70°C

Auxiliary power supply:

Battery: Ni-M-H

Independent operating period: 9999 seconds continuous operation

(It is recommended that programming by software does not last for more than 1 hour to increase the life-time of the battery)

Voltage measurement:

Measuring system: 3 wire or 4 wire arrangement (choice by external connection)

Measuring range: 0 to 500 V AC. (phase-to-common)

4-wire system: 0 to 500 V AC. (line-to-neutral). Max: 550 V

0 to 866 V AC. (line-to-line). Max: 952 V

3-wire system: 0 to 500 V AC. (line-to-line). Max: 550 V

Scale switch: Automatic

Other voltages: Via voltage transformers

Frequency : 42.5 – 69 Hz

Current measurement:

Measuring range : ... / 5A (according to current measurement transformers)

Maximum current: 1.2 In

Scale switch: Automatic

Accuracy:

Voltage: 0.1 % of nominal. (Class A according to IEC 61000-4-30)

Current: 0.1 % of nominal. (Class A according to IEC 61000-4-30)

Power: 0.2S according to EN-62053-22

Unbalance: $\pm 0.15\%$ (Class A according to IEC 61000-4-30)

Flicker: 5% according to IEC 61000-4-15 (Class A according to IEC 61000-4-30)

Harmonics: Class I according to IEC 61000-4-7 (Class A according to IEC 61000-4-30)

Measurement conditions to ensure accuracy class:

- Errors due to external voltage transformers not being included.

- Temperature range: 5 to 45 °C.

Measurement range: between 5 % and 100 %.

Internal memory:

Memory size: 4 Mbyte

Memory configuration: rotating

QNA 412 (with default variables)	Default
STD	67 days 8 hours 20 min.
EVE	4665 recordings
EVQ (minimum)	342 recordings
H24	32 days
STP	16 weeks
WAT	3106 recordings

(*) The STD file has been calculated assuming a 10-minute recording period, and the default parameters of the STD file.

Micro-processor:

Sampling frequency: 10.24 k samples/second in each channel (6 channels)
Converter : 16 bit (Sigma delta)

Assembly features:

Casing: according to DIN 43859
Dimensions: according to DIN 43857

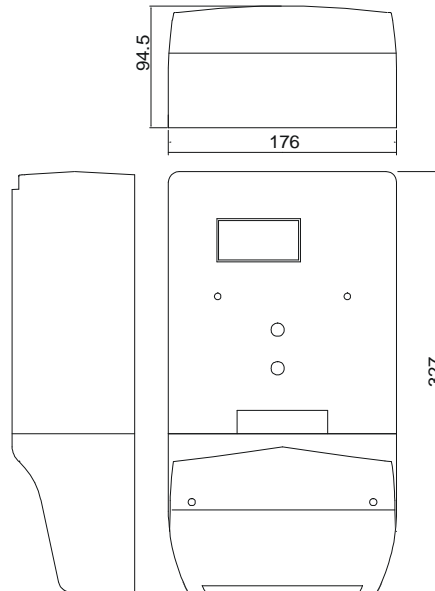

Weight: 2.3 kg

STANDARDS

Quality:	IEC 61000-4-30
Harmonics:	IEC 61000-4-7
Flicker:	IEC 61000-4-15

Other standards:

EN 60664, EN 61010, EN 61036, VDE 110, UL 94

ELECTROMAGNETIC EMISSION

- EN 61000-3-2 (1995), Harmonics
- EN 61000-3-3 (1995), Voltage fluctuations
- EN 50081-2 (1993), Industrial emission
 - EN 55011 (1994): Conducted (EN 55022- Class B)
 - EN 55011 (1994): Radiated (EN 55022 - Class A)

ELECTROMAGNETIC IMMUNITY

- EN 50082-2 (1995), Industrial immunity
 - EN 61000-4-2 (1995), Electrostatic discharge
 - ENV 50140 (1993), EM Radiated field of RF
 - EN 61000-4-4 (1995), EFT burst
 - ENV 50141 (1993), RF common mode
 - EN 61000-4-8 (1995), 50 Hz H-field
 - EN 50082-1 (1997), Residential immunity
 - EN 61000-4-5 (1995), Surges
 - EN 61000-4-11 (1994), Supply voltage interruptions
-

10.- SAFETY CONSIDERATIONS



The user should take into account all installation instructions indicated in the INSTALLATION & STARTUP and TECHNICAL SPECIFICATIONS sections in this manual.

Note that when the instrument is switched on, the terminals may be dangerous when touched and opening or removing parts may access dangerous areas. The analyzer has been designed and tested to meet IEC 348 standard and is factory-shipped in proper operating conditions.

11.- MAINTENANCE

The **QNA-412** does not require any special maintenance. No adjustment, maintenance or repair should be carried out while the instrument is open and switched on. Qualified technicians must carry out these actions when they are necessary.

Before any adjustment, replacement, maintenance or repair, the instrument must be totally disconnected from any power supply source.

If any protection failure is suspected, the instrument must be immediately placed out of service. The instrument's design allows it to be quickly replaced in the event of any breakdown.

The design of the analyzer allows it to be easily replaced in the event of breakdown.

12.- TECHNICAL SERVICE

For any information on the instrument's performance or in the event of breakdown, please contact CIRCUTOR's technical service.

CIRCUTOR S.A. - After-sales service.
Vial Sant Jordi, s/n
08232 - Viladecavalls.
Tel. - (+34) 93 745 29 00
Fax - (+34) 93 745 29 14

E-mail - software@circutor.es

A. Appendix: Communication with the QNA-412 connected to an external modem

One of the most common configurations of the QNA-412 is to connect the analyzer to an external modem.

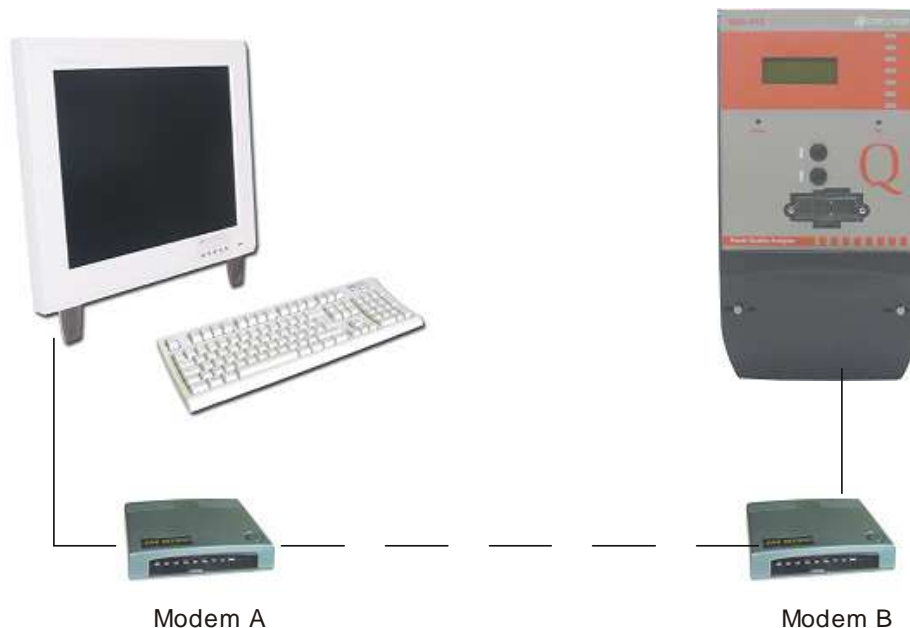

In order to connect and prior to start up, the user must take into account that both modems must have correctly established the communication link. Therefore, the modem making the call and the modem connected to the QNA-412 analyzer must be configured.

This configuration must be carried out using Windows's HyperTerminal program or equivalent. Modem settings must therefore be:

- MODEM A (PC):
 - AT&F** Default configuration
 - AT&D2** Enables DTR operations *Data Terminal Ready*
 - AT&S0** Enables DSR *Data Set Ready*
 - AT&W0** Saves configuration
- MODEM B (QNA-412):
 - AT& F** Default configuration
 - AT&D0** DTR overcontrol
 - AT&K3** Disables data compression
 - AT&R1** The modem ignores the RTS
 - AT&N6** Forces modem baud rate to 9600 bps
 - ATS0=1** Enables modem to answer on the first ring
 - AT& W0** Saves configuration

The above AT commands might vary for different modem models.

Therefore, to ensure the correct configuration, please consult your modem's user manuals.

Communication cable:

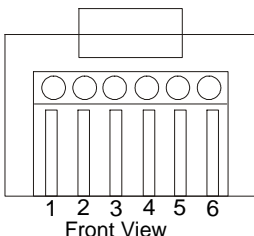
RJ Connector	QNA-412	Modem (DB9)	Modem (DB25)
 <p>Front View</p>	1 – DSR	5–GND	7 – GND
	2 – Rx	2–Rx	3 – Rx
	3 – TX	3–Tx	2 – Tx
	4 – CTS	8–CTS	5 – CTS
	5 –RTS	7–RTS	4 – RTS
	6 – GND	5–GND	7 – GND

Troubleshooting:

Most of problems may be caused by the modem units.

Problem	Solutions
The Modem A does not call.	Check that the used port in the PC matches the one connected in the modem.
	Check the correct performance of the PC and Modem ports using the HyperTerminal program or equivalent.
	Check the modem cabling.
	Check the phone line.
The Modem B does not answer.	Check that the modem is switched on.
	Check the command entry making the modem answer on the first ring (ATS0=1)
The Modem B answers the call but does not receive any response from the analyzer.	Check that the used port is the R1 port.
	Check the QNA-412 communication port configuration. Check that this is set at 9,600 bauds.

Given that it is impossible to ensure compatibility with all modems available on the market, Circutor recommends that the modem type is checked prior to using it.



Local Modem (A) cannot make a call through a telephone switchboard. It must be via a direct line.

B. Appendix: Communications with QNA-412 (RS-485)

QNA-412 can also establish a communication to a PC via an RS-485 network. This connection is done via the QNA-412's RS port.

This kind of communication link is usually used where the analyzer is far away (1200 m, as maximum) from the PC set to be used for data viewing and management.



The following cables must be used for this configuration:

- PC → RS-232 / RS-485 Converter

RS-232		
P.C. (DB9)	P.C. (DB25)	RS-232/485 Converter (DB9)
3-Tx	2-Tx	2-Rx
2-Rx	3-Rx	3-TX
		7-RTS
		8-CTS
5-GND	5-GND	5-GND

- QNA-412 → RS-232 / RS-485 Converter

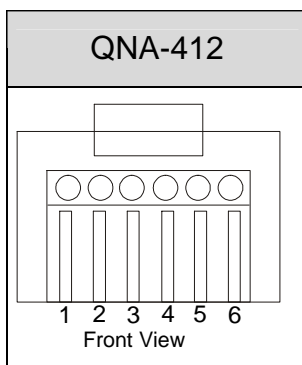

RS-485	
QNA-412	RS-232/485 Converter (DB9)
2-Tx/Rx(-)	2-Tx/Rx (-)
3-Tx/Rx(+)	1-Tx/Rx (+)
6-GND	5-GND

Check that the RS-232 cable is not connected to the PC. This port has priority over the RS-485 port.
The QNA-412 will not be able to communicate via the RS-485 port when connected.

C. Appendix: Communications with QNA-412 using a TCP-IP converter

QNA-412 can also establish a communication to a PC via an ETHERNET network.

For this configuration, CIRCUTOR S.A. can supply a TCP-IP / RS 232-485 (TCP2RS) converter allowing the connection of any device equipped with RS-232 or RS-485 communication to a PC via an ETHERNET network.

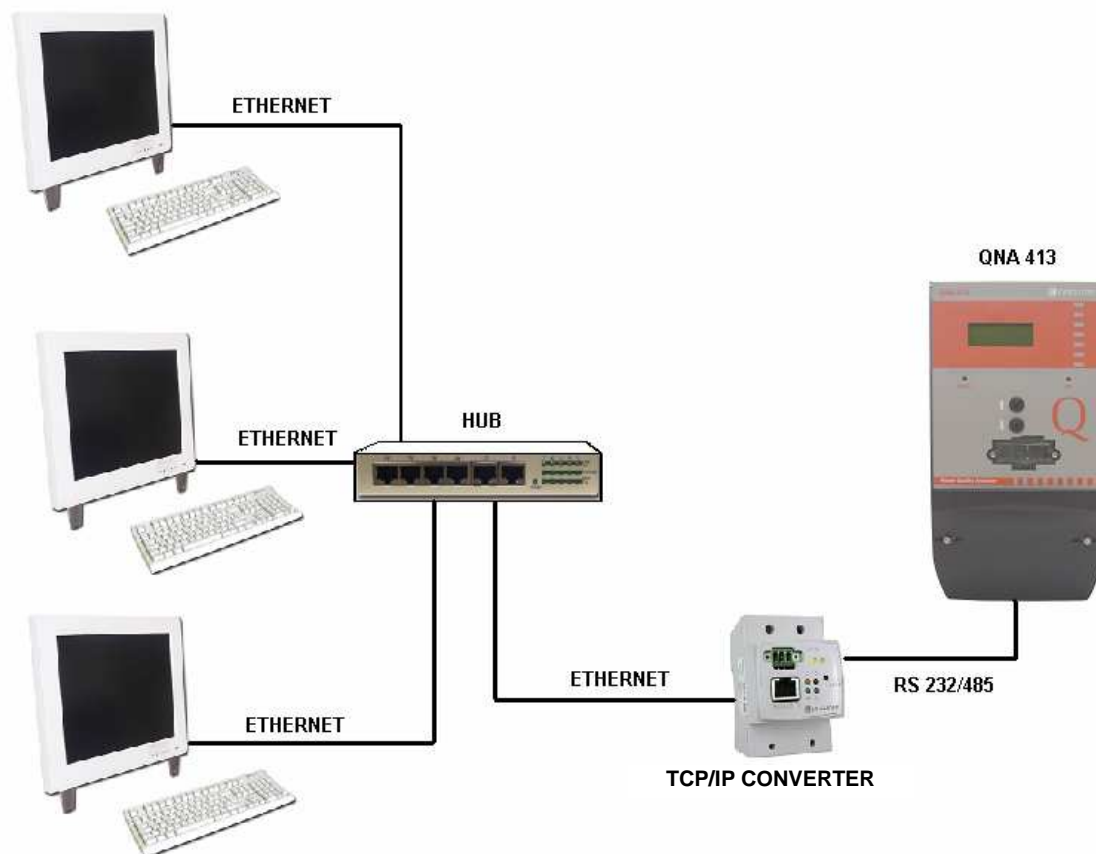

Use the switch on the converter to change the RS-232 signal into an RS-485 signal. Always check that the cable linking the QNA-412 analyzer to the TCP/IP converter matches the Tx/Rx connection.

TCP/IP	
QNA-412	TCP/IP Converter
3	A (+)
2	B (-)
6	S (GND)

D. Appendix: Setting of a QNA-412 ETHERNET Analyzer

The QNA-412 Ethernet, is specifically designed to communicate in Ethernet networks. This system can optimize all RS485 communication bus wiring, thereby also optimizing already created computer infrastructures and facilitating installation.

A CD is supplied with the instrument, which contains different elements:

EDSetup: Setting program for communication parameters.

Com Redirector: Setting program for *virtual ports.

The QNA-412-Ethernet has an RJ Connector45 Ethernet 10Base-T/100Base-TX (self detecting), which connects the device to the Ethernet network (hub or switch), or using a direct cable (braided cable), to the computer which will be a master or will store the application.

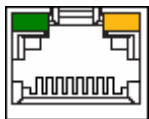

The connection with the master system is via four pair braided Ethernet cable (shielded). One end is connected to the Ethernet QNA-412 device and the other to the network's electronics (hub or switch) on the corporate network.

Where direct connection with a computer or device with Ethernet input is required, the wires in the Ethernet cable must be specially adapted for such communication.

STANDARD ETHERNET CABLE			DIRECT ETHERNET CABLE		
1-Orange	--	1-Orange	1-Orange	--	1-Green
2-Orange/White	--	2-Orange/White	2-Orange/White	--	2-Green/White
3-Green	--	3-Green	3-Green	--	3-Orange
4-Blue	--	4-Blue	4-Blue	--	4-Blue
5-Blue/White	--	5-Blue/White	5-Blue/White	--	5-Blue/White
6-Green/White	--	6-Green/White	6-Green/White	--	6-Orange/White
7-Brown	--	7-Brown	7-Brown	--	7-Brown
8-Brown/White	--	8-Brown/White	8-Brown/White	--	8-Brown/White

NOTE: For communication with the QNA-412, it is essential that the analyzer's speed and the Ethernet module's speed are the same (9600b as a default). Read the following section to set the baud rate: Setting the parameters – TCPSetup.

Setting the parameters – EDSetup

The instrument within the company network (LAN) must be identified, with an assigned IP Address. If the IP address is not known, the network administrator must be contacted to obtain the address.

To assign the IP Address, the EDSetup program must be run and the following screen will appear:



To assign the IP address to the peripheral, the *machine address* must be known (also known as the “MAC ADDRESS”). This machine address appears on the unremoveable label attached to the front of the instrument.

Press *Configure* once the IP Address and the machine’s address have been assigned.

(Detail of setting screen)

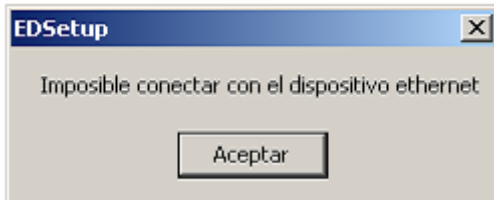

Once the programmable button has been pressed, the software will search for the instrument in the Corporate Network; in the event of a connection problem the device will not be detected and the following screen will appear.

If the instrument has been detected, all communication settings will be displayed:

The options for programming will be displayed on the setting screen:

Web Manager	
Version 3.50:	
Menu	
<input type="button" value="Unit Configuration"/>	
<input type="button" value="Secret Properties"/>	
<input type="button" value="Port Properties"/>	
<input type="button" value="Factory Settings T"/>	
<input type="button" value="Update Settings"/>	
Select Channel	
<input type="button" value="Channel 1"/>	
Selected Channel : 1	
Serial Port Settings	
Serial Protocol	RS232
Speed	9600
Character Size	8
Parity	None
Stopbit	1
Flow Control	CTS/RTS (Hardware)
Connect Mode Settings	
UDP Datagram Mode	Disable
UDP Datagram Type	
<input type="button" value="Change UDP Datagram Type"/>	
Incoming Connection	Accept unconditional
Response	Nothing (quiet)
Startup	No Active Connection Startup
Dedicated Connection	
Remote IP Address	
Remote Port	
Local Port	10001

ETHERNET SETTING

- Serial protocol: RS232
- Speed: 9600
- Character size: 8
- Parity: None
- Stop bit: 1
- Flow Control: CTS/RTS (Hardware)
- UDP Datagram Mode: Disable
- UDP Datagram Type: empty
- Local Port: it's recomendable to write 10001.

Setting of TCP Network Protocol

The port redirection software will be installed (Com Port Redirector), this software allows the PC or master application to use the IP Address for the QNA-412-Ethernet as though it were a computer's physical COM port. This will create a communications tunnel between both peripherals using a transparent connection.

- Start installing and running the Com Port Redirector software from the disk supplied with the instrument. Once it is installed the Com Port Redirector located in *StartRedirector* is run.

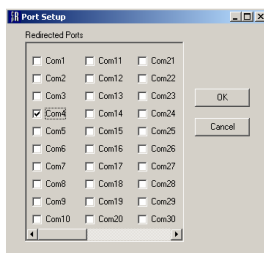

Clicking on *Com Setup* and selecting the virtual series port/s to be created; once created click on "ok" (different virtual ports are created, one per piece of instrument, depending on the number of QNA-412-Ethernet's installed).

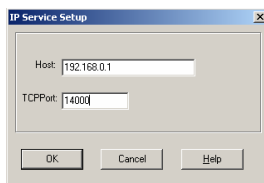

Then the "Add IP" button is clicked for each virtual port created; it must be introduced the IP address of the device in the field *Host*, and then in *TCP Port* it must be introduced the port number that user has introduced in the web page previously. By default this port is 10001.

- To avoid unwanted disconnections or disconnections from the amount of traffic, the communication tunnel reconnection options are enabled from the *Port Settings* option; The following is selected when the setting screen is opened:

- i. *Timeout Reconnect.*
- ii. *Server Reconnect*
- iii. *Raw Mode*

- After setting this last option, all information is then saved by clicking the *Save* button. The machine is restarted so that the ports become active. From now on any application operating via series ports will have the virtual ports set in the software available.

Example (Addressing the virtual port address):

COM4 --- IP 192.168.0.1

- After having followed these steps, the virtual ports will automatically open when there is any application that makes use of the computer's series ports, thus making them available to the software.

E. Appendix: Installation and start up of the QNA-412-GSM



Configure the QNA-412 analyzer before inserting the new SIM card.

The GSM line used must be capable of data transmission!!!

First the SIM on the phone line to be used must be configured to enable communication with the **QNA-412** GSM/RS-232's GSM modem.

This action will always be required when a new SIM card is inserted in the **QNA-412** GSM analyzer, regardless of whether it is the first installation or a replacement SIM.

Proceed as follows:

1. With no SIM card inserted:

- 1) Turn on the **QNA-412** analyzer.
- 2) Connect to the **QNA-412** analyzer via the RS-232 serial port using a communication cable.
- 3) Use the PC software to add a **QNA-412** or, for a SIM change, modify the configuration on the existing **QNA-412** analyzer.
- 4) Access the "general parameter" option in the software field, and select the option called "PIN change".

The following screen will be then shown:

Cambio de PIN

Cambio de SIM

PIN antiguo :
[Input field]

PIN nuevo :
[Input field]

Confirmar PIN nuevo :
[Input field]

PUK :
[Input field]

Activar uso de PIN

- 5) Select options "SIM change" and "Enable use of PIN".
- 6) Enter the PIN and PUK numbers for the SIM to be inserted.
- 7) Accept the action and follow the steps shown by the software:

Insert the new SIM card and then remove the RS-232 communication cable from the analyzer.

2. Inserting the SIM card:

- 8) Loosen the screws on the SIM holder cover.

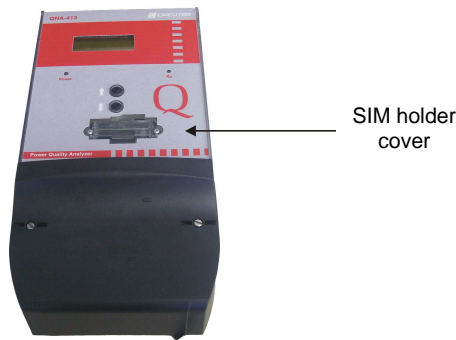

- 9) Carefully pull out the piece.
10) Release the SIM holding lock.

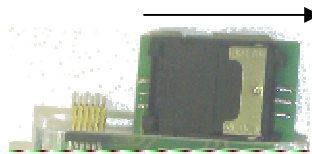

- 11) This position of the lock permits the user to open the holding piece and insert the SIM card.

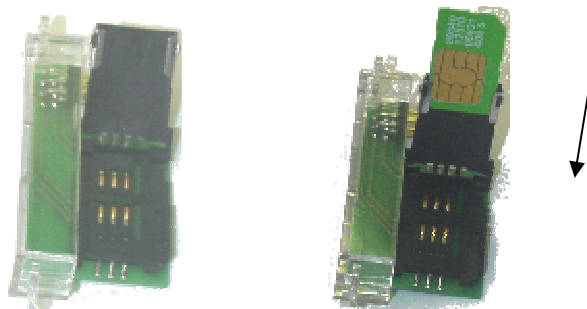

- 12) Close the holding piece and place the lock back into its initial position.
13) Put the SIM holder cover back into the **QNA-412** analyzer.
14) Tighten the cover screws to avoid any possible malfunction of the SIM.

3. With the new card SIM inserted:

- 15) Remove the RS-232 cable from the analyzer.
16) Wait until the PC software issues a warning (About 60 s).
17) Reconnect the RS-232 communication cable to the **QNA-412** analyzer.
18) Check that the PC software notifies the results of the operation. The result may be:
- Successful: the **QNA-412** modem is ready to operate.
 - Error: the SIM card has not been initialized. Check the configuration again, carefully following all steps.

**Upon completion of the installation, ensure that the RS-232 cable is not still connected to the PC.
This connection will prevent the QNA communicating via the GSM modem.**

Note: it is recommended that coverage is a minimum of 15 when using this signal.

F. Appendix: Installation and start up of the QNA-412-GPRS

Steps to be followed when setting the **QNA-412** analyzer so that it sends recorded information via GPRS to an FTP server.

1.- Apply power supply voltage to the **QNA-412** (it is important that when this is done, the RS-232 communications cable is not connected. If it is, then the modem will not start correctly).

2.- Wait for about 3 minutes so that the instrument starts the modem. Press the two keys at the same time until the screen display the message "SIGNAL XX", XX being equal to the value of the existing cover (this may be between 0 and 30). When this message appears, it means that the modem start up process has been correctly carried out.

3.- Connect the RS-232 communications cable to the instrument.

4.- Using the PowerVision software, enter the device's general parameters and then press "GPRS".

5.- The following message will then appear on the screen to allow the GPRS parameters to be changed:

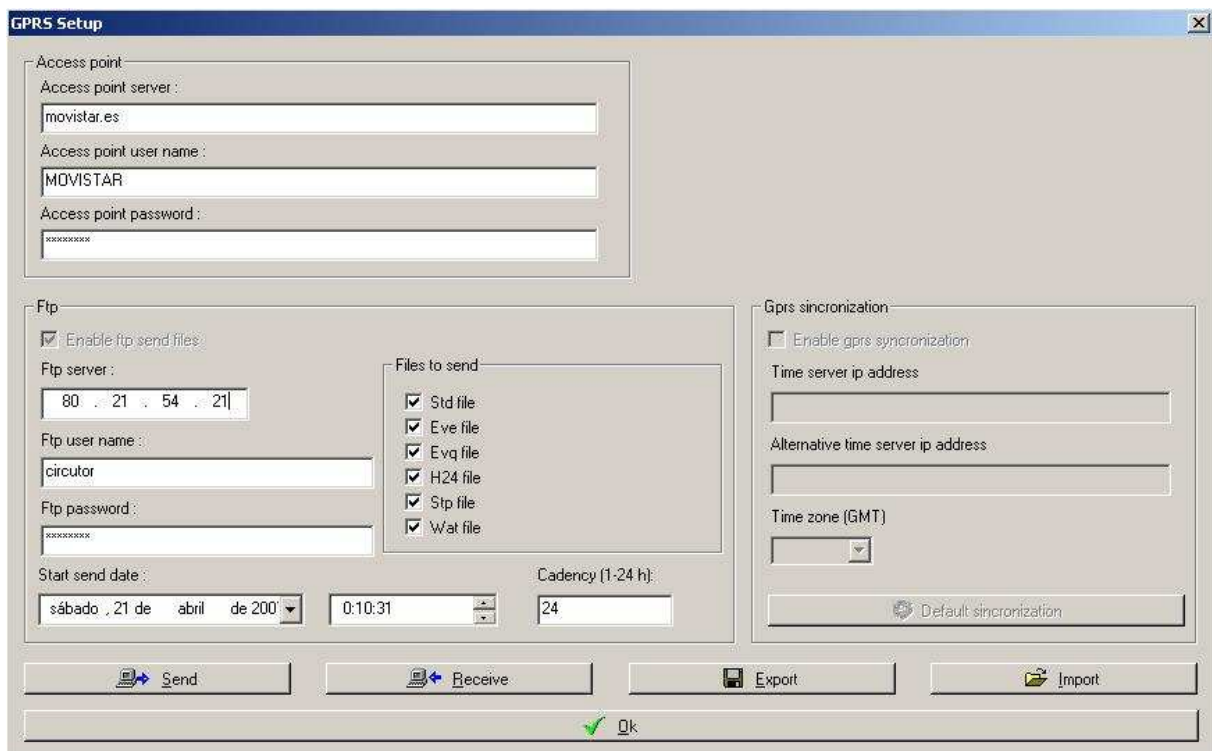

Acces point: This information is provided by the phone operator. For example, Vodafone in Spain has the *Server access point: ac.vodafone.es*, *User name: vodafone* and *Password: vodafone*.

FTP: IP address, user name and password of the FTP server where user wants to download data.

Start download: Is the date when the device will start to send data to the FTP server.

Cadency: Is the period of time that the device will use to send data. It is recommendable to set this time to 24 hours. This means that the device will send data to the FTP server each 24 hours.

Files: Files that user wants to download.

GPRS sincronization: if user wants that QNA will synchronize each time that make a GPRS connection, this option must be activated. The synchronization is made using Time Servers that use time protocol in the port 37. If the user prefers to introduce a different direction instead of the default servers, this is possible, but it is recommended to leave the default configuration. It is important that once this option is activated, the GMT hour should be also activated. Depending on the zone where the device is installed, the GMT hour will be different.

Once all the options will be configured, press the button Send in order to send the new configuration. Now user must follow the instructions that appears in the window in order to finish correctly the startup.

G. Appendix: Setting the SMS Alarms

The equipment may be set so that it sends an SMS message when a preset condition is met.

Follow the steps below to activate and set the alarms.

- Connect the RS-232 communications cable to the instrument or set it to communicate via GSM.
- Using the PowerVision software, enter the device's general parameters and then press "SMS Alarms".
- The following message will then appear on the screen to allow the SMS Alarms parameters to be changed.
- Up to 8 alarms may be enabled at the same time. Once an alarm is enabled, it may be set.

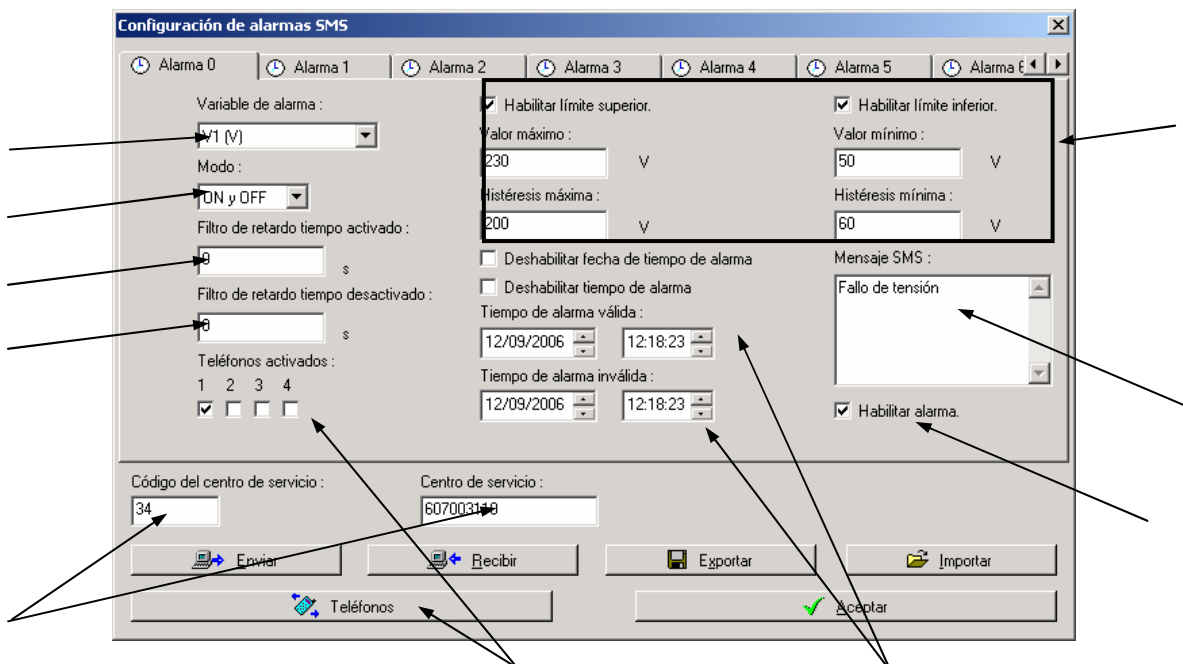

SMS alarms menu (Steps to be followed):

1. Service Centre Telephone:

Country code for service centre (for example, 34 for Spain)
 Contracted company service centre (for example for Vodafone 607003110)

2. Enable Alarm

The different parameters may be set once the alarm is enabled.

3. Select the type of alarm

Drop down menu with the available types of alarm:

Parameters	Variables to be selected	No. of decimals accepted
Voltage	V1, V2, V3, VIII	0
Current	I1, I2, I3, IIII	0
Active power	W1, W2, W3, WIII	0
Capacitive power	vaC1, vaC2, vaC3, vaCIII	0
Inductive power	vaL1, vaL2, vaL3, vaLIII	0
PF	PF1, PF2, PF3, PFIII	2
Voltage THD	VTHD1, VTHD2, VTHD3, VTHDIII	1
Current THD	ITHD1, ITHD2, ITHD3, ITHDIII	1
Unbalance		3
Frequency		2
EVQ	IntV1, IntV2, IntV3, IntVIII, HueV1, HueV2, HueV3, HueVIII SobreV1, SobreV2, SobreV3, SobreVIII	0

Conditions to be taken into account before setting:

- The three-phase power is calculated by adding the three powers.
- The three-phase interruption is activated when the three lines are interrupted and ends when one of these exits this status.
- The three-phase dip and overvoltage appears when one phase enters this status and is deactivated when all phases exits this status.
- The remaining variables produce a three-phase alarm using the three lines.

4. Select the SMS send mode

Possible modes:

- ON** An SMS is sent when an alarm is activated.
OFF An SMS is sent when an alarm is deactivated.
ON and OFF An SMS is sent when an alarm is activated and deactivated.

5. Defining Maximum, Minimum and Hysterisis limits

The maximum and/or minimum values to set off an alarm are now set. The hysteresis value is the margin value to fulfil the alarm condition.

Values entered must be numerical and positive.

Power has to be consumed power.

6. Delay from reaching the alarm level to activating the alarm

Time in which the alarm condition is met. If the day/month/year fields are zero, the time is daily. If these variables are 0, the alarm is always on.

If the selected variable is EVQ, the unit for this variable must be stated in ms.

Note: time and level conditions (limits) have to be met if the alarm is to be activated, taking into account transformer ratios.

7. Delay in which the alarm goes back to OK and is deactivated

If the selected variable is EVQ, the unit for this variable will be 0.

8. Validity period for the alarm

The trip time may be set. The schedule when the alarm is to be active is indicated.

Alarm On time: time when the alarm is to be active.

Alarm Off time: time when the alarm is to end.

Note: If the alarm time date is disabled, the alarm shall be active every day during the preset time slot.
If the alarm time is disabled, the alarm will be active all the time.

9. Alarm message

Received message text.

10. Telephone number(s) to which the SMS is to be sent and their activation

Note: A log is made in the EVE file every time an alarm condition is met or SMS message sent.

FOR EXAMPLE: Example of a voltage alarm setting and the different conditions which may be set.

1. The following parameters are set:

Variable V1

ON and OFF mode

Upper limit: Maximum value: 240, maximum hysteresis: 230

Lower limit: Minimum value: 90, minimum hysteresis: 100

Activated delay time: 5 seconds

Deactivated delay time: 5 seconds

Maximum value	—————	240 V
Maximum hysteresis	-----	230 V
Minimum hysteresis	-----	100 V
Minimum value	—————	90 V

The alarm will be activated under these conditions and an SMS will be sent when, for example, 240 V is exceeded for more than 5 seconds.

The alarm will be deactivated and an SMS sent when V1 is below 230 V for more than 5 seconds.

H. Appendix: QNA-412 measurement method

