



ANALYZER OF THE QUALITY OF ELECTRIC POWER SUPPLY

QNA-413

(Code 771 141 / 771 142)

USER'S MANUAL

(M 981 556 / 02D)

(c) CIRCUTOR S.A.

QNA-413 MANUAL CONTENTS

page

1.-	BASIC INSTRUCTIONS.....	2
1.1.-	Checking the contents of your package.....	2
1.2.-	<i>QNA-413</i> Models	2
1.3.-	Safety warnings	3
1.4.-	Operation instructions.....	3
2.-	MAIN FEATURES	3
2.1.-	Basic features	4
2.2.-	Electrical features	5
3.-	ANALYSIS MODES.....	6
4.-	DATA COLLECTION IN MEMORY (AUTOMATIC MODE)	6
5.-	INSTALLATION & STARTUP	7
5.1.-	Connection terminal.....	8
5.1.1.-	Communication cables for RJ connectors	9
5.2.-	Starting the <i>QNA-413</i> analyzer up	10
5.3.-	Connection diagrams of the <i>QNA-413</i> analyzer.....	11
5.3.1.-	4-wire power systems.....	11
5.3.1.1.-	Direct connection	11
5.3.1.2.-	Through voltage transformers.....	12
5.3.2.-	3-wire power systems.....	13
5.3.2.1.-	Direct connection	13
5.3.2.2.-	Through voltage transformers.....	14
6.-	ON-BOARD BATTERY OF THE <i>QNA-413</i> ANALYZER.....	15
7.-	OPERATION MODE	15
7.1.-	Display and push-buttons	15
7.2.-	Turning the analyzer on	16
7.3.-	Visualization screens	16
8.-	SETTING <i>QNA-413</i> UP	17
8.1.-	Operation setup of the <i>QNA-413</i> analyzer	17
8.1.1.-	Transformation ratios of voltage transformers.....	17
8.1.2.-	Features of the monitored electrical network.....	17
8.1.3.-	Quality parameters.....	18
8.1.4.-	Data to take into account for the periodical data recording process.....	20
8.2.-	Choosing the parameters to be recorded.....	20
8.2.1.-	Standard File (STD)	20
8.2.2.-	Events file (EVQ).....	22
8.2.3.-	Incidents file (EVE).....	23
9.-	TECHNICAL SPECIFICATIONS	24
10.-	SAFETY CONSIDERATIONS	26
11.-	MAINTENANCE	26
12.-	TECHNICAL SERVICE	26
A.-	Appendix: Communications with <i>QNA-413</i> connected to an external modem	27
B.-	Appendix: Communications with <i>QNA-413</i> (RS-485).....	29
C.-	Appendix: Communications with <i>QNA-413</i> by means of TCP-IP converter	30
D.-	Appendix: Installation and startup of <i>QNA-GSM</i>	31
E.-	Appendix: <i>QNA</i> measuring method.....	33

1.- BASIC INSTRUCTIONS

This manual is aimed to familiarize the user with the operation of the power supply quality analyzer model **QNA-413** in order to get the best from its features.

QNA-413 is an analyzer specifically developed for the supervision of the quality of electric power supply, which has been built with components incorporating the most advanced technology in microelectronics, and offer benchtop features for the market in terms of measuring and recording of electrical magnitudes in industrial power supply networks.

You are kindly requested to **carefully read this manual before connecting and powering the analyzer** in order to avoid irreversible damage which might be caused by an improper utilization.

1.1.- Checking the contents of your package

After receiving the analyzer, please check the following points:

- a) The delivered material meets your order specifications.
- b) After unpacking, check that the instrument has not been damaged in transit.
- c) The standard set includes the following items:
 - 1 RS-232 communication cable (female RJ-DB9).
 - 1 **QNA-413** User's manual
 - 1 CD with the program for PC and user's guide
 - 1 GSM antenna (only for the GSM model).

1.2.- *QNA-413* Models



Code	Model
771 141	<i>QNA-413 RS485/RS232</i>
771 142	<i>QNA-413 GSM Free (SIM not included)</i>

1.3.- Safety warnings

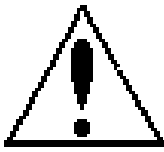

The manual you hold in your hands contains information and warnings about the **QNA-413** analyzer that the user should respect in order to guarantee a proper operation of all the instrument functions and keep its safety conditions.

If the instrument is not used as manufacturer's specifications, the protection of the instrument can be damaged.

When any protection failure is suspected to exist (for example, it presents external visible damages), the instrument must be immediately powered OFF. In this case contact a qualified technical service.

1.4.- Operation instructions

QNA-413 is a programmable instrument, so offering diverse operation modes which can be selected from the available programming menus.

Please, before initiating works with **QNA-413**, thoughtfully read the paragraphs involving **INSTALLATION & STARTUP AND SETTING QNA-413 UP**, in order to select the most suitable operation mode for your requirements.

Note that with the instrument powered on, the terminals could be dangerous to touching, and cover opening actions or elements removal may allow the access to dangerous parts. Therefore, the instrument must not be used until this is completely installed.

2.- MAIN FEATURES

QNA-413 is an analyzer expressly developed for the supervision of the quality of electric power supply as per IEC 61000-4-30 standard.

- Harmonic measurement as per IEC 61000-4-7
- Flicker measurement as per IEC 61000-4-15
- High protection level against severe electrical conditions:
 - Wide range of both supply and measuring voltages.
 - High protection level against overvoltage and transient events.
- Connection to either 3 or 4-wire distribution systems.
- Wide voltage supply range: 63 – 520 V a.c.
- Inner battery which permits the instrument to go on recording works even in case of supply voltage loss.
- 2 Mbytes inner memory for saving all parameters measured by the **QNA-413** analyzer.
- Communication via GSM / RS-232 / RS-485 (according to the model).
- Mounted inside a self-extinguishable case. Dimensions and fixing points according to DIN 43857.

2.1.- Basic features

The **QNA-413** series analyzer is an instrument specially designed for the analysis of the electric power quality as per IEC 61000-4-30 standard.

The analyzer only provides voltage inputs (isolated by means of transformers).

Its external design according to DIN 43857 standard makes it to be an ideal device to be placed inside any energy meter central board.

Moreover, the great variety of available models makes *QNA-413* suitable for any situation and communication mode.

The inner battery of the instrument assures the continuity of the measuring process by the *QNA-413* analyzer in case of any supply voltage loss event (short or long-term line interruption).

QNA-413 is equipped with three A.C. voltage inputs which permit a simultaneous measurement of the **voltage** from all three phases, together with the **frequency**, in any power system.

To accomplish with the analysis of the quality of the electric power supply as per IEC 61000-4-30, **QNA-413 uses a DSP** to analyze all cycles from all three voltage phases to detect the occurrence of any event (voltage dip, voltage swell, interruption). Besides, **the harmonic and flicker calculation as per IEC61000-4-7 and 61000-4-15**, respectively, is also completed.

QNA-413 analyzers are equipped with an **2 Mbytes on-board memory** for the collection of quality parameters as well as events.

The different information recorded by **QNA-413** into its on-board memory is distributed between four file types:

- *.STD files: This file contains all values which are periodically recorded (voltage, frequency, flicker, voltage harmonic distortion, harmonic content, unbalance).
- *.EVE files: File which contains all incidents referred to the **QNA-413** itself (file readout, setup modification, memory erasure, power supply on/off, battery on/off...).
- *.EVQ: This file contains all events observed in the electric power supply (voltage dips, voltage swells, interruptions) together with some supplementary information about these events (instant of the event occurrence, maximum/minimum voltage, average voltage, previous voltage to the event).
- *.H24: This file contains the required data to obtain a statistical analysis of the harmonic evolution along one day.

2.2.- Electrical features

The application of **QNA-413** as a recording instrument for the evaluation of the quality of the electrical power supply implies the need that this analyzer must deliver a high protection degree against severe electrical conditions:

- High-energy varistors for the absorption of surges in order to avoid possible costly repairs.
- Noise filters in voltage and current inputs to assure reliable measurements even under most adverse operation conditions.
- Power supply: transformers with an extra power dissipation and insulation.
- Power supply by built-in battery to assure a voltage supply to the *QNA-413* analyzer in case of voltage loss failure.
- Insulation transformers to guarantee the proper insulation of inputs.

3.- ANALYSIS MODES

QNA-413 series analyzers can perform under different operation modes according to the previous setting.

Most remarkable operation settings are these following:

- Measurement and collection in memory of main power quality parameters (voltage values, flicker, harmonics and unbalance).
- Setting of a voltage threshold to define diverse event occurrences (voltage sags, voltage swells and interruptions). Also an optional setting of a hysteresis value for each individual threshold.
- **QNA-413** can perform **quality analysis** either over 3-wire or 4-wire distribution systems. In accordance to the choice, all quality measurement will be referred to the line-to-neutral or line-to-line voltage.
- **QNA-413** can also be used to execute measurements through **voltage measuring transformers**.

4.- DATA COLLECTION IN MEMORY (AUTOMATIC MODE)

QNA-413 is equipped with an internal clock for both date and time that permits the automatic data recording process in memory to be set up.

So, the different information recorded by **QNA-413** into its on-board memory is distributed between four independent memory blocks, one block for each file type:

- *.STD files: This file contains all values which are periodically recorded (voltage, frequency, voltage harmonic distortion, harmonic content and unbalance).
- *.EVE files: File which contains all incidents referred to the **QNA-413** itself (file readout, setup modification, memory erasure, power supply on/off, battery on/off...).
- *.EVQ: This file contains all events observed in the electric power supply (voltage dips, voltage swells, interruptions) together with some supplementary information about these events (instant of the event occurrence, maximum/minimum voltage, average voltage, previous voltage to the event).
- *.H24: This file contains the required data to obtain a statistical analysis of the harmonic evolution along one day.

QNA-413 is equipped with an on-board **rotary memory** for data collection; which means that once this memory is full, new values overwrite oldest ones. Therefore, if no data is wanted to be lost, data must be retrieved from the memory before oldest values will be overwritten.

5.- INSTALLATION & STARTUP



The manual you hold in your hands contains information and warnings that the user should respect in order to guarantee a proper operation of all the instrument functions and keep its safety conditions.

If the instrument is not used as manufacturer's specifications, the protection of the instrument can be damaged. Notice that with the instrument powered on, the terminals could be dangerous to touching and cover opening actions or elements removal may allow the access to dangerous parts.

When any protection failure is suspected to exist (for example, it presents external visible damages), the instrument must be immediately powered OFF. In this case contact a qualified technical service.

5.1.- Connection terminal

	Terminal No.	Terminal description
	Upper connection terminal	
	21	Measurement VL1
	22	Common L1
	23	Measurement VL2
	24	Common L2
	25	Measurement VL3
	26	Common L3
	27	Not used
	28	Ground
	29	Not used
	30	Not used
	31	Not used
	32	Not used
	33	Not used
	34	Not used
35	Not used	
	Lower connection terminal	
	1	Not used
	2	Not used
	3	Not used
	4	Not used
	5	Not used
	6	Not used
	7	Not used
	8	Not used
	9	Supply voltage input
	10	Supply voltage input
	R1	RS-232
	R2	RS-485 / GSM Antenna (According to the model)

The **QNA-413** analyzer can be indistinctly installed in a three-phase distribution line with neutral conductor (4 wires) or without neutral conductor (3 wires). The measuring process only depends on the connection mode and the analyzer configuration

The connection of the earthing terminal is essential to assure the efficiency of *QNA-413* protective elements.

5.1.1.- Communication cables for RJ connectors

For each **QNA-413** model the use of the RJ connection is different. Thus:

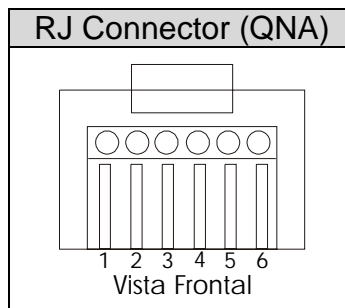
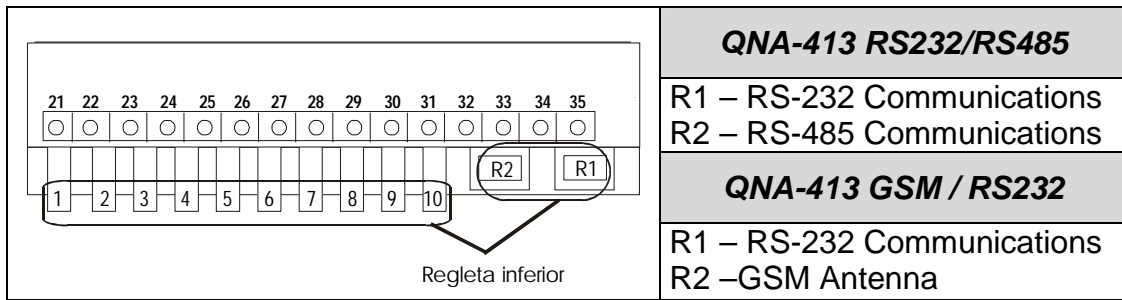

The most usual lay-outs of the **QNA-413** communication cables are following exposed:

- RS-232 connection to PC or to external modem:

QNA-413	PC		External Modem	
	DB9	DB25	DB9	DB25
1-DSR	5-GND	7-GND	5-GND	7 - GND
2-Rx	3-Tx	2-Tx	2-Rx	3 - Rx
3-TX	2-Rx	3-Rx	3-Tx	2 - Tx
4-CTS	7-RTS	4-RTS	8-CTS	5 - CTS
5-RTS	8-CTS	5-CTS	7-RTS	4 - RTS
6-GND	5-GND	7-GND	5-GND	7 - GND

- RS-485:

QNA-413	RS-232/485 (DB9) Converter
2-Tx/Rx(-)	2-Tx/Rx (-)
3-Tx/Rx(+)	1-Tx/Rx (+)
6-GND	5-GND

To establish a communication with a QNA-413-GSM through a mobile phone, the RS-232 communication cables must always be disconnected. If the RS-232 is connected, then the modem operation is completely disabled.

5.2.- Starting the *QNA-413* analyzer up

Before powering the analyzer on please check following points:

1) Mains supply voltage:

Voltage: 63 – 520 V a.c.

Frequency: 50... 60 Hz.

2) Ground terminal: The ground terminal of the analyzer must be connected to earth. The lack of this connection implies the inefficiency of some instrument protective elements.

3) Maximum voltage in the voltage measuring circuit: 500 V c.a. between phase and common:

4-wire arrangement 500 V a.c. line-to-neutral. / 866 V a.c. line-to-line.

3-wire arrangement: 500 V a.c. line-to-line.

3) Analyzer burden: 16 VA

4) Working conditions:

- Working temperature range: 0 °C to 50 °C.
- Working humidity: 25% to 75 % RH.

5) Safety: Designed to meet protection class III as per EN 61010.

Points to check during the installation process:

6) Verify that the ground terminal of **QNA-413** is connected to the earth in order to avoid possible interferences over the analyzer to occur. If this ground terminal is not connected, then the efficiency of the **QNA-413** protection elements would be reduced.

7) Verify the **QNA-413** setup.

Points to consider:

A symptom of a wrong analyzer installation or configuration is the visualization of **blinking voltage values in display**. Possible causes might be:

- The analyzer detects an event: This can mean a real event occurrence in the network, or a wrong rated voltage setting since the set value does not matches the network actual voltage.
- If, moreover, **the unbalance screen shows dashes**, this means an incorrect phase sequence arrangement.

5.3.- Connection diagrams of the QNA-413 analyzer

5.3.1.- 4-wire power systems

5.3.1.1.- Direct connection

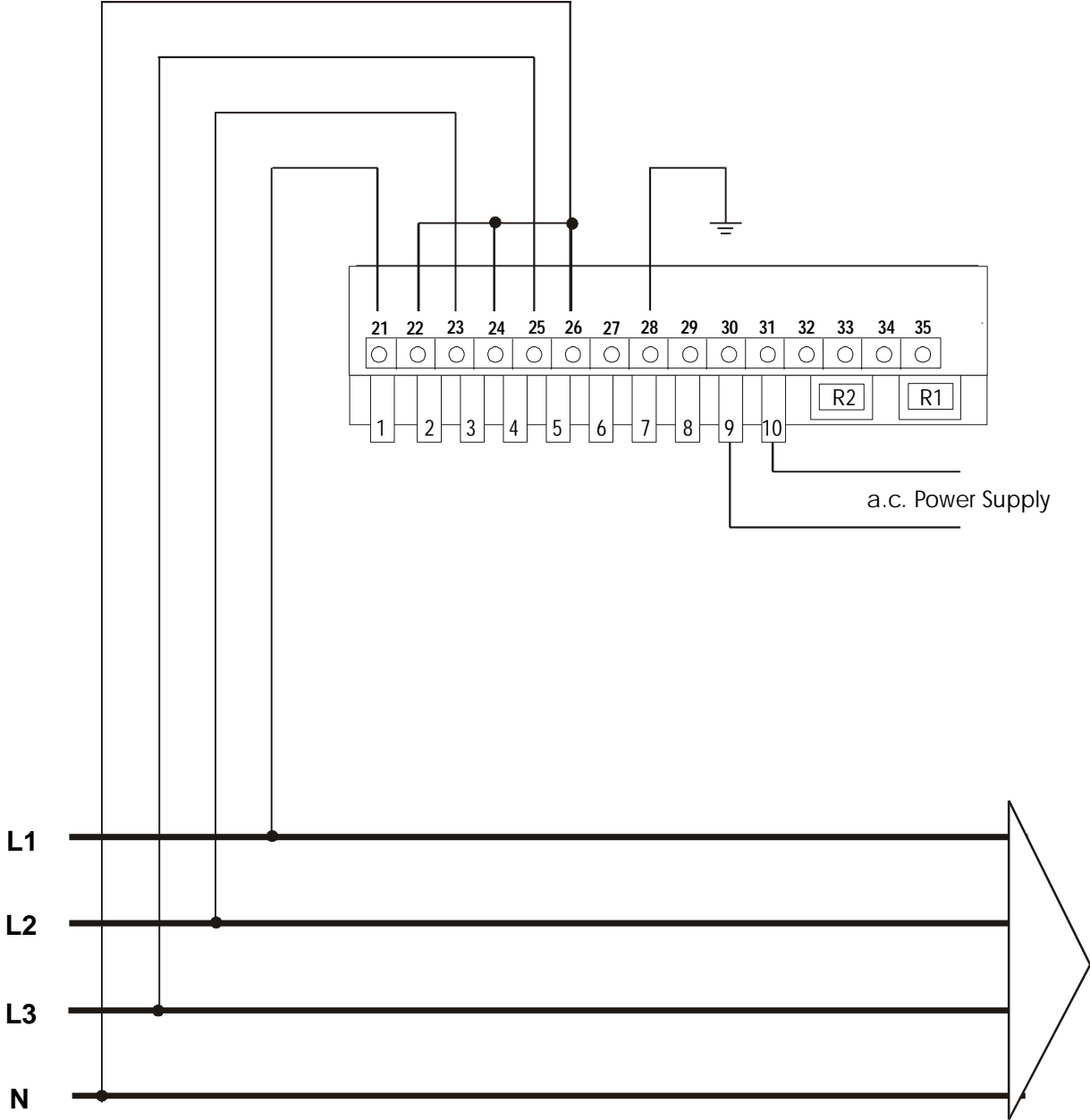

5.3.1.2.- Through voltage transformers

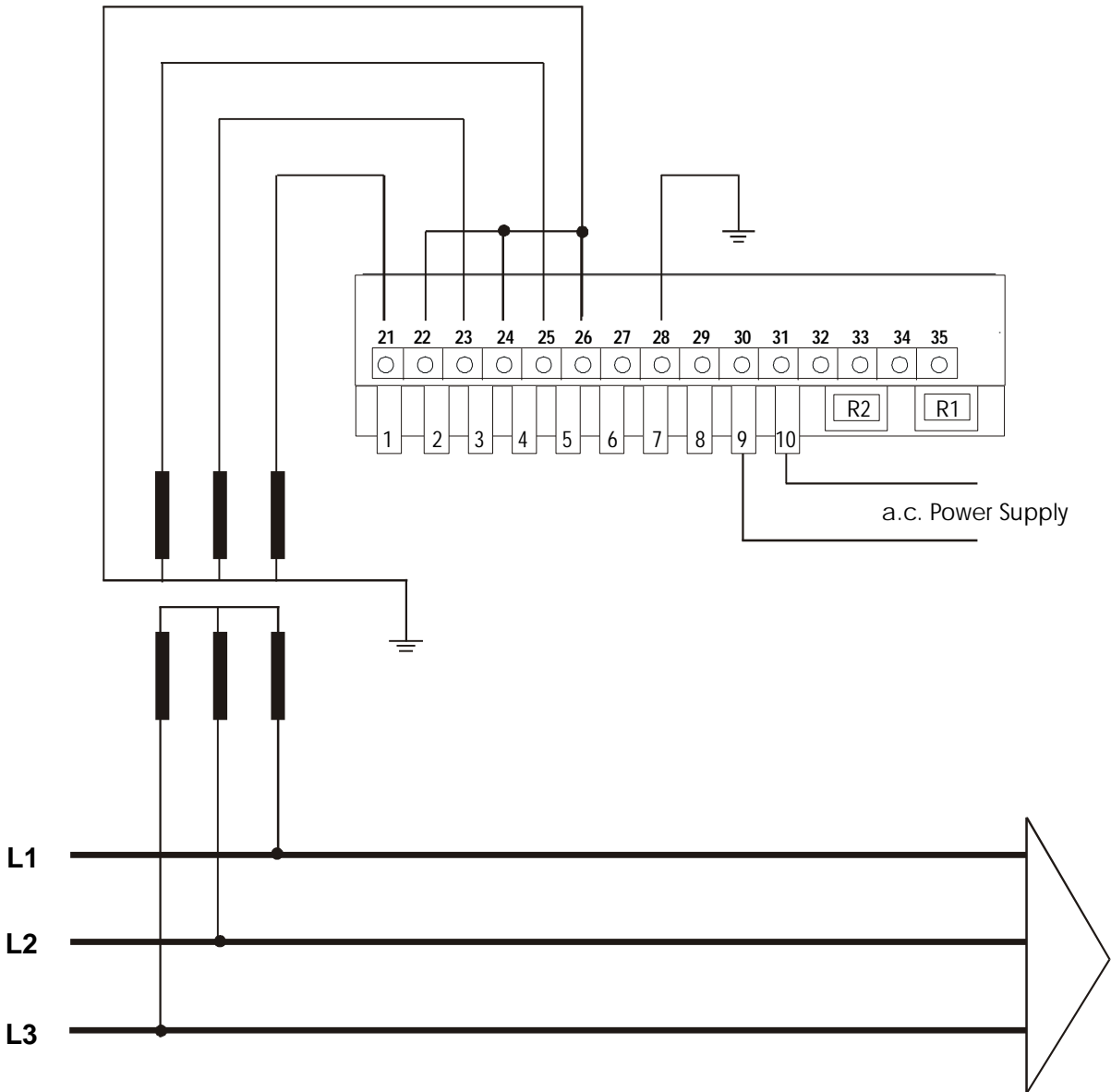

5.3.2.- 3-wire power systems

5.3.2.1.- Direct connection

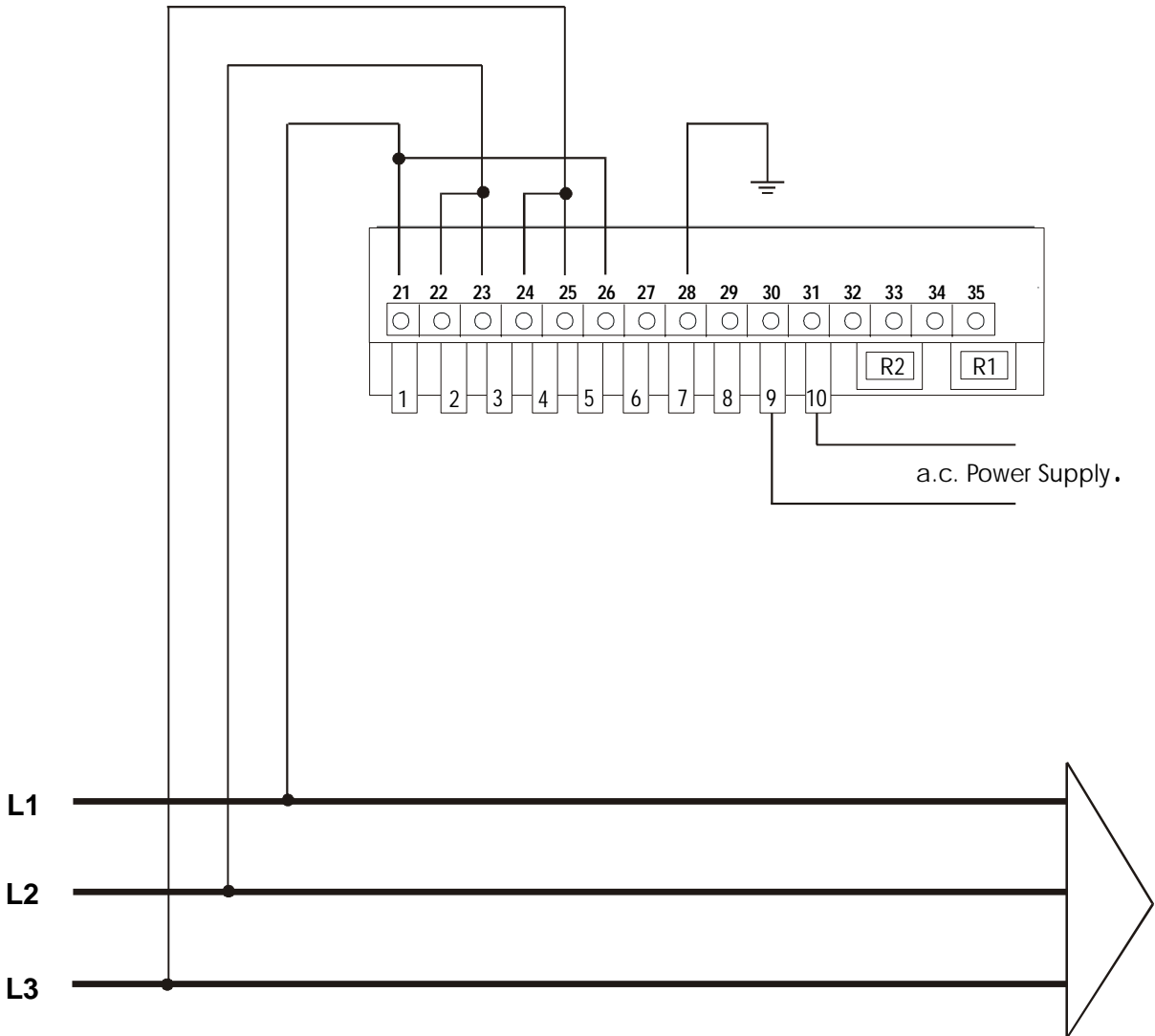

5.3.2.2.- Through voltage transformers

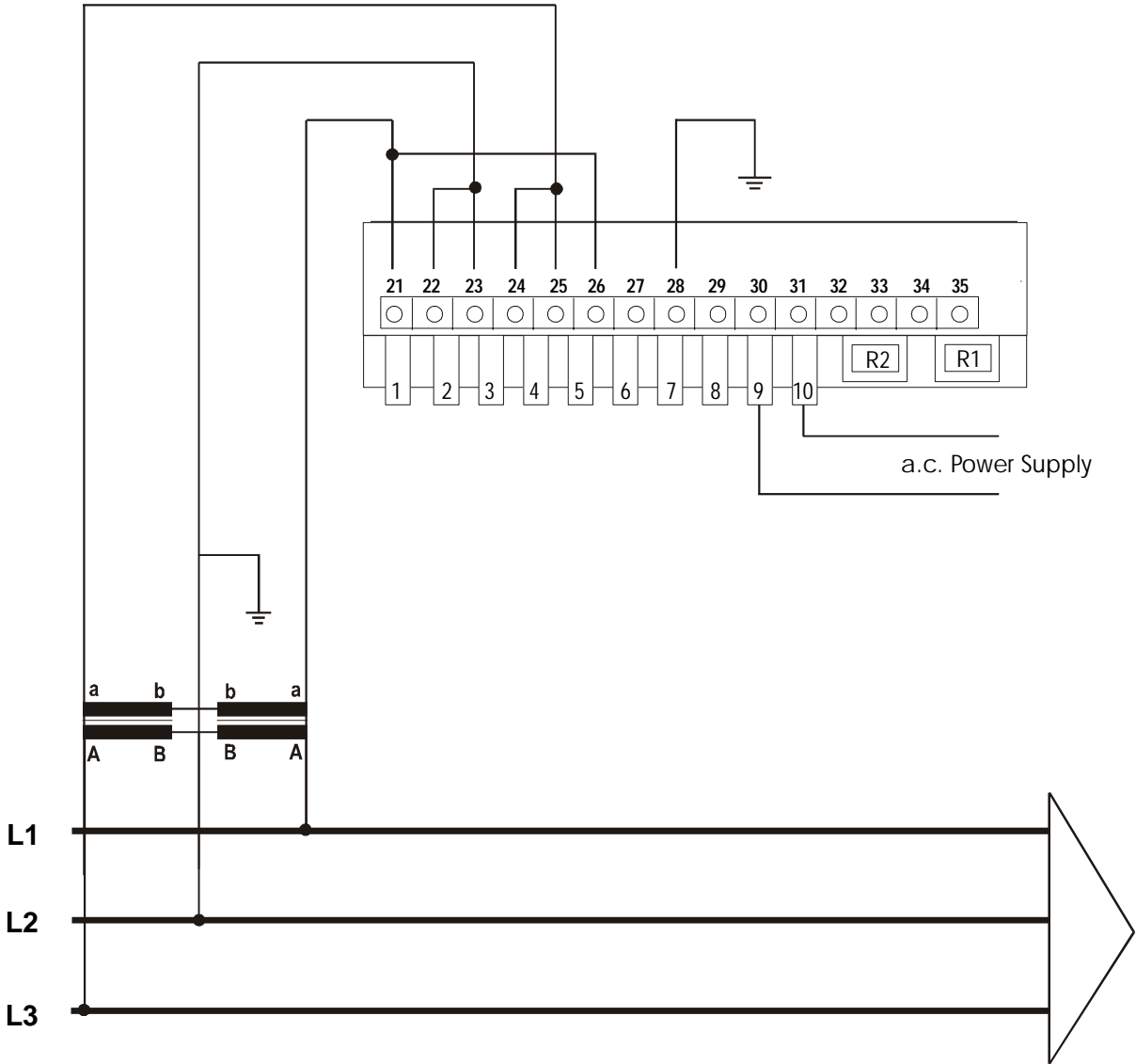

6.- ON-BOARD BATTERY OF THE *QNA-413* ANALYZER

The analyzer has an inner battery to assure the power supply of the analyzer when any event occurs. This battery permits to keep the analyzer continuously energized during 2-4 hours in case of lack of voltage supply from the mains. This period of time of operation after a voltage supply loss is user-programmable in order to economize the battery charge and to assure the detection of possible intermittent voltage interruptions.

The warranty of a 2-4 hour operation period is essential to assure the proper detection and recording of multiple and long-term voltage interruptions.

**When the analyzer is connected to the mains,
the battery is self-recharging.**

The *QNA-413* analyzer is equipped with an **intelligent energy charging system**. This means that the instrument continuously checks in an automatic way the status of the battery, thus the charging process stops when the battery is at its maximum charge level and, therefore, the life span of the battery is increased.



7.- OPERATION MODE

7.1.- Display and push-buttons

QNA-413 is equipped with a display to view, by means of diverse push-buttons, all the information being measured by the analyzer.



The function of each push-button in the *QNA-413* analyzer is:



-  (Next screen): The next visualization screen is accessed.
-  (Previous screen): The previous visualization screen is accessed.

7.2.- Turning the analyzer on

When the **QNA-413** is turn on, a first screen, with the analyzer identification, appears up:



After some seconds, the display will show a screen where you can view the three voltages measured by **QNA-413** at each phase.

Use the  and  push-buttons to move along every different available visualization screens.



7.3.- Visualization screens

The available visualization screens in the QNA-413 analyzer are following enumerated:

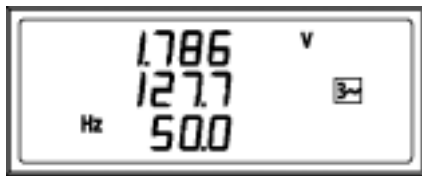

 Voltage measured in the network



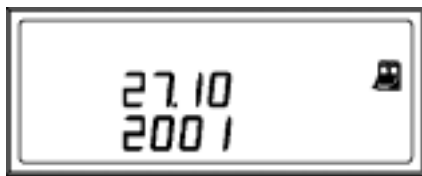

 Unbalance rate
 Asymmetry rate
 Frequency

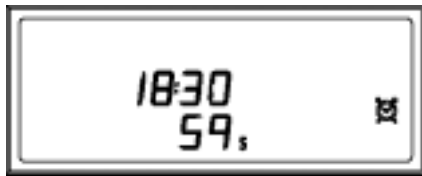

Date
 Day / month
 Year



Clock
 Hour / Minutes
 Seconds

Remarks

A symptom of a wrong analyzer installation or configuration is the visualization of **blinking voltage values in display**. Possible causes might be:

- The analyzer detects an event: This can mean a real event occurrence in the network, or a wrong rated voltage setting since the set value does not matches the network actual voltage.
- If, moreover, **the unbalance screen shows dashes**, this means an incorrect phase sequence arrangement.

8.- SETTING *QNA-413* UP

Any setup action over the *QNA-413* analyzer must be always executed through a PC set

The ***QNA-413*** analyzer performance will depend on the user-configuration of the instrument. To accomplish this configuration, two different setup sections can be distinguished:

- Operation Setup: To define the ***QNA-413*** analyzer operation mode.
- File Setup: To define the data collection procedure of the ***QNA-413*** analyzer into the internal memory. (In this model, all parameters are fixed and cannot be user-changed).

8.1.- Operation setup of the *QNA-413* analyzer

Points to be user-defined are following:

8.1.1.- Transformation ratios of voltage transformers

The ***QNA-413*** analyzer can make measurements through voltage transformers.

- **Voltage primary value / Voltage secondary value:** Set the transformation ratio of voltage transformers used for measuring purposes. In case of a direct measurement of the voltage (no voltage transformer used) then just set 1/1.

8.1.2.- Features of the monitored electrical network

- **Rated voltage:** The rated voltage of the power system to be monitored by the ***QNA-413*** analyzer. In case of a 3-wire arrangement, then the line-to-line voltage must be set (ex. 400 V~), and for a 4-wire arrangement, then the line-to-neutral voltage must be set (ex. 230 V~). If any voltage measuring transformer is used, then the rated voltage to be set must be referred to the secondary side (ex. 63.5 V~). A right configuration of this point is essential since permits setting the limits for the analysis of the electric power supply quality.
- **Rated frequency:** The rated frequency of the power system to be monitored by the ***QNA-413*** analyzer. This parameter is necessary for the calculation of the signal RMS value in extreme quality networks.
- **4 Wires / 3 Wires:** The ***QNA-413*** analyzer must be set according to the distribution system to be monitored, whether with neutral conductor (4 wires) or without neutral conductor (3 wires). A proper setting of this point is essential to assure a right detection of event occurrences. This choice must also match the external connection arrangement.

8.1.3.- Quality parameters

For the determination of the electric power supply quality, the voltage levels that define the event occurrence must be previously set.

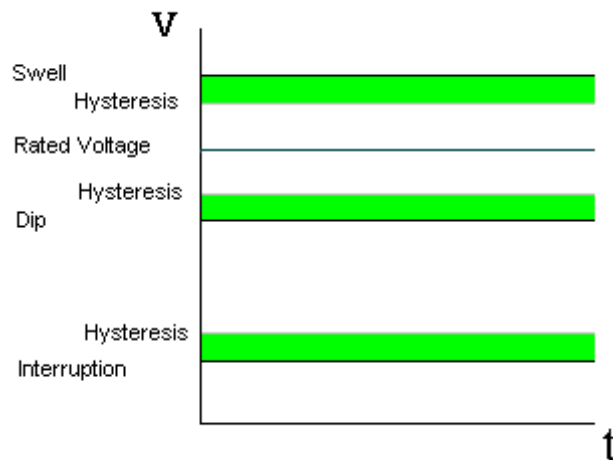

Hence, following points must be user-defined:

- **% of voltage swell threshold:** The detection of a voltage swell depends on the value set in this point (% of the rated voltage). Every semicycle whose RMS value is over the defined limit value is stated to be a voltage swell. A record will be saved into the events file (EVQ) every time that this limit value is exceeded, with the indication of the phase, the maximum voltage value detected, the voltage average value, the voltage value previous to the event, and the duration of the voltage swell event.
- **Voltage swell hysteresis:** A voltage swell hysteresis value can be defined to set a different value for the voltage swell event starting and ending point. Thus, a voltage swell event starts when the voltage swell threshold is exceeded, and ends when the voltage value is under the value defined by the subtraction of the voltage swell hysteresis value from the voltage swell threshold.
- **% of voltage dip threshold:** The detection of a voltage dip depends on the value set in this point (% of the rated voltage). Every semicycle whose RMS value is below the defined limit value is stated to be a voltage dip. A record will be saved into the events file (EVQ) every time this limit value is exceeded, with the indication of the minimum voltage value detected, the voltage average value and the duration of the voltage dip event.
- **Voltage dip hysteresis:** A voltage dip hysteresis value can be defined to set a different value for the voltage dip event starting and ending point. Thus, a voltage dip event starts when the voltage dip threshold is not reached, and ends when the voltage value is over the value defined by the addition of the voltage dip hysteresis value to the voltage dip threshold.
- **% of interruption threshold:** The detection of an interruption depends on the value set in this point (% of the rated voltage). Every semicycle whose RMS value is below the defined limit value is stated to be an interruption. A record will be saved into the events file (EVQ) every time this limit value is exceeded, with the indication of the minimum voltage value detected, the voltage average value and the duration of the interruption event.

- **Interruption hysteresis:** An interruption hysteresis value can be defined to set a different value for the interruption event starting and ending point. Thus, an interruption event starts when the interruption threshold is not reached, and ends when the voltage value is over the value defined by the addition of the interruption hysteresis value to the interruption threshold.
- **Recording capacity of the STD file.** Part of the memory allocated for this file saving, expressed in days. This is a not modifiable value, which will depend on the recording period and the memory allotment defined for the other files.
- **Number of registers of the EVE file.** Part of the memory allocated for the incidences file saving, expressed in the number of incidences.
- **Number of registers of the EVQ file.** Part of the memory allocated for the events file saving, expressed in the number of events.
- **H24 file size (in kbytes):** Indication of the H24 file size.

		Default	Maximum	Minimum
Recording capacity of the STD file. (*)		34 days 5 hours (Calculated value – Not settable)		
Number of registers	EVE file.	1365	170480	682
	EVQ file	2554	47581	2042
H24 file size (in kbytes):		264 (33 days)	1230 (153 days)	8 (1 day)

(*) The STD file has been calculated assuming a 10-minute recording period, and the number of registers of EVE, EVQ and H24 files with the default values.

- **Example:**
 - Recording capacity of the STD file: 51 days 7 hours**
 - Number of registers of the EVE file: 1365**
 - Number of registers of the EVQ file: 2554**
 - Size of the H24 file (in kb): 264**
 - Recording period: 15 Minutes**

8.1.4.- Data to take into account for the periodical data recording process

Some discrete points permits the user to exactly define the information to be used for the register calculation procedure .

So, the user can define:

- **Description of the measuring site:** Just an identification field to be filled by the user.
- **Remark:** Just an informative field to be filled by the user.
- **Recording period:** (only affects over the .STD file). The recording period of the integrated values. The recording period is, by default, set to 10 minutes, but this value is user-settable from 1 minute to 2 hours.
- **Integration of 10-cycle blocks with events (all excepts for the voltage):** (only affects over the .STD file). While the analyzer is calculating the voltage, flicker, harmonic averages, an event might happen (voltage swell, dip, ...). **QNA-413** permits the addition (or not) into the integration of the 10-cycle block that has suffered the event. If this option is disabled ("No"), then the 10-cycle block would be only added to the voltage average.
- **Integration of 10-cycle blocks with events (voltage):** (only affects over the .STD file). While the analyzer is calculating the voltage average, an event might happen (voltage swell, dip, ...). **QNA-413** permits the addition (or not) into the integration of the 10-cycle block (this can be one or more, depending on the event duration) that has suffered the event. If this option is disabled ("No"), then the 10-cycle block would be neglected, and, therefore, it would not be added to the integration of this periodical register. This option does not affect over the rest of parameters.
- **Date type:** (only affects over the .STD file). Permits the user to select date/time to be saved together with each register. This date can be the register initial or ending one.
- **Time for battery auto-power off:** The user can set the time to be waited before the **QNA-413** battery auto-power off in case of supply voltage loss, in order to economize the battery charge and to assure the detection of possible intermittent voltage interruptions. A common value is about 15-30 min.

8.2.- Choosing the parameters to be recorded

QNA-413 saves into its on-board memory records of all quality parameters. The different information recorded by **QNA-413** is distributed between three file types:

8.2.1.- Standard File (STD)

The standard file (STD) is used to store all parameters which are periodically recorded.

Over the user-defined recording period, following electric parameters will be saved into the memory:

➤ **Voltage:**

- **Average:** voltage average value over the recording period.

➤ **Flicker:**

- **Pst:** *QNA-413* saves the Flicker value (Pst) obtained over the recording period. The Plt value will be calculated by the data analysis software in the PC.

➤ **Harmonics:**

- **Harmonic distortion:** *QNA-413* will calculate and record into memory the value of the voltage average harmonic distortion detected in the monitored power system.
- **Harmonic content:** *QNA-413* will calculate and record into memory the average value of the individual harmonic distortion rate of each voltage harmonic in the monitored power system (up to the 40th harmonic) (harmonic content of each 10-cycle blocks which have been integrated over a recording period).

➤ **Unbalance:**

- **Asymmetry rate:** ratio of the homopolar voltage to the direct voltage.
- **Unbalance rate:** ratio of the inverse voltage to the direct voltage.

8.2.2.- Events file (EVQ)

The analyzer also records an events file that contains information on any event detected in the monitored power system. Following data is saved about each event:

Event date: Indication of the instant of the event occurrence. This value is obtained with an accuracy of one cycle.

Type of event: Indication of the event type, that is, a voltage dip, a voltage swell or an interruption. These events are defined in accordance to the **QNA-413** setup. (See Section ¡Error! No se encuentra el origen de la referencia.). The type of event also identifies the phase this event has happened over.

Duration of the event: Period of time in milliseconds that the event has lasted.

Average voltage of the event: The voltage average RMS $\frac{1}{2}$ (*) value over the event happening period.

Maximum/minimum voltage of the event: In case of an interruption or voltage dip event, the voltage minimum RMS $\frac{1}{2}$ (*) value obtained during the event happening period. In case of a voltage swell even, the maximum values will be recorded.

Previous voltage to the event: The voltage RMS $\frac{1}{2}$ (*) value before the event occurrence is recorded.

(*) RMS $\frac{1}{2}$ value: RMS value of a complete cycle, refreshed every semi-cycle.

8.2.3.- Incidents file (EVE)

All incidents referred to the **QNA-413** itself are automatically saved into this file, with the indication of both the occurrence moment and type. Following incidents can be detected and recorded by **QNA-413**:

Battery OFF: Indication of the moment when **QNA-413** stopped its operation. This moment depends on the value set by the user as the period of time of operation after a voltage supply loss.

Auxiliary power supply ON: Indication of the moment when the **QNA-413** analyzer has been connected to an external power supply.

Auxiliary power supply OFF: Indication of the moment when the external power supply of the **QNA-413** analyzer has been interrupted. The analyzer is supplied from this moment by the on-board battery.

Setup modification: Record of the moment when any modification of the instrument setup is done.

Memory formatting: Indication of the moment when the user has decided the **QNA-413** internal memory to be formatted.

Forced memory formatting: The **QNA-413** internal memory will be automatically formatted if any error in this internal memory is detected.

Delete a file: Indication of the moment when the user has deleted any file from the **QNA-413** internal memory. If the first data shown by the .EVE file is the indication that a file has been delete, then this means that the deleted file was the events file.

Time change: Indication of any change of the date or time of the analyzer's on-board clock. The record of this event type is quite important, since when illogical intervals of time between two successive readouts are observed, this might be due to a change of the time of the on-board clock.

Mechanical characteristics:

Case: As per DIN 43859

Dimensions: As per DIN 43857

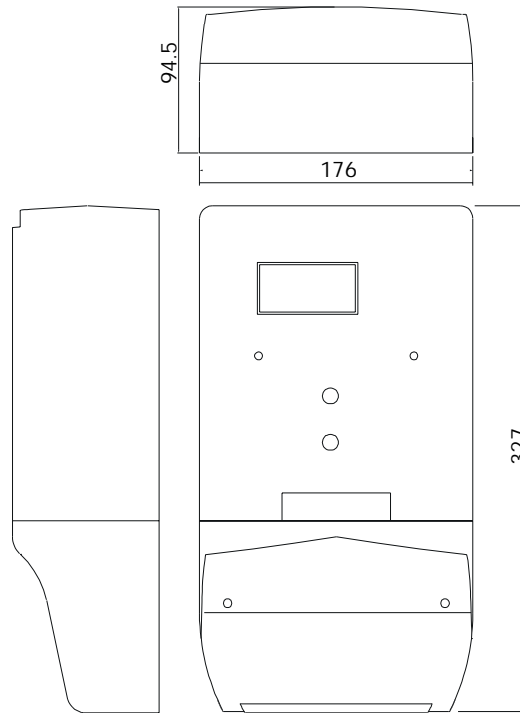

Weight: 2.3 kg

STANDARDS

Quality : IEC 61000-4-30

Harmonics: IEC 61000-4-7

Flicker: IEC 61000-4-15

Other standards:

EN 60664, EN 61010, EN 61036, VDE 110, UL 94

EM EMISSION

- EN 61000-3-2 (1995), Harmonics.
- EN 61000-3-3 (1995), Voltage fluctuations.
- EN 50081-2 (1993), Industrial emission.
- EN 55011 (1994): Conducted (EN 55022 - Class B).
- EN 55011 (1994): Radiated (EN 55022 - Class A).

EM IMMUNITY

- EN 50082-2 (1995), industrial immunity.
 - EN 61000-4-2 (1995), ESD.
 - ENV 50140 (1993), EM Radiated field of RF.
 - EN 61000-4-4 (1995), EFT burst.
 - ENV 50141 (1993), RF common mode.
 - EN 61000-4-8 (1995), 50 Hz H-field
 - EN 50082-1 (1997), Residential immunity.
 - EN 61000-4-5 (1995), Surges.
 - EN 61000-4-11 (1994), Supply voltage interruptions.
-

10.- SAFETY CONSIDERATIONS



The user should take into account all installation instructions indicated in sections INSTALLATION & STARTUP and TECHNICAL SPECIFICATIONS of this manual.

Notice that with the instrument powered on, the terminals could be dangerous to touching, and cover opening or elements removal actions may allow the access to dangerous parts. The analyzer has been designed and tested to meet IEC 348 standard and is factory-shipped in proper operating conditions.

11.- MAINTENANCE

QNA-413 does not require any special maintenance. No adjustment, maintenance or repairing action should be done over the instrument open and powered and, should those actions are essential, high-qualified operators must perform them.

Before any adjustment, replacement, maintenance or repairing operation is carried out, the instrument must be totally disconnected from any power supply source.

When any protection failure is suspected to exist, the instrument must be immediately put out of service. The instrument's design allows a quick replacement in case of any failure.

The design of the analyzer permits its quick replacement in case of failure.

12.- TECHNICAL SERVICE

For any inquiry about the instrument performance or If any failure happens, please contact to CIRCUTOR's technical service.

CIRCUTOR S.A. - After-sales service
Vial Sant Jordi, s/n
08232 - Viladecavalls (BARCELONA - SPAIN)
Tel - + 34 93 745 29 00
fax - + 34 93 745 29 14

E-mail : central@circutor.es

A.- Appendix: Communications with *QNA-413* connected to an external modem

One of the most common arrangements of *QNA-413* is the connection of the analyzer to an external modem.

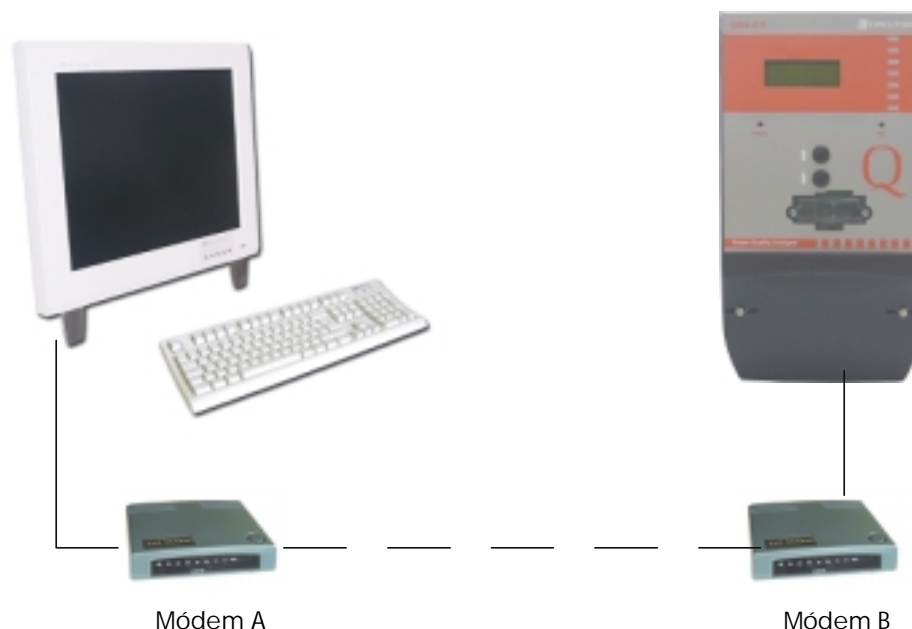

To carry this connection out, and before a definitive starting up, the user must take into account that both modems must correctly establish the communication link. Thus, a simple configuration of either the modem that makes the call and the modem that is connected to the *QNA-413* analyzer must be completed.

These configuration actions must be completed by means of the Windows's HyperTerminal program or an equivalent one. So, modem settings must be:

- MODEM A (PC):
 - AT&F** Default configuration
 - AT&D2** Enables DTR operations *Data Terminal Ready*
 - AT&S0** Enables DSR *Data Set Ready*
 - AT&W0** Saves configuration
- MODEM B (*QNA-413*):
 - AT& F** Default configuration
 - AT&D0** DTR overcontrol
 - AT&K3** Disables data compression
 - AT&R1** The modem neglects the RTS
 - AT&N6** Forces modem baud rate to 9600 bps
 - ATS0=1** Enables modem to answer when the first ring is received
 - AT& W0** Saves configuration

Above enumerated AT commands might vary for different modem models. Therefore, to assure a right configuration, please consult your modem user's manuals.

Communication cable:

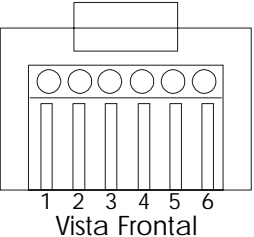
RJ Connector	<i>QNA-413</i>	Modem (DB9)	Modem (DB25)
	1 – DSR	5–GND	7 – GND
	2 – Rx	2–Rx	3 – Rx
	3 – TX	3–Tx	2 – Tx
	4 – CTS	8–CTS	5 – CTS
	5 –RTS	7–RTS	4 – RTS
	6 – GND	5–GND	7 – GND

**Check that the RS-232 cable is not connected to the PC. This port have priority before the GSM.
If connected, then the QNA will not be able to communicate through the GSM port.**

Troubleshooting:

Most of troubles that might appear are caused by the modem units.

Trouble	Solutions
The Modem A does not call.	Check that the used port in the PC matches the one the modem is connected into.
	Check the right performance of the PC and the Modem ports by means of the HyperTerminal program or an equivalent one.
	Check the modem cabling.
	Check the phone line.
The Modem B does not answer.	Check that the modem is turn on.
	Check the introduction of a command to make the modem to answer at the first ring (ATS0=1)
The Modem B answers the call but does not receive any response from the analyzer.	Check that the used port is the R1 port.
	Check the QNA-413 communication port configuration. Check that this is set at 9,600 bauds.
	The RS-232 port is connected to the PC.

B.- Appendix: Communications with *QNA-413* (RS-485)

QNA-413 can also establish a communication to a PC through an RS-485 network. This connection is done through the RS port of ***QNA-413***.

This kind of communication link is mostly used for those cases where the analyzer is far away (1,200 m, as maximum) from the PC set to be used for data viewing and management.

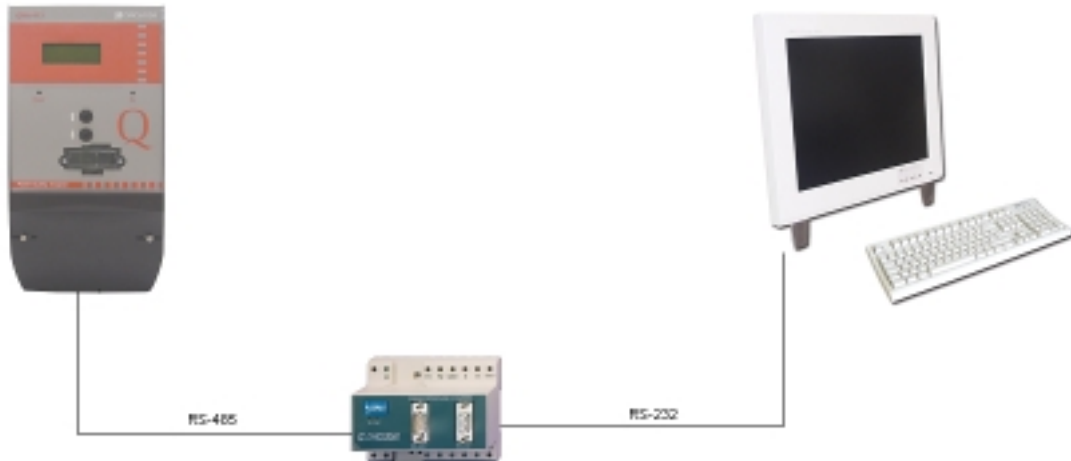

To set this arrangement, following cables must be utilized:

- PC → RS-232 / RS-485 Converter

RS-232		
PC (DB9)	PC (DB25)	RS-232/485 Converter (DB9)
3-Tx	2-Tx	2-Rx
2-Rx	3-Rx	3-TX
		7-RTS
		8-CTS
5-GND	5-GND	5-GND

- *QNA-413* → RS-232 / RS-485 Converter

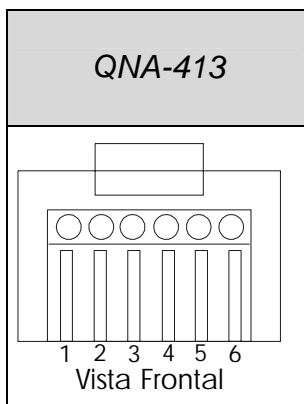

RS-485	
<i>QNA-413</i>	RS-232/485 Converter (DB9)
2-Tx/Rx(-)	2-Tx/Rx (-)
3-Tx/Rx(+)	1-Tx/Rx (+)
6-GND	5-GND

Check that the RS-232 cable is not connected to the PC. This port have priority before the RS-485 port.
If connected, then the QNA will not be able to communicate through the RS-485 port.

C.- Appendix: Communications with *QNA-413* by means of TCP-IP converter

QNA-413 can also establish a communication to a PC through an ETHERNET network.

To set this arrangement, CIRCUTOR S.A. can supply a TCP-IP / RS 232-485 converter that enables the connection of any device equipped with RS-232 or RS-485 communication ability to a PC set through an ETHERNET network.

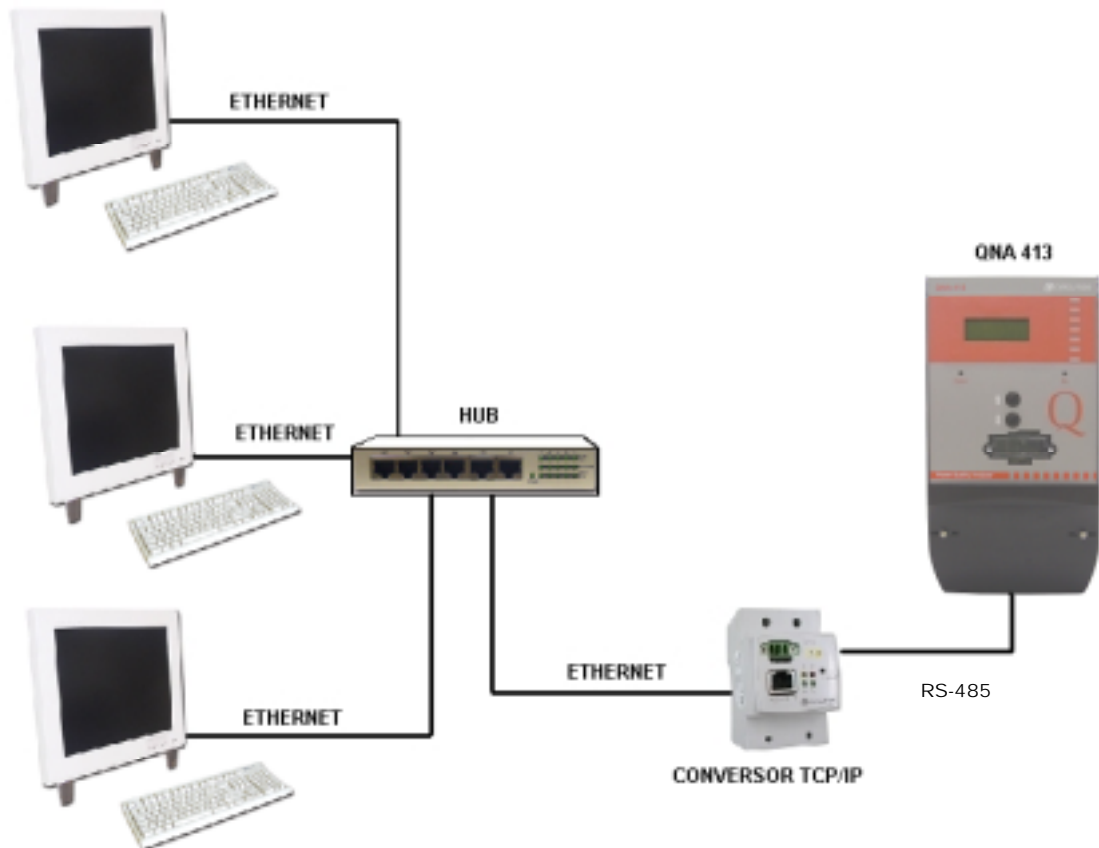

To set the converter in order to turn the signal into RS-232 or RS-485 mode the user just must use a switch placed in the converter. Always check that the cable that links the ***QNA 413*** analyzer to the TCP/IP converter respects the Tx/Rx connection.

TCP/IP	
<i>QNA 413</i>	TCP/IP Converter
3	A (+)
2	B (-)
6	S (GND)

D.- Appendix: Installation and startup of QNA-GSM.



Before inserting the new card SIM, set the QNA-412 analyzer up

To enable the communication with the GSM modem of QNA-412 GSM/RS-232, the SIM of the phone line to be used must firstly be configured.

This action will be required always that a new card SIM is inserted in the QNA GSM analyzer, regardless it is the first installation or a replacement of the SIM.

So, proceed as follows:

1. With no card SIM inserted:

- 1) Turn the QNA analyzer on.
- 2) Connect to the QNA analyzer through the RS-232 serial port by means of the communication cable.
- 3) Use the PC software to add a QNA or, in case of a SIM change, then modify the configuration of the already existing QNA analyzer.
- 4) Access the option “general parameter” in the software field, and select the option called “PIN change”.

The below screen will be then shown:

- 5) Select options “SIM change” and “Enable use of PIN”
- 6) Introduce the PIN and PUK numbers of the SIM to be inserted.
- 7) Accept the operation and follow the steps that the software indicates:
 - Insert the new card SIM and then remove the RS-232 communication cable from the analyzer.

2. How to insert the card SIM?

- 8) Loose the screws from the cover of the SIM holder.

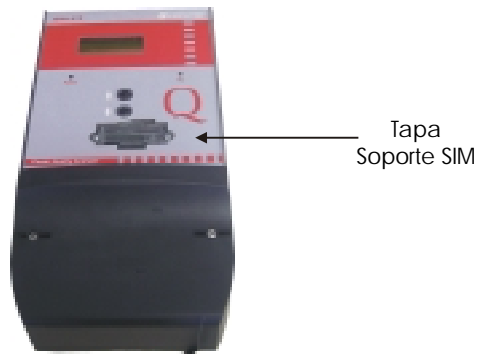

- 9) Carefully pull the piece out.
10) Release the SIM holding lock.

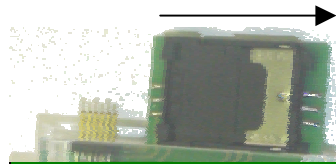

- 11) This position of the lock permits the user to open the holding piece and insert the card SIM.

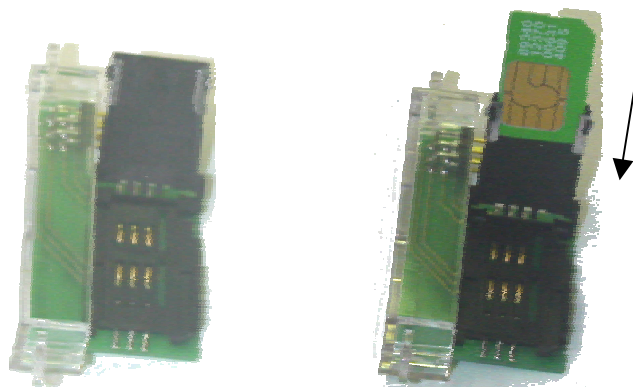

- 12) Close the holding piece and place the lock back to its initial position.
13) Put the cover of the SIM holder back in the QNA analyzer.
14) Tighten the cover screws to avoid possible malfunctioning of the SIM.

3. With the new card SIM inserted:

- 15) Remove the RS-232 cable from the analyzer.
16) Wait until the PC software warns (About 60 s)
17) Connect the RS-232 communication cable back into the QNA analyzer.
18) Check that the PC software notifies the operation result. The result can be:
- Succeeded: The QNA modem is ready for its operation.
 - Error: The SIM card has not been initialized. Check again the configuration, following thoughtfully all enumerated steps.

E.- Appendix: QNA measuring method

