

# **USER'S GUIDE**



**DH-96 A.C./D.C**

# INDEX

<b>Chapter 1</b>		<b>Page</b>	<b>Chapter 4</b>
<b>Product description</b>	<b>Información del aparato</b>		
Introduction		2-3	
Technical specifications		4-5	
Safety warnings		6	
<b>Chapter 2</b>		<b>Capítulo 2</b>	
<b>Installation and startup</b>	<b>Instalación y puesta en marcha</b>		
Dimensions		7	
Wiring diagrams		8	
Pluggin cards		9	
<b>Chapter 3</b>		<b>Capítulo 3</b>	
<b>Setting up the instrument</b>	<b>Programación</b>		
Keyboard functions		10	
Configuration		11	
Instruments for d.c. signal		12-13	
Instruments for a.c. signal		14-15	
<b>Chapter 4</b>		<b>Capítulo 4</b>	
<b>Application notes</b>	<b>Anexos y definiciones</b>		
Adjustment of instruments for d.c.		16-18	
Adjustment of non-linear equations		19	
Adjustment of instruments for a.c.		20-22	
Modification of the auxiliary voltage		23	
Safety options		24	

Index

## Introduction

Digital indicators of the DH96 Series have been designed to offer a wide range of specifications and features in a compact and heavy duty device, thus allowing their operation within any industrial environment meeting all the requirements and standards currently established.

These indicators are based on a microprocessor that regularly takes samples from the measuring signals, and provides true R.M.S. measurements after a calculation process, which is nowadays essential to guarantee a proper accuracy when monitoring distorting waves generally present at installations with a great quantity of industrial equipment that provoke an important distortion in the power system such as d.c. drives, rectifier units, electronic reactors, etc.

The easy and intuitive setup process of digital indicators enables the user to quickly familiarize with their operation mode, for the modification of diverse configuration options with no need to consult this manual again.

Instruments of the DH96 Series have been tested in laboratories and checked at industrial environments, and have successfully passed the most rigorous tests involving ambient conditions, electrical noises, electromagnetic disturbances, vibrations, etc....

### Expansion options

Indicator's standard features can be expanded with the use of optional pluggable cards. Available expansion cards are:

- Cards equipped with two alarm relay outputs
- Cards equipped with four alarm relay outputs
- Cards equipped with analog output
- Cards equipped with RS-485 serial communication output (MODBUS Protocol, RTU mode)

■ The instrument is equipped with a connector for the card input.

### **Cards equipped with two alarm relay outputs & Cards equipped with four alarm relay outputs**

- Trip due to maximum or minimum conditions
- Trip delay user-configurable between 1 and 9999 s
- Reset delay user-configurable between 1 and 9999 s
- Hysteresis user-configurable between 1 to 9999 points
- Optional trip latch
- Optional operation mode with failure safety function

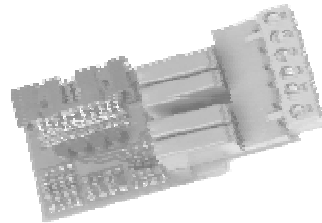
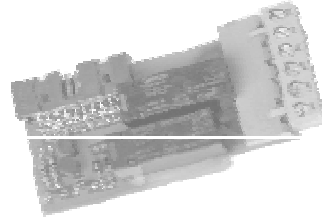

### **Cards equipped with analog output**

- User-selectable output: 4...20 mA or 0...20 mA
- User-configurable range output



### **Cards equipped with RS-485 or RS-232 serial communication output**

- MODBUS communication protocol
- User-configurable instrument direction
- User-selectable baud rate: 1200, 4800, 9600 or 19200 bits/s
- User-selectable parity: Even, Odd or None
- User-selectable stop bits: 1 or 2

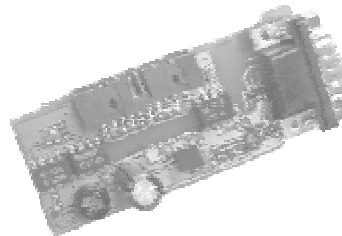

## Technical specifications

	<b>Auxiliary supply</b>	<b>Alimentación auxiliar</b>
	Rated value:	115 V or 230 V (-15%, +20%)
	Frequency range:	45 to 65 Hz
	Burden:	4 VA (without optional card) 7 VA (maximun burden)
	<b>Display</b>	<b>Visualizador</b>
	-9999 ... 9999	-9999 ... 9999
	7 segmentos	7 segments
	4 dígitos de 14 mm de altura	14 mm high 4 digits
	Color rojo	Hi-efficacy red colour
	Indicación exceso de escala: "----"	Overrange indication: "----"
	8 leds de indicación	8 indication leds
	Punto decimal programable	Programmable decimal point
	Ciclo de presentación: 500 ms	Data updating time on disp: 500 ms
	<b>Input circuit</b>	<b>Visualizador</b>
	-9999 ... 9999	Meas. system by means of a microp.
	A/D converter resolution d.c.:	12 bits + sign (8192 points conv.)
	Conversion method:	Successive approximations
	Conversion time:	500 $\mu$ s
	Núm. of conversions per sample:	32
	Measurement accuracy:	0,1% $\pm$ 1 digit
	Measurement range:	1,2 rated value
	Voltage overload:	1,5 Un contin. / 3 Un during 10 s
	Current overload:	2 In continuously / 5 In during 5 s
	Voltage burden:	0,001 VA
	Current burden:	0,003 VA
	<b>Analog output</b>	<b>Salida analógica</b>
Product description	Output types:	0 ... 20 mA or 4 ... 20 mA
	Output impedance:	< 500 $\Omega$
	Response time:	< 150 ms
	Ripple - RMS:	< 0,1 %
	Accuracy class:	0,2
	Error specification:	$\pm$ 0,19 % $\pm$ 0,01 %
	Temperature coefficient:	125 ppm / $^{\circ}$ C
	<b>Isolation</b>	<b>Alimentación auxiliar</b>
	Between the input circuit,the measuring circuit and	the output (relays analog, RS485 or RS232)
	Test voltage:	3 kV RMS 50 Hz during 1 min
	Pulse test:	4 kV (1.2 / 50 $\mu$ s)

## Technical specifications

<b>Environmental conditions</b>	<b>Visualizador</b>
Storage temperature:	-40 °C ... + 70 °C
Operation temperature:	-10 °C ... + 65 °C:
<b>Relays characteristics</b>	<b>1 commuted contact</b>
Rated a.c. current:	8 A
Maximun a.c. current:	10 A
Rated voltage:	250 V a.c. 50 Hz
Maximun voltage (VDE 0435):	440 V a.c.
Maximun a.c. resistive load:	2000 VA
Isolation resistance at 500V:	> 10 <sup>4</sup> MΩ
Contact-coil isolation:	6000 V a.c.
Contact-contact isolation:	1000 V a.c.
Mechanical endurance:	> 20 x 10 <sup>6</sup> operations
Electrical endurance:	> 2 x 10 <sup>6</sup> operations at 5A and 35V
<b>Relays characteristics</b>	<b>1 single contact</b>
<b>Rated a.c. current:</b>	<b>5 A</b>
Maximun a.c. current:	5 A
Rated voltage:	250 V a.c.. 50 Hz
Isolation resistance at 500V:	> 1000 MΩ
Contact-coil isolation:	2000 V a.c.. - 1 min
Contact-contact isolation:	1000 V a.c. - 1 min
Mechanical endurance:	> 20 x 10 <sup>6</sup> operations
Electrical endurance:	> 100 x 10 <sup>3</sup> operations
<b>General characteristics</b>	<b>Condiciones ambientales</b>
Dimensions:	96 x 48 x 138 mm
Weight:	550 g
Case material:	Self-exting. ABS, anthracite grey
Protection degree:	Frontal: IP54
:	Case: IP20
	Terminal: IP20
<b>Desing standards</b>	<b>Características generales</b>
D	IEC 1010
	IEC 348
	IEC 664
	IEC 801
	VDE 0110
	VDE 0435
	EN 50081-2
	EN 50082-2

Product description

## Safety warnings

---

**17.3 Information and warning texts**  
The DH96 meets protection class I.

- All indicators are equipped with a grounding terminal
- The case is not dangerous to tactile touching (isolating material)
- Screws of terminals are not accessible for human appendix

This instrument has been designed and tested to meet IEC 348 standard and is factory-shipped in proper conditions. The manual you hold in your hands contains information and warnings that the user should respect in order to guarantee a proper operation of all of the instrument functions and keep its safety conditions.

### 17.3.2 Installation

The instrument is for indoor use. It could be occasionally subjected to temperatures between +75 °C and 10 °C keeping its safety conditions.

The instrument must not be powered and used until its final assembly on the board. Before powering the instrument, its grounding terminal must be connected to a suitable protection conductor.

### 17.3.4 Warning!

Any interruption of the protection conductor, either inside or outside the instrument, or the disconnection of the protection grounding terminal might imply a dangerous situation; therefore, any intentional interruption is totally forbidden.

### 17.3.5 Adjustment, element replacement and repairing actions

With the instrument powered on, the terminals could be dangerous to touching and cover opening actions may allow accessing dangerous parts. Therefore, before any adjustment, replacement, maintenance or repairing operation is carried out, the instrument must be disconnected from any power supply source.

No adjustment, maintenance or repairing operation should be done over the instrument open and powered and, should those are essential, high-qualified operators must perform them.

Check that fuses used for replacing damaged ones match required types and rated currents. The use of improvised fuses or to short-circuit fuse bases is totally avoided.

### 17.3.6 Defects and malfunction

When any protection failure is suspected to exist, the instrument must be immediately put out of service. The protection could be damaged whether:

- You can see damages on the case
- It cannot perform proper measurements
- Storage conditions were not the suitable ones
- Any damage in transit occurred.

# Dimensions

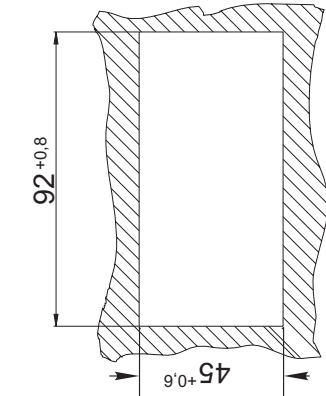
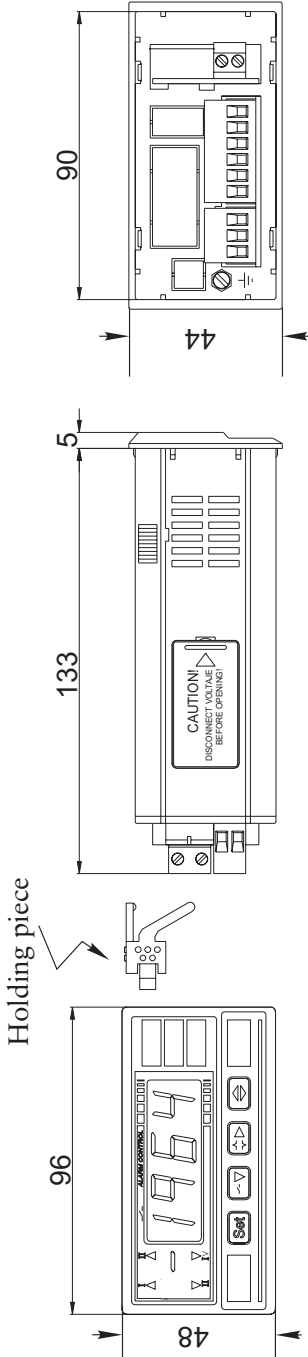

Panel cut-out

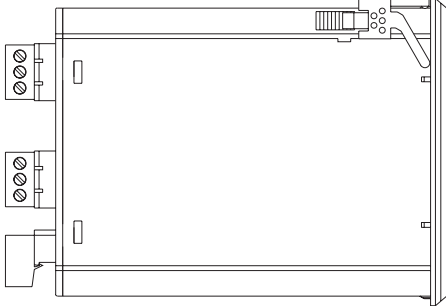

Installation and startup

# Wiring diagrams

## MEASUREMENT

### Voltage input

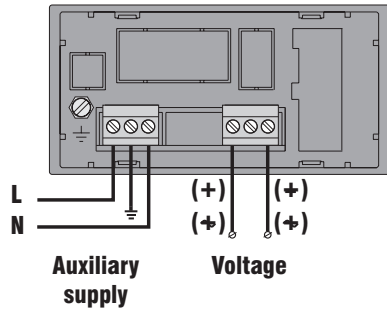

### Current input

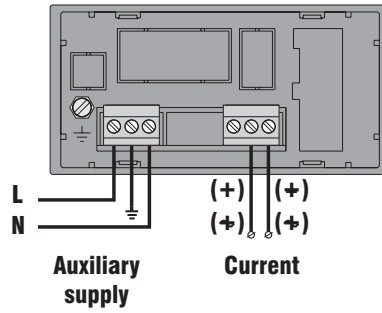

## OPTIONS

### 2 Relays

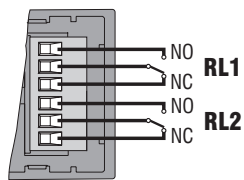

### 4 Relays

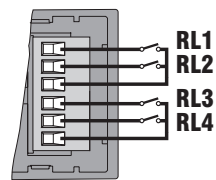

Installation and startup

### Analog output

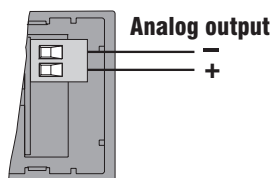

### RS-485 type output

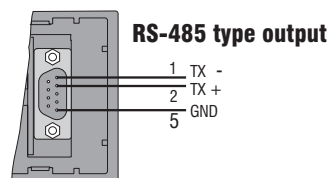

## Plugging cards

**WARNING:** Insure that no incoming wire is connected to the instrument before doing any work on the equipment, since failure to observe this practice can result in equipment damage and even serious injury.

Proceed as below pictures show.

1) Press the case holding piece with a screwdriver or a similar tool in order to release the base from the rest of the case.

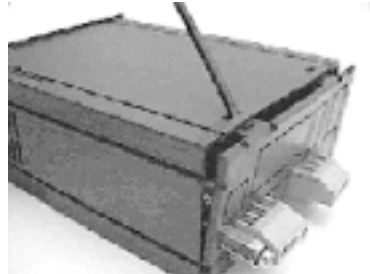

2) Remove the set composed by the base and circuits by pulling the base and carefully sliding it out.

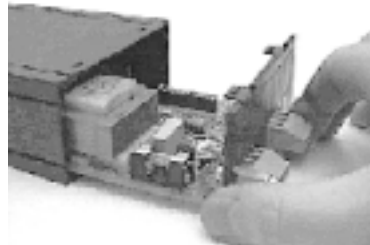

3) Insert the card into the appropriate connector . Take care that only the connector is press but not all the card.

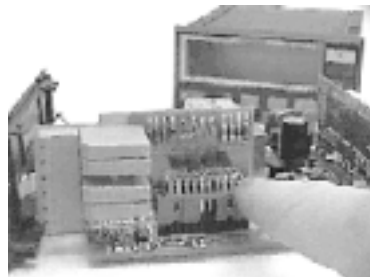

4) Put the set composed by the base and circuits in again by pushing the base and carefully sliding it into. When the set is totally inserted, press until the case holding pieces are fitted into the pertinent holes.

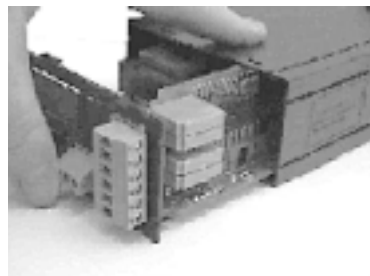

Installation and startup

## Keyboard functions

### Setup option



Pressing this key during at least 3 seconds, setup menus are accessed for user-configuration actions. Once within the setup menus, use this key to validate choices and modifications. la función de esta tecla es la de validar las selecciones.

### Peak and Valley



Pressing this key the maximum and minimum values monitored are displayed. Both values are automatically updated and stored in the instrument's E2PROM memory. To delete the peak or valley value just press this key during 3 s while the value is on screen. To exit this function press again

### Default setup values



Pressing this key during at least 5 s, default setup values replace user-configured ones. parámetros de configuración, restaurando los parámetros por defecto.

### Alarms



(Only when any alarm card is inserted)

Pressing this key during at least 3 s, alarm conditions can be visualized and modified. Pressing the button once the alarm 1 condition is shown up on screen and it could be modified if required, pressing rest of alarms will be accessed.

If any value is modified, press and to enter the new value and then press to validate this change. If the alarm is latched, the signal "Lt" is shown on display after its condition has been visualized, pressing at this moment the alarm is un-latched.

### Password



Pressing simultaneously both keys when the instrument is powered on, a 4 digit password can be set in order to control the access configuration options. To disable this password, reset the instrument and simultaneously press again both keys when powering it. Enter the set password and menus will be accessible again.

Note: The password must be always entered twice, the first one for definition and the second one for confirmation. In case that the confirmation does not match with the firstly defined password, the instrument will continue its initialization process.

## Configuration

---

The DH-96 has an easy and intuitive configuration procedure.

The instrument configuration can be carried out in a logical mode through a tree-type menu.

Steps to be followed are:

- 1) First of all, select a voltage or current input (connection mode must also be accordingly performed)
- 2) Then, define the most appropriate voltage or current measuring range among available ones. Available ranges are listed in a sticking lable placed on the instrument case.

For instance, if available ranges for the voltage are 200, 50 & 15 V, these are identified in the menu option as 200.0, 50.00 y 15.00, respectively.

- 3) Set the required position of the decimal point when the measurement is displayed on screen.

4) From this point, the instrument must be adjusted or calibrated. It is advisable before any setup action is performed to previously read the application notes according to the instrument model (alternate or direct measuring).

5) Whether the instrument is equipped with any optional card, once adjustment menu is finished, options to configure the card are enabled.

# Instruments for d.c. signal

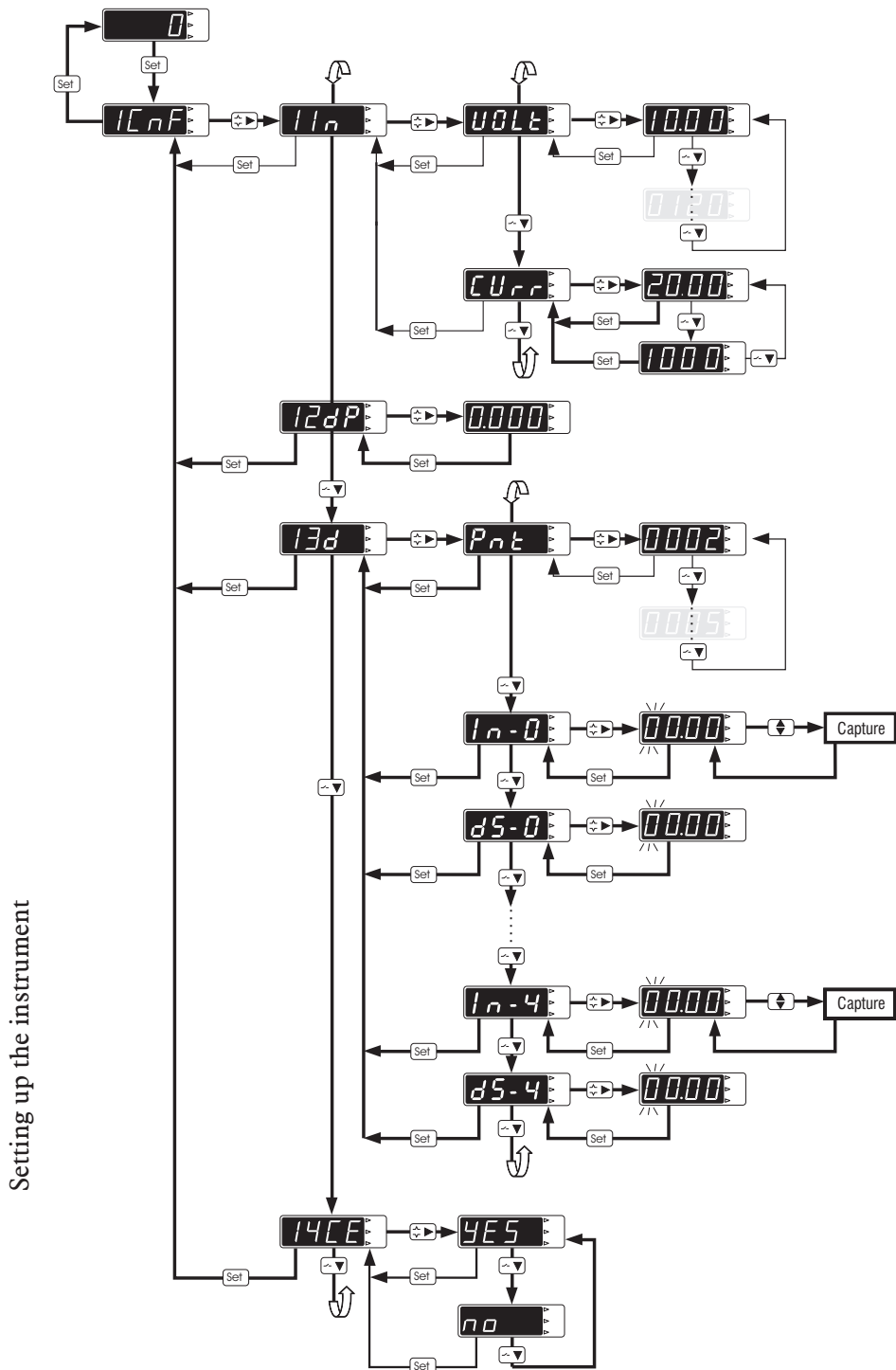

Setting up the instrument

## Instruments for d.c. signal

---



### Input

---

Set here the pertinent input type. First of all, select a voltage or current input. Then, define the voltage or current measuring range according to instrument's configurations. dentro de las configuraciones del equipo.



### Decimal point

---

Set here the required position of the decimal point when the measurement is displayed.



### Display

---

Determination of the measuring row by means of setting up to 5 point-pairs of this line. Points must be entered from lowest to highest. Define firstly the number of point-pairs to be entered. Enter then the measuring value (In - X) and following the value to be visualized on screen (ds - X). y posteriormente introducir el valor que desee visualice en el display (ds - X).



### Configuration enabled

---

Set at (No) it avoids any modification of the above parameters. Set at (Yes) it enables their modification.

### Setting a value

To cyclically move along the four digits press the key

To modify the value of the selected digit repeatedly press the key

Set the desired 4 digits value using both above keys.

### NOTES:

If no parameter is allowed to be modified, go to the last display (14CE) and check whether this is set at YES, otherwise change it.

To validate all modifications done over the instrument setup repeatedly press the key until measuring mode is again accessed.

# Instruments for a.c. signal

Setting up the instrument

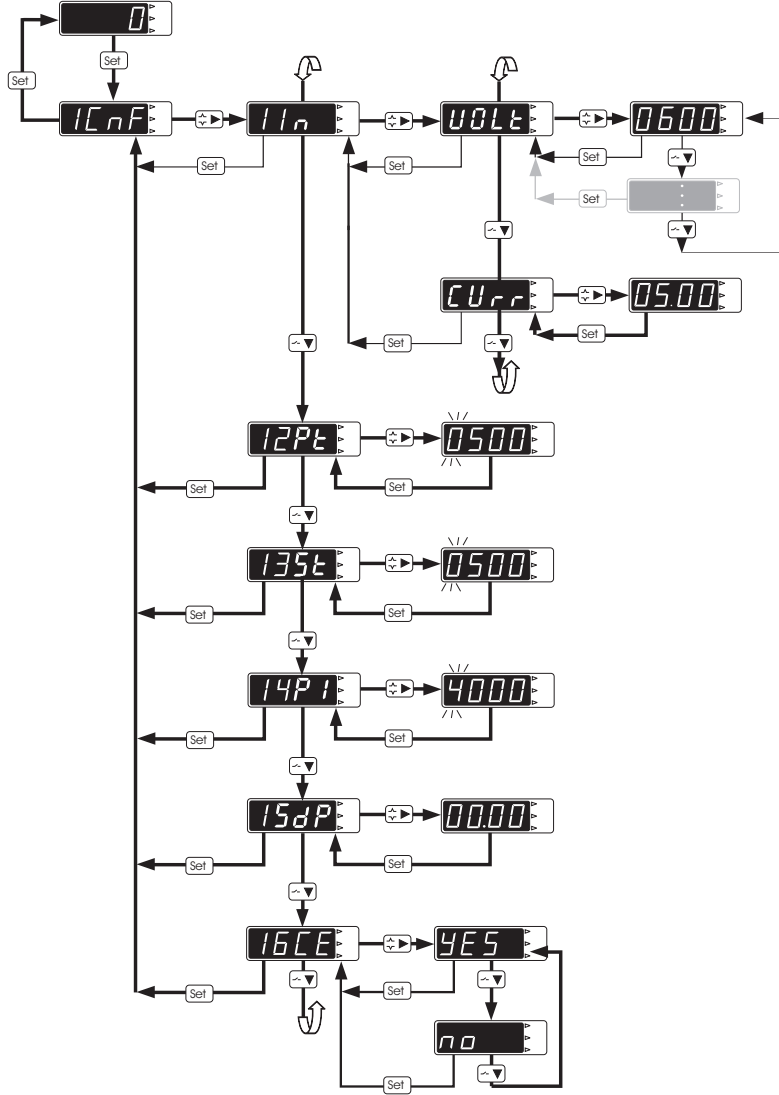



### Input

Set here the input type. First, select a voltage or current input. Then, define the voltage or current measuring range according to instrument's configurations



### Voltage primary value

Set here the primary voltage of the potential transformer (if no V.T. is used, set then this point to the same value defined at the previous point).



### Voltage secondary value

Set here the secondary voltage value of the potential transformer (if no V.T. is used, set then this point to the same value defined for the primary voltage).



### Current primary value

Set here the primary current value (provided a current input has been selected). AAAAde entrada de intensidad).



### Decimal point

Set here the required position of the decimal point when the measurement is displayed on screen..



### Configuration enabled

Set at (No) it avoids any modification of the above parameters. Set at (Yes) it enables their modification.

### Setting a value

To cyclically move along the four digits press the key

To modify the value of the selected digit repeatedly press the key

Set the desired 4 digits value using both above keys.

### NOTES:

If no parameter is allowed to be modified, go to the last display (16CE) and check whether this is set at YES, otherwise change it.

To validate all modifications done over the instrument setup repeatedly press the key until measuring mode is again accessed.

## Adjustment of instruments for d.c. measurement

The DH-96 delivers user-friendly configuration and startup procedures. First of all, we must distinguish between two types of adjustment or configuration:

### Theoretical adjustment

This adjustment procedure must be based upon some calibration theoretical data.

### Practical adjustment or adjustment in-field

This adjustment procedure must be based upon some practical measurements for calibration purposes.

Let's see a couple of examples to clarify both above concepts and its application over the DH-96.

#### Example 1:

The temperature of an oven is wanted to be measured and, for this action, we will use a temperature converter with following features:

**Measurement: 0-1500 °C, Output: 4-20 mA**

We have in this case a theoretical adjustment, since we will program the theoretical equation of our transducer into the indicator, by following these bellow listed steps:

1) Select input type (InP) as current (Curr), and set the current range at 20 mA:

Application notes

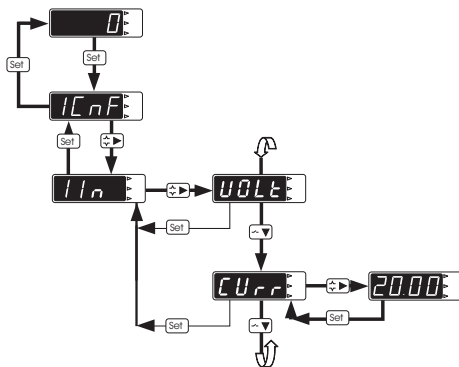

2) Set the decimal point position (dP). For this case no decimal point is required, therefore keep the default position:

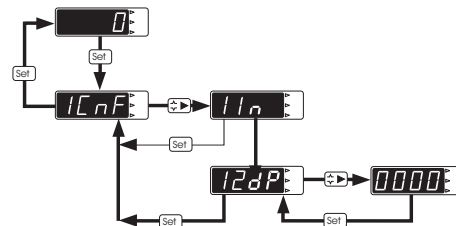

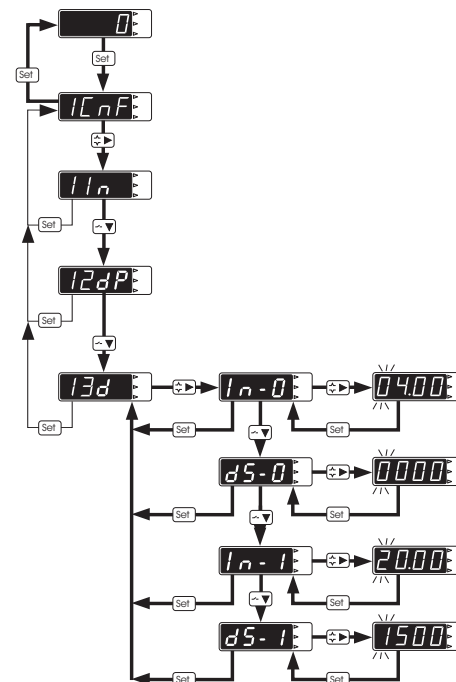

3) The instrument is now ready to be calibrated by programming the row equation:

- Set\* In-0 (Input) to the theoretical measuring value 1 (4.00)
- Set\* dS-0 (Display) to the value desired for In-0 (0000)
- Set\* In-1 to the theoretical measuring value 2 (20.00)
- Set\* dS-1 to the value desired for In-1 (1500)



## Adjustment of instruments for d.c. measurement

\* To set a value, just press  to select the digit to be modified and then use  to change its value. *s el dígito a modificar y con sasasa modificamos su valor.*

The instrument is now already calibrated and adjusted according to the required application.

4) Finally, repeatedly press  to access the measuring mode. That way, we are also validating all modifications done. Otherwise, the instrument will automatically reset to measuring mode after a lapse of two minutes (TimeOut) and no modification will be applied. .

### Example 2:

The mV given by a transducer are wanted to be monitored for the indication of kg measured by a weighting machine. The weight transducer has following features::

**Weight: 0-4000 kg, Output: 0-1 V**

The problem we meet is that the output given when the weighting machine has no load is unknown since the transducer is also measuring the weight of the own weighting machine's holder. In this case, a pattern load of 3000 kg is available. We have in this case a practical adjustment, since we will perform the instrument adjustment in field, that is, directly over the measurement. So, proceed as follows:

1) Select input type (InP) as voltage (VOLt), and set the voltage range at 1 V:

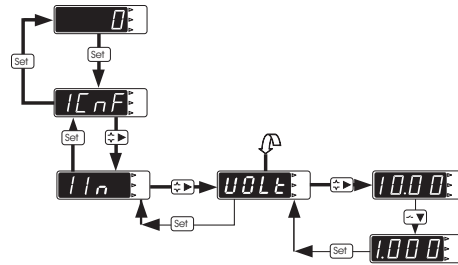

2) Set the decimal point position (dP).

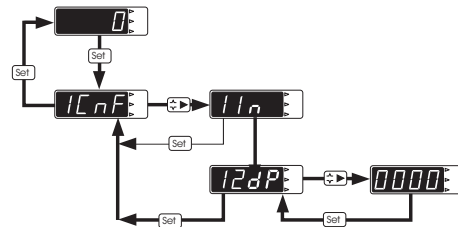

3) The instrument is now ready to be calibrated, so:

*With no load on the weighting machine)*



- At the In-0 position we will press  and the instrument will automatically capture the incoming signal, which will be shown on screen. Keep this value and pass to the next option.

- Set\* dS-0 (Display) to the value desired for In-0 (0000)

*With the 3000 kg pattern load on the weighting machine*

- At the In-1 position we will press and the instrument will automatically capture the incoming signal, which will be shown on screen. Keep this value and pass to the next option.

- Set\* dS-1 (Display) to the value desired for In-1 (3000)

\* To set a value, just press  to select the digit to be modified and then use  to change its value.

## Adjustment of instruments for d.c. measurement

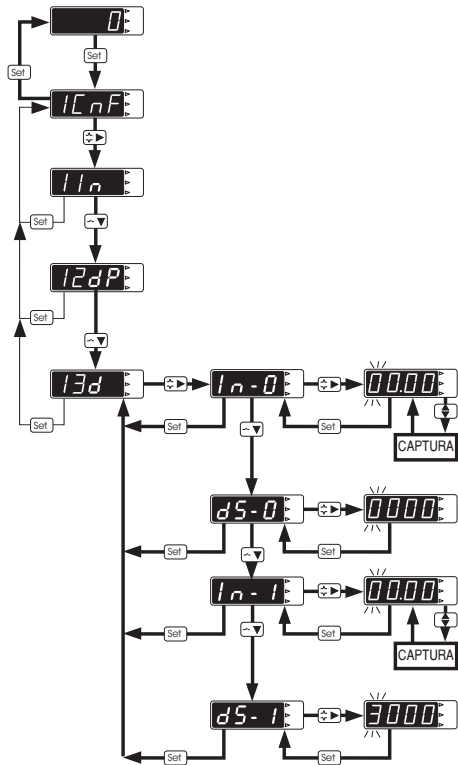

The instrument is now already calibrated and adjusted according to the required application.

4) Finally, repeatedly press **Set** to access the measuring mode. That way, we are also validating all modifications done. Otherwise, the instrument will automatically reset to measuring mode after a lapse of two minutes (TimeOut) and no modification will be applied.

Application notes

## Adjustment of non-linear equations

### Adjustment of non-linear equations:

The procedure for the instrument calibration in function of the measurement type has been explained in the previous application note. The instrument measurement is generally defined by a row equation, that is, two pair of points define the ratio between measurement and indication.

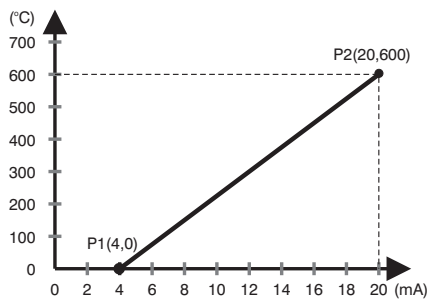

At the above graph we can see the equation of an instrument that indicates 0 for a 4 mA input signal, and 600 for a 20 mA input signal. That is, the graph is defined by two pair of points: (4,0) and (20,600) which, logically, should be as distanced as possible to attain a correct accuracy. The instrument will use this defined row when measuring to extrapolate the value that will shown on display. The DH-96 is configured by definition with two pair of points, (In-0,dS-0) and (In-1,dS-1).

However, for some cases only two pair of points might not be enough to get a correct result. Consider, for instance, a transducer for H.V. measurements with the following features:

Measurement: 0 kV, output: 4 mA,  
 measurement: 100 kV, output: 6 mA,  
 and measurement: 130 kV, output 20 mA.

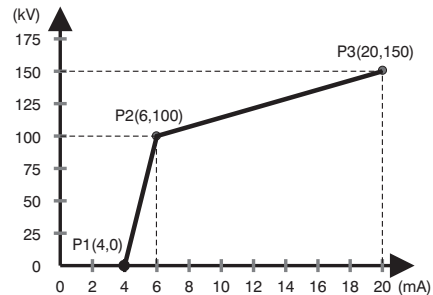

This type of output can be found at some transducers for which the measurement is only important at its rated value, and all the analog output range is used along this rated value.

For the DH-96 adjustment we need now three pair of points. To define them, once the input (voltage or current) and its range are set, the number of pair of points for the DH-96 adjustment must be modified.

The instrument is factory delivered to operate with two pair of points, in this case we must set three pair of points:

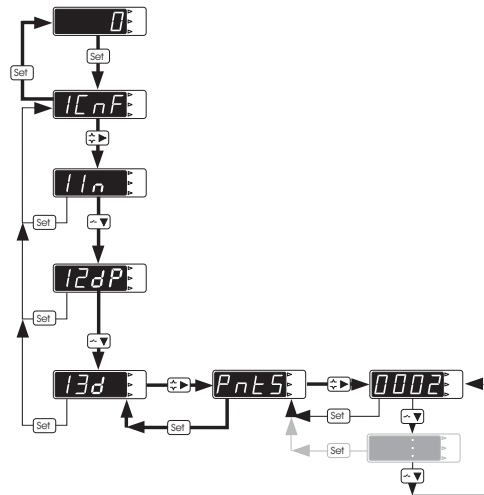

Once finished, just follow the calibration procedure (theoretical or practical) as convenient, but setting three pair of points instead of only two.

## Adjustment of instruments for a.c. measurement

The DH-96 delivers user-friendly configuration and startup procedures. First of all, we must distinguish between two types of instrument uses: as a voltmeter or as an ammeter.

### Voltmeter

Select the most appropriate measuring range and set primary and secondary voltage values.

### Ammeter

Set the primary current values.

Let's see a couple of examples to clarify both above concepts and its application over the DH-96.

#### Example 1:

The phase-to-neutral voltage of a power system is wanted to be measured. The maximum value of this voltage will be of 140 V.

Proceed as follows:

- 1) Select input type (InP) as voltage (VOLT), and set the voltage range at 150V.

Application notes

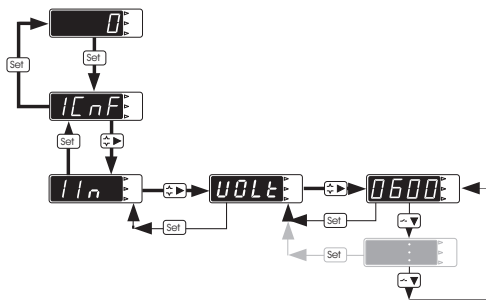

- 2) Set the primary voltage value (Pt). As for this case the voltage signal is direct and no power transformer is used just keep the default value, that is, 500.

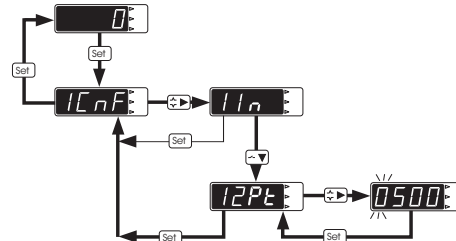

- 3) Set the secondary voltage value (St). As for this case the voltage signal is direct and no power transformer is used this value must coincide with the one set for the primary value, therefore just keep the default value, that is, 500.

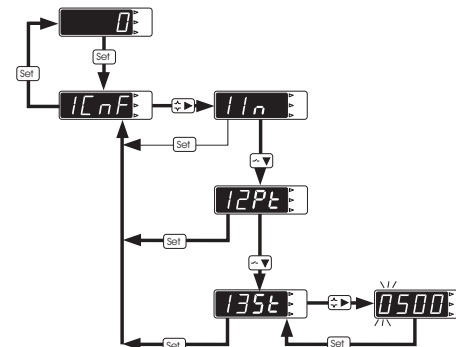

- 4) Finally, set the decimal point position (dP). For this case no decimal point is required, therefore keep the default position.

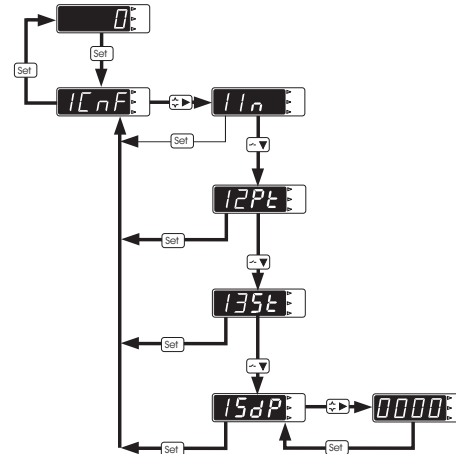

## Adjustment of instruments for a.c. measurement

The instrument is now already calibrated and adjusted according to the required application.

Finally, repeatedly press **Set** to access the measuring mode. That way, we are also validating all modifications done. Otherwise, the instrument will automatically reset to measuring mode after a lapse of two minutes (TimeOut) and no modification will be applied.

### Example 2:

The voltage of a H.V. power system is wanted to be measured through a 125000 / 110 V P.T.

Proceed as follows:

- 1) Select input type (InP) as voltage (VOLt), and set the voltage range at 150V.

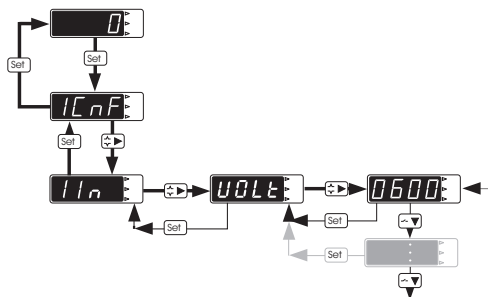

- 2) Set the primary voltage value (Pt). As 4 digits are available we will seek for a 125.0 kV indication, therefore, the value 1250 (the decimal point is not now considered) must be entered.

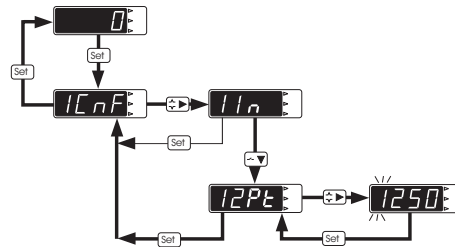

- 3) Set the secondary voltage value (St) at 110.

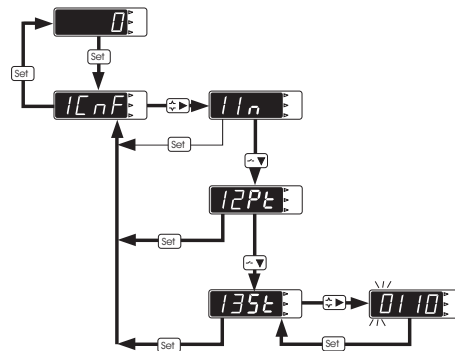

- 4) Finally, set the decimal point position (dP). For this case the decimal point must be placed between units and tens, thus obtaining a 12.5.0 indication.

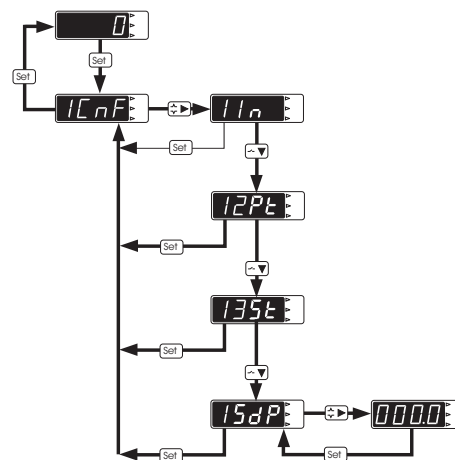

## Adjustment of instruments for a.c. measurement

The instrument is now already calibrated and adjusted according to the required application.

Finally, repeatedly press **Set** to access the measuring mode. That way, we are also validating all modifications done. Otherwise, the instrument will automatically reset to measuring mode after a lapse of two minutes (TimeOut) and no modification will be applied.

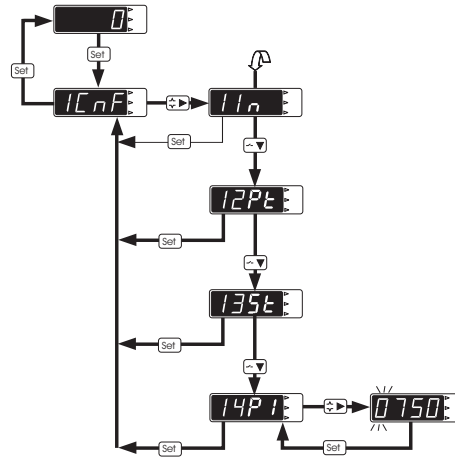

### Example 3:

The current of a circuit is wanted to be measured through a 75 / 5 A.C.T. Proceed as follows:

- 1) Select input type (InP) as current (Curr).

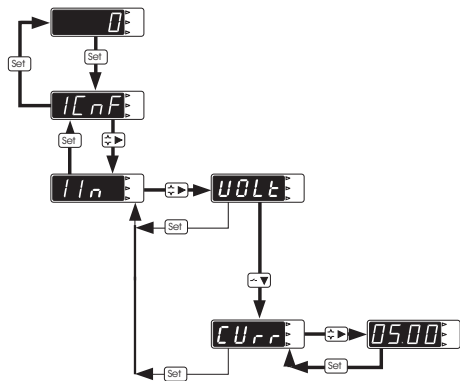

Application notes

- 2) Set the primary current value (PI). As 4 digits are available we will seek for a 75.0 A indication, therefore, the value 750 (the decimal point is not now considered) must be entered.

- 3) Finally, set the decimal point position (dP). For this case the decimal point must be placed between units and tens, thus obtaining a 75.0 indication.

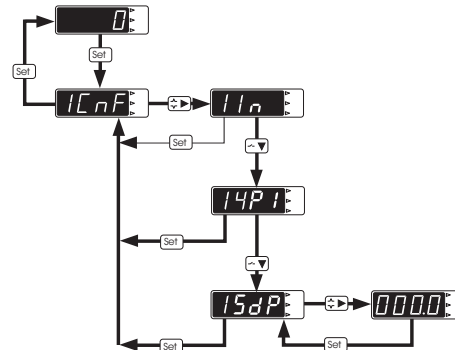

The instrument is now already calibrated and adjusted according to the required application.

Finally, repeatedly press **Set** to access the measuring mode. That way, we are also validating all modifications done.

## Modification of the auxiliary supply

---

Otherwise, the instrument will automatically reset to measuring mode after a lapse of two minutes (TimeOut) and no modification will be applied.

An instrument prepared for an auxiliary supply of 230 V can be modified for the use of an auxiliary supply of 115 V, and vice-versa.

To perform this modification, open the instrument case (see page 9, "Plugging cards"), thoughtfully following all safety warnings (see section 17.3.5 at page 6), and identify the zone referred in the figure 1.

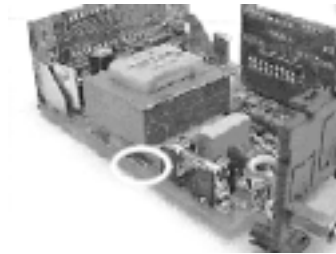

For an auxiliary supply of 230 V only the jump marked as 1 must be done (figure 2).

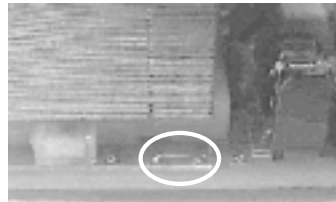

On the contrary, if an auxiliary supply of 115 V is required, only jumps marked as 2 and 3 must be done (figure 3).

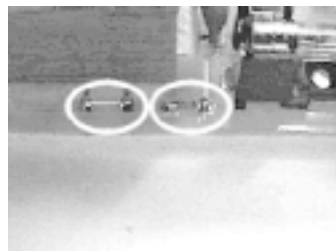

## Safety options

---

Digital indicators of the DH96 Series have several security levels for protecting configuration parameters against undesired modifications.

The last option at each menu group refers to the possibility of avoiding this parameter to be modified.

That way, if this option is set at (NO), no modification over any parameter can be performed when accessing the setup menu unless this option is reached and set at (YES).

As a stronger protection, the PASSWORD can be set to avoid accessing into the setup menu unless the password is known.

This method avoid any intentional modification to be done.

These above options deliver several security levels, such as, for instance, to avoid accessing to instrument's configuration options but allowing modifications of alarm relay conditions, ...

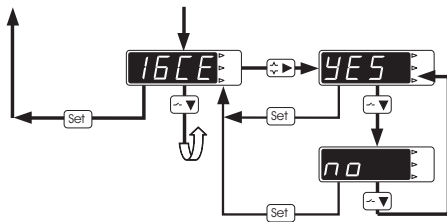

That way any accidental modification is avoided.