Chapter 1	Page
Device information	
<hr/>	
Introduction	2
Technical specifications	3
Safety warnings	4
Chapter 2	
Installation and startup	
<hr/>	
Dimensions	5
Input types	6
Wiring diagrams	8
Plug-in cards	10
Modification of the auxiliary voltage	11
Chapter 3	
Programming	
<hr/>	
Integration types	12
Demand control	13
Variables to visualize	13
Keyboard functions	14
Programming introduction	15
Device configuration	16
Relays control by level	18
Forecast control of the relays	20

In the industry, a higher power consumption than the contracted one can lead to severe penalties. Often there are power peaks produced by loads coincidence that normally do not work in a simultaneously. In order to avoid penalties, one solution would be increasing the contracted power according to the maximum registered peak, but on contrast this will force to pay a higher power than it is really needed.

Another solution will be avoiding the consumption peaks through a vigilance element that advise us of the risk situation or it can disconnect certain dispensable loads (air conditioning, compressors, lighting...)

The new **DH96-CPP** has been designed especially for the control of power demand through energy pulses. By means of this equipment, the consumed power during an integration period can be controlled, depending on the energy pulses **KYZ** that arrive to the energy meter from the utility.

To achieve this the **DH96-CPP** has up to 4 relays to connect and disconnect the required loads in the most optimum way or activating an alarm that informs us about this situation.

The equipment calculates the energy demand, peak, its medium value, and **Wh** consumed. The peak and medium demand values as well as consumed **Wh** are saved in a non-volatile **RAM**, avoiding this way its lost when the auxiliary supply drops

The instrument **DH96-CPP** has 4 digits and 8 indication red colour leds. The equipment parameters are configurable by means of 4 frontal keys.

The **DH96-CPP** has been designed to offer a wide range of features and performance qualities in a compact and at the same time robust equipment that allows to work in industrial atmospheres under all requirements of applicable standards.

Instruments of **DH96** Series have been tested in laboratories, checked in industrial environments, and have successfully passed the most rigorous tests involving ambient conditions, electrical noises, electromagnetic disturbances, mechanical vibrations, etc...

Expansion options

The instrument has an additional **RS232/485** communications card that whenever it is required can be incorporated in the device.

Through this card and by means of **MODBUS** protocol, **RTU** mode, we will be able to:

- Check the relays state, connect and disconnect them whenever is needed.
- Read all measuring parameters: demand, totalizers, peak and medium values, and reset them.
- Visualize and modify the programming parameters.

Card with RS232/485 output

- MODBUS communications protocol.
- Instrument address selection.
- Communication speed selection 1200, 4800, 9600 and 19200 bits/s.
- Parity selection: even, odd or without.
- Stop bits selection: 1 or 2.

Technical specifications

Auxiliary supply:

Rated value:	115V or 230 V a.c. / 24 or 48 V a.c. (-15 %, +20 %)
Frequency range:	45 to 65 Hz
Burden:	4 VA (without optional card) 7 VA (maximum burden)

Display :

7 segments
14 mm high 4 digits
Hi-efficacy red colour
Overrange indication "----"
8 indication LED
Programmable decimal point

Input circuit:

Free contact:	Vc	5 V
	Rc	3,9 k
TTL / 24V:	Rc	47 k
	Logic Level 0	< 2 V
	Logic Level 1	> 3 V
NPN or PNP sensor:	Rc	≈ 2 k
	Logic Level 0	< 2 V
	Logic Level 1	> 3 V

Isolation:

Between the input circuit, the measuring circuit and the output measure-relay, RS 485 /232

Test voltage:	3 kV RMS 50 Hz during 1 min
Pulses test:	4 kV (1.2/50 μs)

Environmental conditions:

Storage temperature:	-40 °C to +70 °C
Operation temperature:	-10 °C to +65 °C

General characteristics:

Dimensions:	96 x 48 x 138 mm
Weight:	550 g
Case material:	ABS V0, anthracite grey
Protection degree:	Frontal: IP 54 IP 65 with frontal protect
	Case: IP 20
	Terminal: IP20

Relays features:

1 single contact

Rated A.C. current :	5 A
Maximum A.C. current:	250 V a.c. 50 Hz
Maximum resistance load:	750 VA
Isolation resistance 500 V:	> 1000 M
Contact-coil isolation:	2000 V c.a.
Contact-contact isolation:	750 V c.a.
Mechanical endurance:	> 20.000.000 operations.
Electrical endurance:	> 30.000 operations at 5 A. and 250 V

Design standards:

IEC 1010 / IEC 348 / IEC 664 / EN50081-2 / EN50082-2 / ANSI C12.5-1978/ UL508/
C22.2 No 14 / VDE0435

Information and warning texts

The DH96 meets protection class I:

- It is provided with earth terminal.
- The case is not dangerous to tactile touching (isolation material)
- Screws of terminals are not accessible for human appendix.

This instrument has been designed and tested to meet IEC348 standard and is supplied in proper conditions. This manual contains information and warnings that the user should respect in order to guarantee a proper operation of all instrument's functions and keep its safety conditions.

Installation

The instrument is for indoor use. It could be occasionally subjected to temperatures between -10 °C and +75 °C keeping its safety conditions.

The instrument must not be powered and used until being correctly assembled on the board.

Before powering the instrument, its earth terminal must be connected to a suitable protection cable.

⚠Warning!

Any interruption of the protection conductor, either inside or outside the instrument, or the disconnection of the protection earth terminal might imply a dangerous situation; therefore, any intentional interruption is wholly forbidden.

Adjustment, spare parts and repairing actions.

With the instrument powered on, the terminals could be dangerous to touch and cover opening actions, may allow accessing dangerous parts. Therefore, before any adjustment, replacement, maintenance or repairing operation is carried out, the instrument must be switched off from any power supply source

No adjustment, maintenance or repairing operation should be done over the instrument opened and powered, and if they are essential, high-qualified operators must perform them.

Check that fuses used for replacing damaged ones match required types and rated currents. Unsuitable fuses or short-circuit fuse bases must be completely forbidden.

Defects and malfunction

When any protection failure is supposed to exist, the instrument must be put out of service. The protection can be damage whether:

- You can see visible damages.
- It cannot perform proper measurements.
- Storage conditions were not the suitable ones.
- Any damage in transport happened.

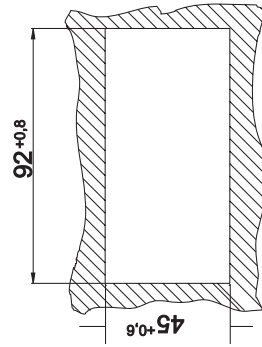
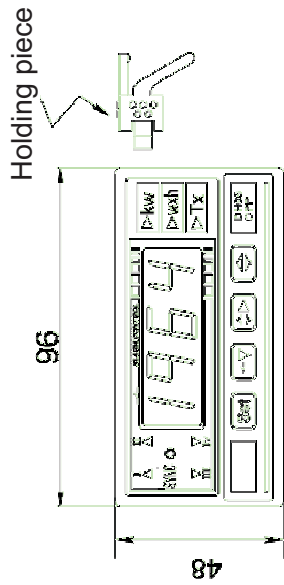
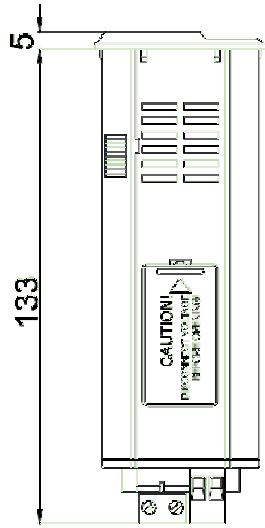
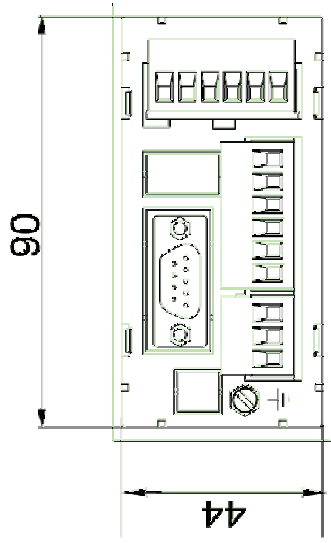

Panel cut-out

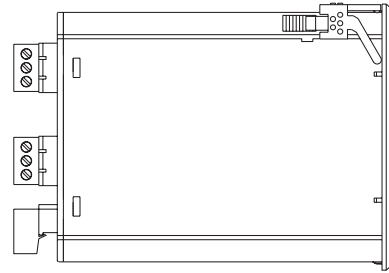

Input types

Utility meters generate output pulses with type C contact, known as **KYZ** pulses, where each contact is a pulse.

The **DH96-CPP** uses type two wires **A** contact, this can be obtained from type **C** using either **KY** or **KZ** only.

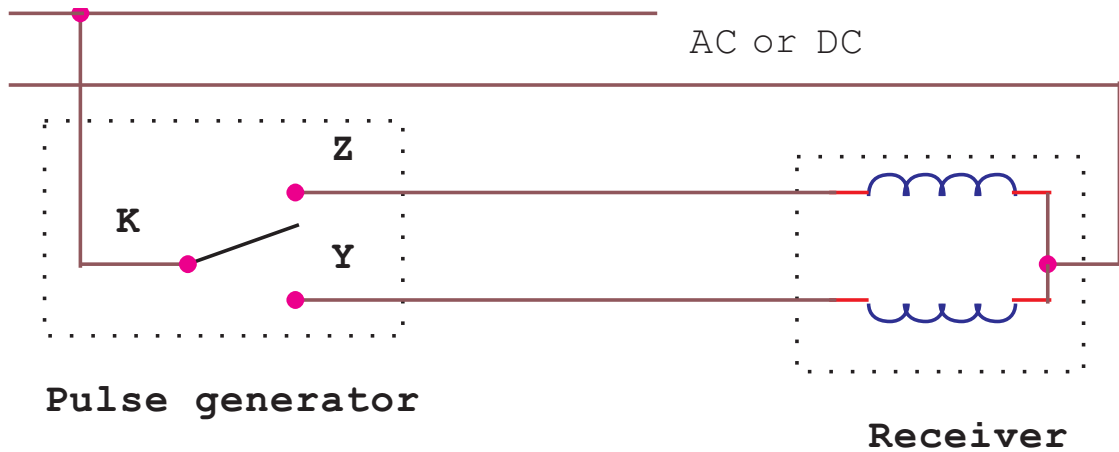

Pulse KYZ form C

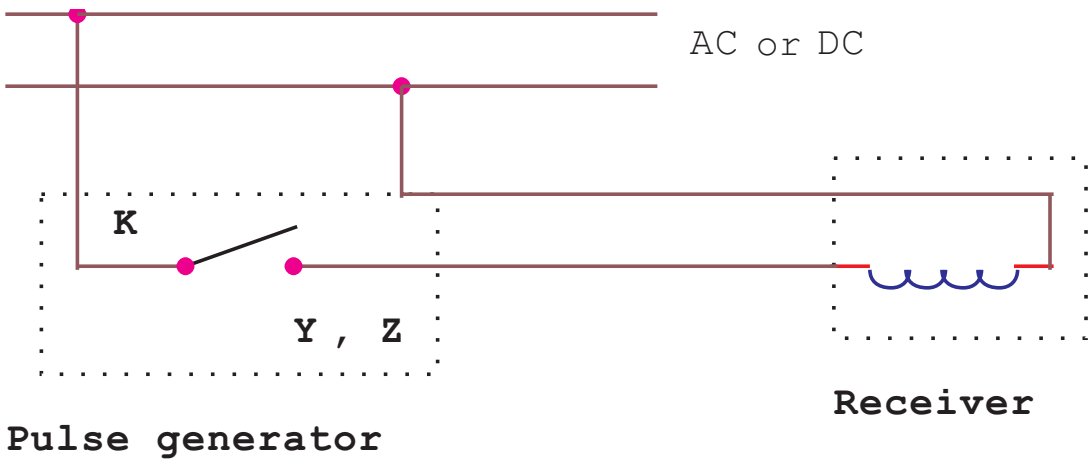

Pulse KYZ form A

For it, the **DH96-CPP** will count a pulse whenever the position of the contact should be modified, it's means, in every change of level.

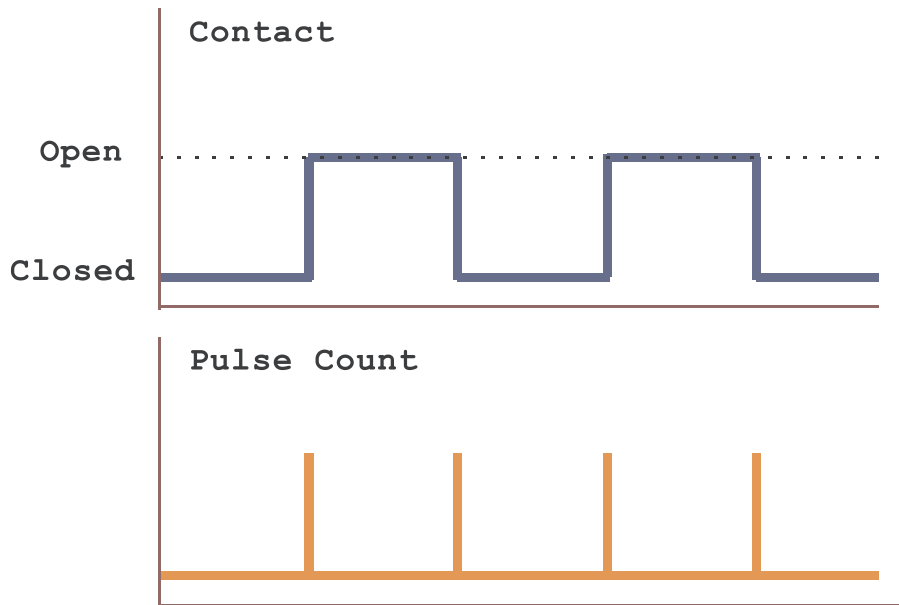

The **DH96-CPP** admits, for each of his two inputs **-KYZ** and **synchronism input pulses**- the connection through:

- Free potencial pulses,
- Pulses by level of voltage (TTL/24V),
- NPN or PNP sensors.

The connexion type will be selected by means of the on-board microswitches, SW. For accessing these microswitches the box must be opened according to indications in the page 10 (**Plug-in cards**).

Once these microswitches have been located, select the transducer to be used just following indications attached in the table.

Note: The instrument is factory shipped for the use a free potencial pulses.

SW1	KYZ pulses					synchronism pulses				
	1	2	3	4	5	6	7	8	9	10
Free potencial pulses	on	off	on	on	off	on	off	on	on	off
TTL/24V	on	off	off	off	on	on	off	off	off	on
NPN sensor	on	on	off	off	off	on	on	off	off	off
PNP sensor	on	off	off	on	off	on	off	off	on	off

Wiring diagrams

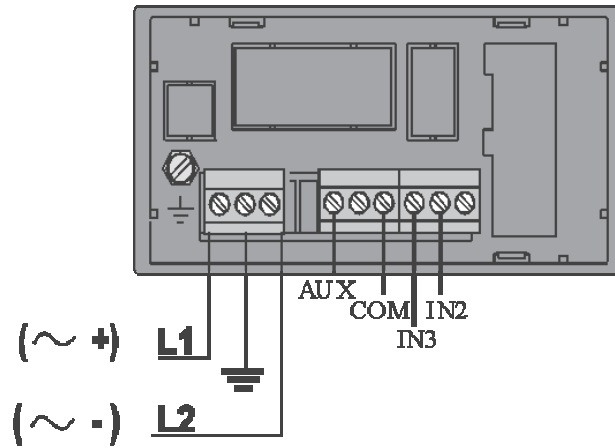

1.- Connection for free potential pulses,

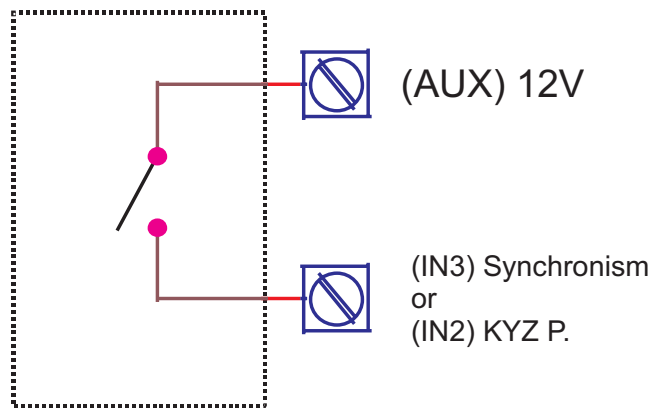

2.- Connection for pulses by level of voltage (TTL/24V),

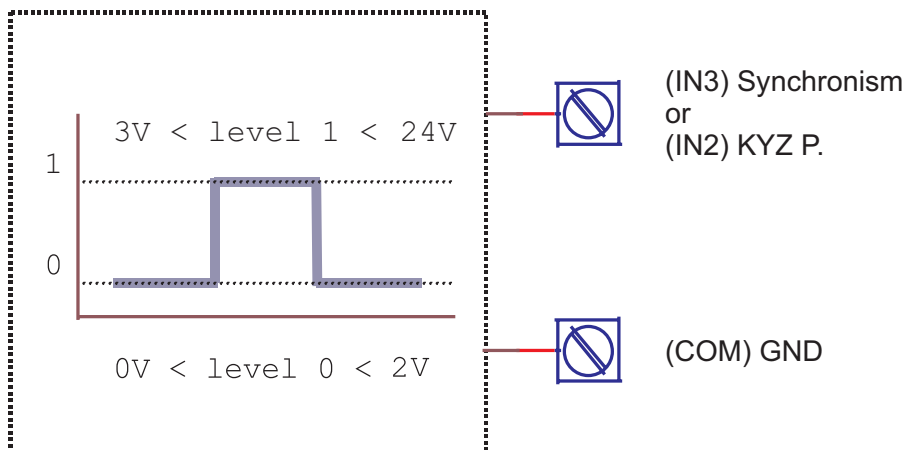

3.- Connection for NPN sensor

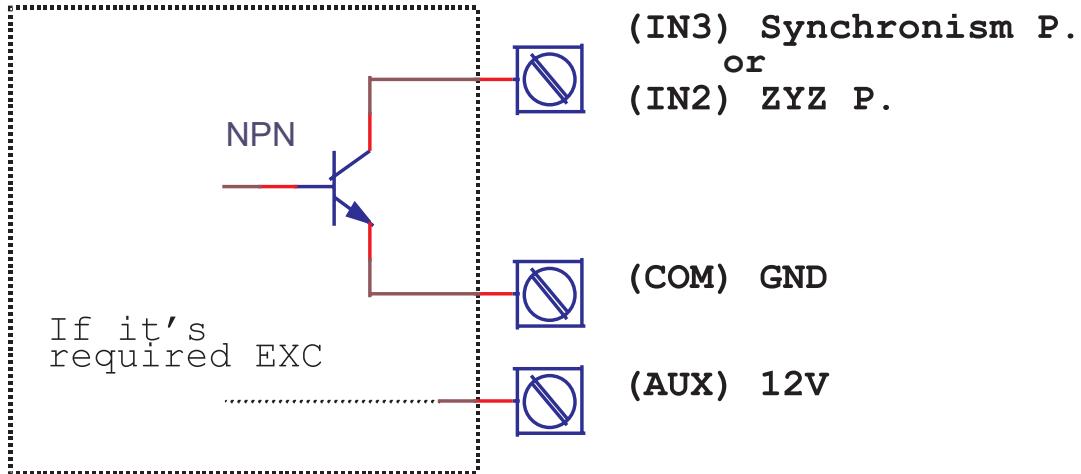

4.- Connection for PNP sensor,

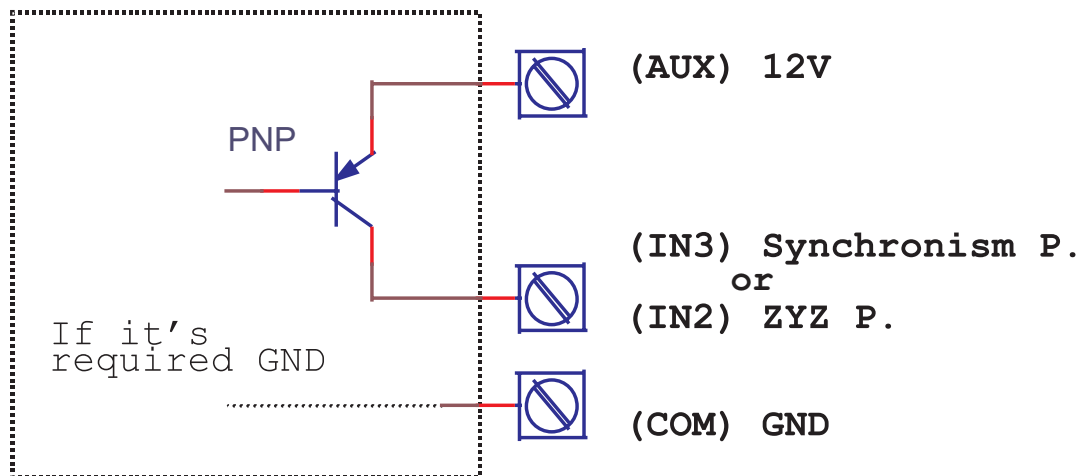

Cards: Connection of relays

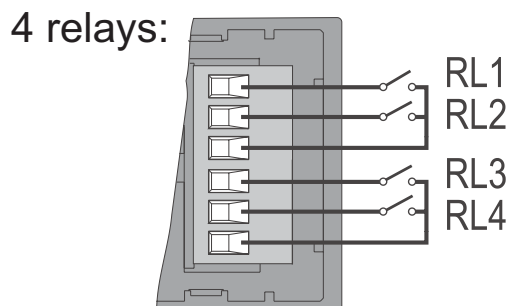

Plug-in cards

WARNING: Insure that no incoming wire is connected to the equipment before doing any manipulation work on the equipment, since observed failure in the equipment can provoke equipment damages and even serious injury.

Proceed as pictures show below:

1) Press the case holding piece with a screwdriver or a similar tool in order to release the base from the rest of the case.

2) Remove the set composed by the base and circuits by pulling the base and carefully sliding it out.

3) Insert the card into the suitable connector. Take care that only the connector is pressed but not all the card.

4) Put the set composed by the base and circuits in, again, by pushing the base and carefully sliding it inside. When the set is totally inserted, press until the case holding pieces are fitted into the pertinent holes.

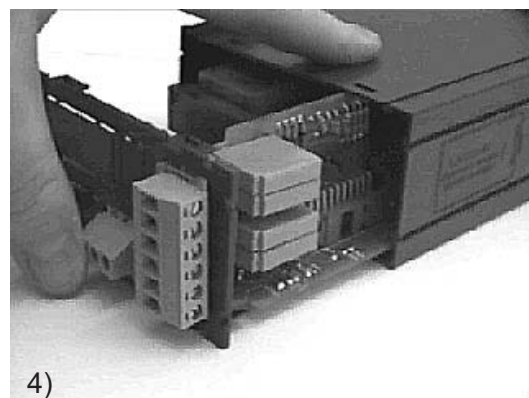
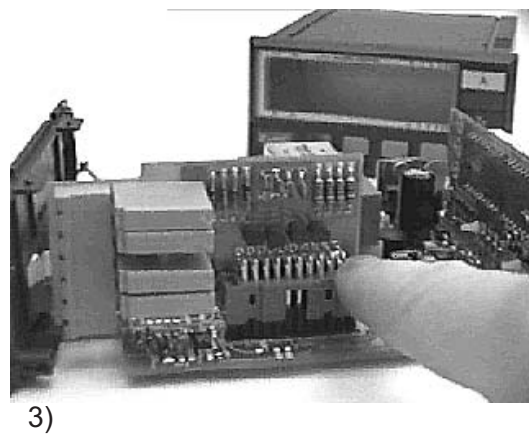
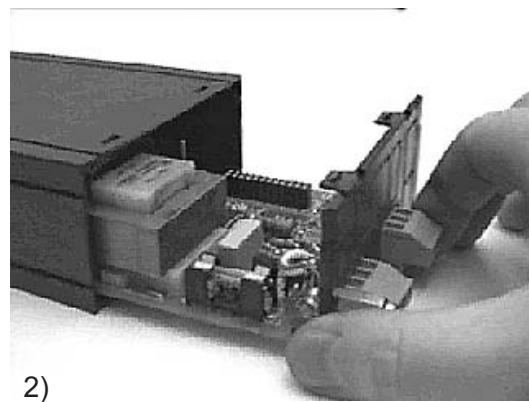
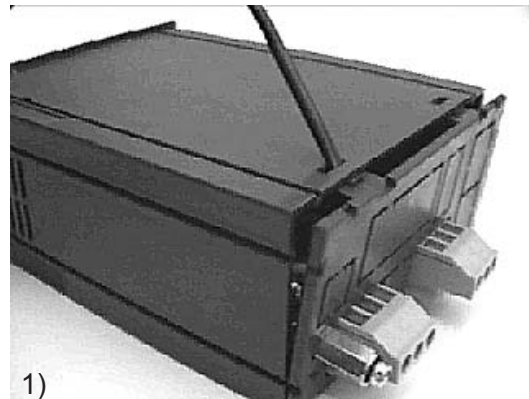

Modification of auxiliary voltage

The instrument is manufactured to be supplied with 230 V a.c. But it is possible to change to 115 V a.c. Following the instructions below mentioned:

To perform this modification, open the instrument case (see page 10 "**plug-in cards**") thoughtfully following all **safety warnings** (see page 4), and identify the zone referred to picture 1.

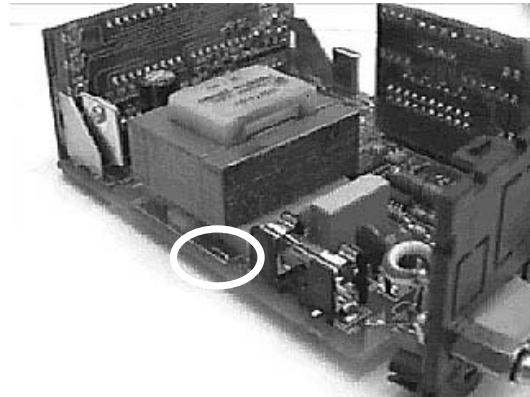

fig. 1

For an auxiliary supply of 230 V only the jump labelled as 1 must be done (fig. 2)

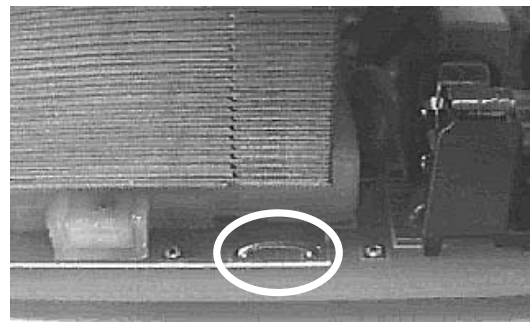

fig.2

On the contrary, if an auxiliary supply of 115 V is required, only jumps labelled as 2 and 3 must be done (fig. 3).

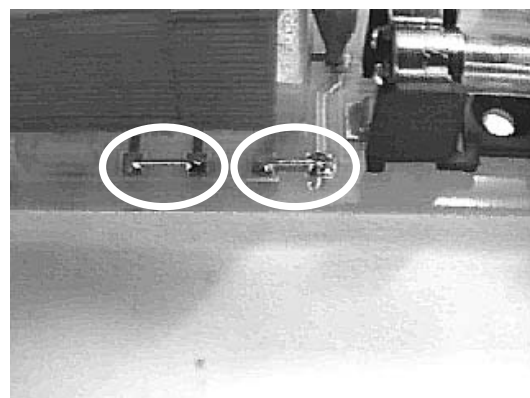

fig. 3

Integration types

The **DH96-CPP** can be programmed in order to operate in 4 different integration modes:

1 - Synchronised with the utility maximeter, through synchronism pulses that are given in each period initiation (**Block demand Pulse**).

2 - Synchronised with the utility maximeter, by means of synchronism pulse. (**Block demand Time**). From this pulse, the equipment calculates the starts and ends of each period based in an internal clock. When a new pulse is received, it will be re-adjusted and it will be synchronised again. (It is recommended to receive one synchronism pulse each 24 hours.)

3 - Without synchronism with the utility maximeter, using a sliding window (**Rolling demand**).

4 - Without synchronism with the maximeter, using a sliding window and simulating the response of the thermal exponential function of the mechanical meters (**Thermal demand**).

Example:

Following the graph you can observe the behaviour of the device in the 4 operation modes, for an integration period of 5 minutes.

For synchronised operation mode (block demand pulse and block demand time) and Rolling (sliding window) the device will reach up to the maximum value of the demand, in this case 36 kW, at the end of the integration period (5 minutes).

For **Thermal** operation mode, the **DH96-CPP** will get up to 90% of the maximum demand value at the 5 minutes, and up to 99,9 % at 10 minutes.

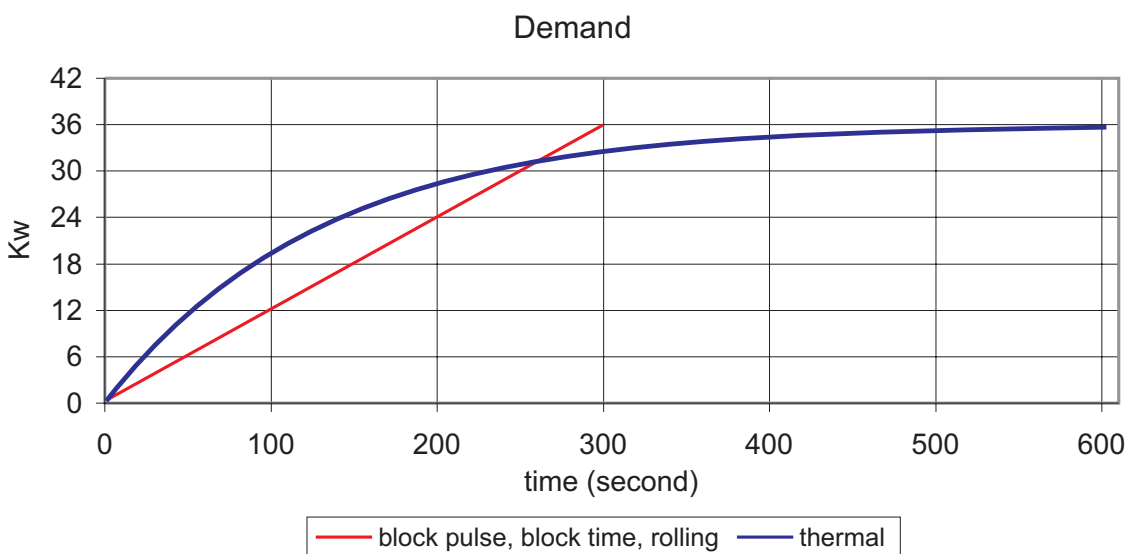

Demand Control

This device has two operation modes in order to getting the relays control:

-Control by level, for Rolling, Thermal, Block demand pulse and Block demand Time operation modes.

-Predictive control, for Block demand pulse and Block demand Time operation modes.

If the option of **control by level** has been chosen, we will program the value for each one of the relays that we want to disconnect its load when the demand value exceeds it. In this option, we will be able to introduce delays in the relay's disconnection, in the connection, hysteresis, latch option, failure security... for each of the programmed loads.

In the **predictive control**, connection and disconnection of the loads will be made by means of one algorithm that optimises the number of manoeuvres and guarantees the contracted power cannot be exceeded, provided that the programmed values are the ones that really are in the installation. In order to achieve this, we must program the contracted power from the utility and the individual power of each load that we will link to the **DH96-CPP**.

If the 4 existing relays are not used, the 4th relay acts like an alarm, it activates itself when all the loads have been disconnected.

Variables to visualize

The DH96-CPP is based on a microprocessor, that calculates from KYZ pulses the following parameters:

-Energy demand (kW), in any of the 4 calculation programmable modes

-Peak value of the demand, it is the maximum value of the demand it has been reached.

-Medium value of the demand, it is the average of demands reached in the last 32 integration periods.

This value is visualized for the synchronised operation modes only. For a 15 minutes of integration period it will be the average of the last 8 hours.

-Consumed Wh. It exists three totalizers than can count up to 999,999,999 Wh.

Peak and medium demand values as well as the **Wh** totalizers are saved in a non-volatile **RAM** memory, that can be displayed whenever it is required, avoiding the lost of the same if the auxiliary supply drops. This system does not require any maintenance.

Wh totalizers, medium and peak values, can be reseted whenever it is needed.

Keyboard functions

Programming



By pressing this key, we will accede to program menus of the several parameters that can be defined. Once inside this menu, its function will be validating selections.

Visualization



This key allows to display and change from demand to totalizers visualization.

Totalizers visualization / peak and medium values



If we are visualising the demand, we will be able to see the peak and the medium value by pressing this key.

If we visualize totalizers, we will be able to display cyclically the three totalizers: A totalizer (from 0 up to 999 MW), B totalizer (from 0 to 999 kW) and C totalizer (from 0 up to 999 W).

For instance: If the totalizer's values are: A:357, B:027, C:146 the total consumed Wh is: 375,027,146 Wh.

Totalizer's / peak and medium values reset



If we are visualising the demand, we will be able to reset the peak and medium value, by pressing this key during more than 5 seconds. If we are visualising totalizers, we reset their values.

Default values



Pressing both keys at the same time, during more than 5 seconds, the equipment deletes all configuration parameters, restoring the default parameters.

Password



Pressing both keys at the same time, when we switch on the instrument, we will be able to introduce a 4 digits password. The function of this password is to forbid the access to the configuration menus of this device. For deleting this effect, you must re-start the equipment, and you must press both keys at the same time. After introducing the previous password, you will have access to the menus again.

Remark: The introduction of the password, either for protection the access to the menus or deleting its protection must be done twice, the first time for its definition, and the second one for confirm it. If the second time does not coincides with the first, the devices considers it is a mistake, and it goes on with its starting routine.

Besides, in the **DH96 CPP** we have another security level against parameters' modification. At the end of each menu group appears the **CE** feature, with **YES** and **NO** options.

For instance, if we have programmed the equipment configuration and we choose **NO**, when we accede into this menu again, we will not be allowed to modify any parameter, and it will be required to enter into this option again and activating it with **YES**.

DH96 CPP configuration is easy, intuitive and makes the user familiar with it , allowing whenever he requires, without using the manual, the modification of the different programming instrument's features.

By means of a program menu, disposed in a tree mode, he can program all the equipment's operation in a logical way.

The steps to follow are:

1) Firstly the user will program the device's configuration, where he will be able to settle: the energy that belongs to each pulse, operation type, integration period, decimal point position, and operation mode.

2) Following on, if there is a relays cards and we have programmed the device in **Block** operation mode, we will choose the control type of the relays: relays control by level or predictive control.

3) Finally, we will program the relays' configuration Menu that appears depends on previous selection.

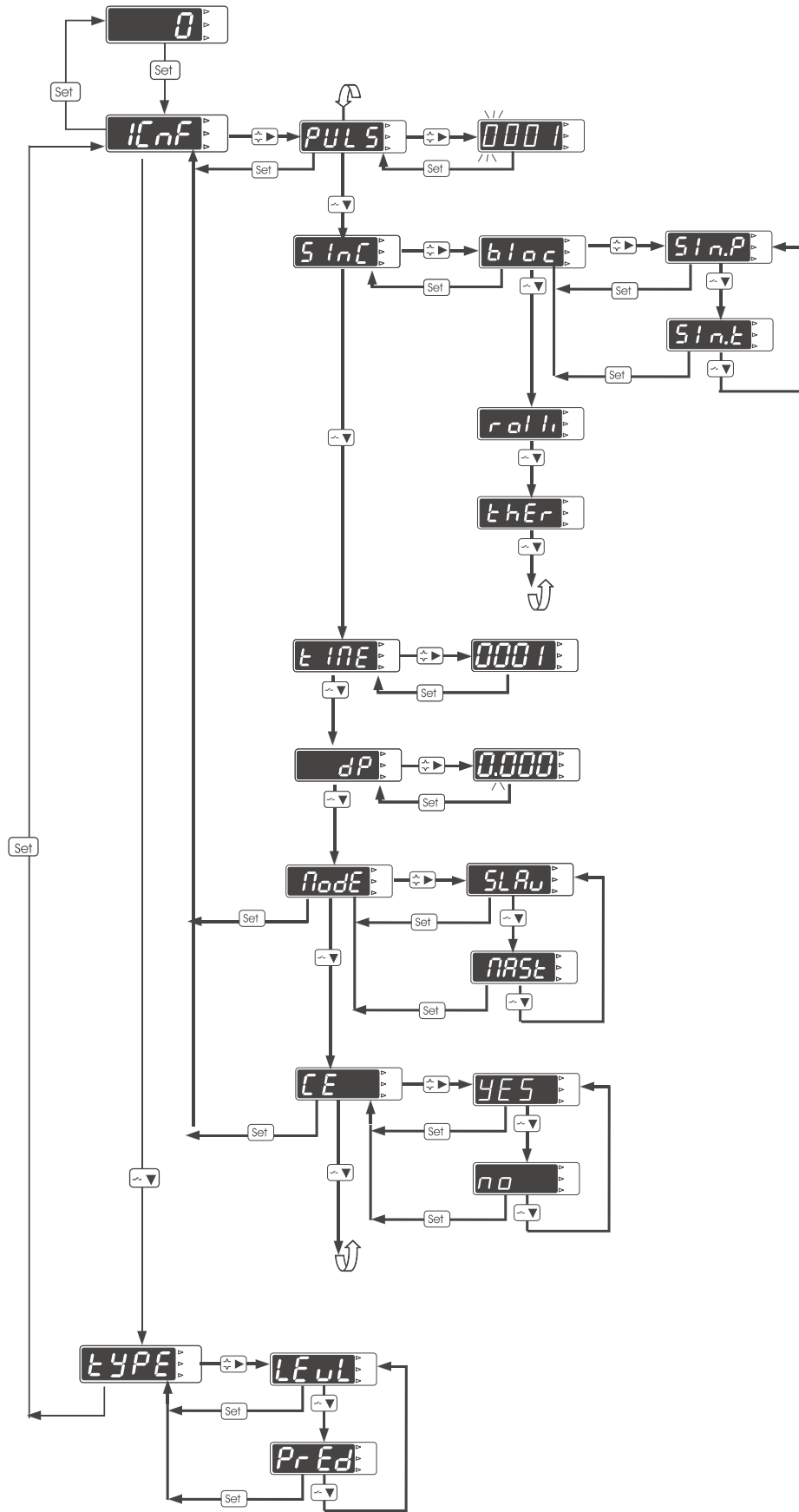

PULS

Energy pulses

The energy value in Wh belonging to each KYZ pulse is introduced.

SInC

Integration type

The integration type of the device is determined in this section :

blac

Synchronised with the utility's maximeter,

SInP

-through synchronism pulses that are given in each period start.(Block demand pulse)

SInE

-by means of a synchronism pulse.(Block demand time)

rali

Without synchronism, using a sliding window.

thEr

Without synchronization, using a sliding window and simulating the response of the thermal demand (exponential).

tIME

Integration period

Here you are introducing the integration period in minutes (from 1 to 60). In the thermal mode, it is the period in which we want to have the 90% of the final value.

dP

Decimal point

We select the position of the decimal point to display the instantaneous demand.. Pressing the  key we are varying the position of the decimal point.

Mode

Working mode

We select the working mode of the DH96, in **master** mode the unit is controlling the relays, in **slave** mode the user controls the relays by modbus.

CE

Configuration enabled

If the user programs the device as (No) it disables the modification of the previous parameters and as (Yes) it enables the modification.

TYPE

Relay control

This option appears only if we have programmed the synchronization mode (**block demand pulse** or **block demand time**).

The device has two working modes to control the relays:

LEvL

control by level,

PrEd

control by forecast.

The menu to configure the relays depends on this selection.

Programming of one value:

To step from one digit (4 digits) to another, press the following key 

To modify the value of the selected digit press repeatedly the key 

By means of the two keys we will define completely the 4 digits of the value.

NOTE:

If you see that it is impossible to change these values, go to the **CE** option and check that it is programmed with (**YES**).

To validate the values, remember that the key  should be pressed repeatedly, until you arrive to the measured value.

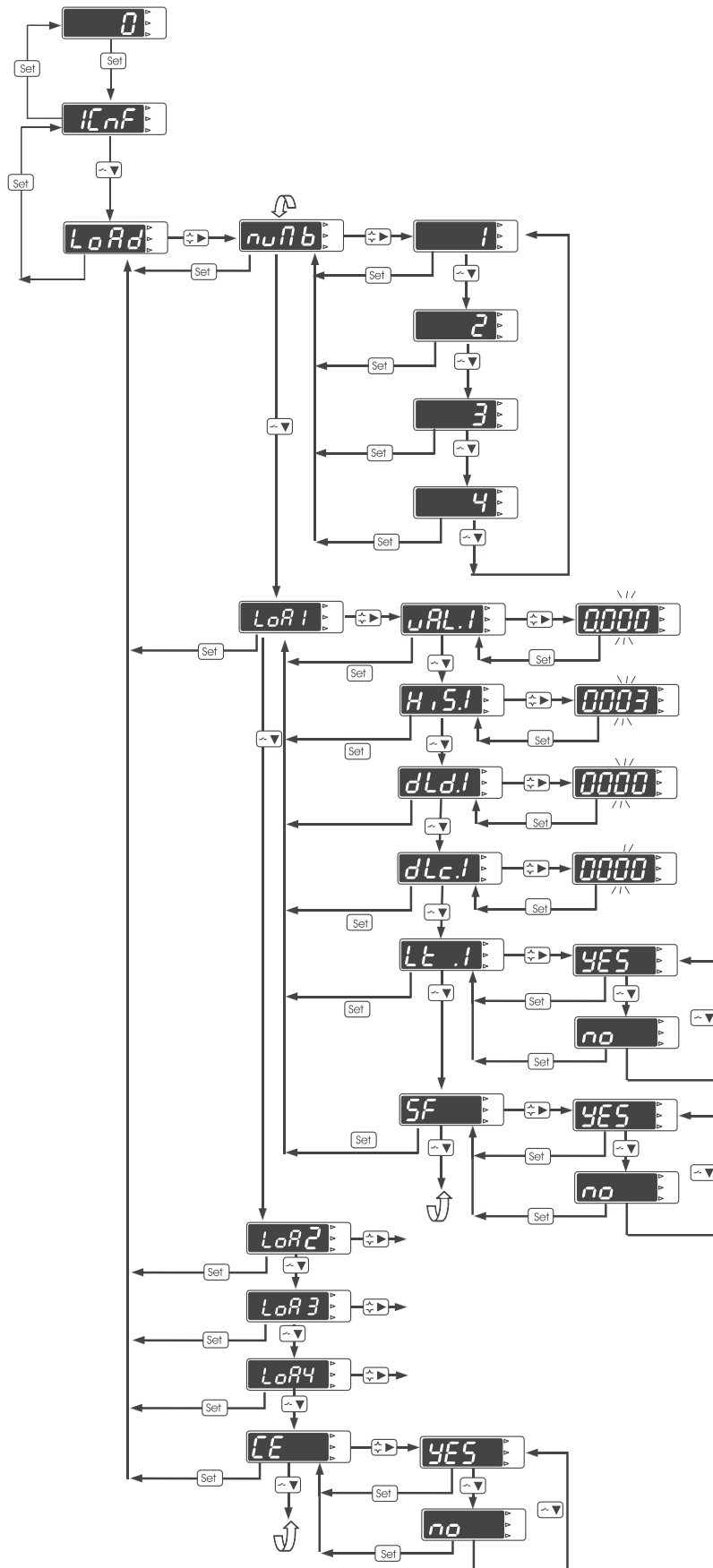

nu7**b**

Number of relays

We select the number of relays that we will use.

For each of the relays, we will program the following parameters:

wAL.1

Value of the alarm

We introduce the value of the instantaneous demand which will trip the corresponding alarm.

The value of the alarm 1 should be the smallest one, and therefore:
alarm1 < alarm2 < alarm3 < alarm4.

H.5.1

Hysteresis

Introduce the desired difference between the connection point and the disconnection point of the load in % (minimum 4%, maximum 50%)

dLd.1

Delay on the disconnection

Introduce the delay that there will be between the time in which the alarm level has been reached and the time the relay is disconnected. (in seconds).

dLc.1

Delay on the connection

Specify the delay that there will be between the time in which the alarm disappears and the time in which the relay is connected again (in seconds).

Lt.1

Latch

We are specifying in this option if we wish to latch the relay once the relay has tripped even though the alarm condition might disappear.

SF

Security failure

We can choose over here between a normally close relay (**Yes**) or normally open (**No**).

CE

Configuration enabled

Programmed in (**No**) it disables the modification of the previous parameters, and in (**Yes**) it enables the modification of them.

Forecast control of the relays

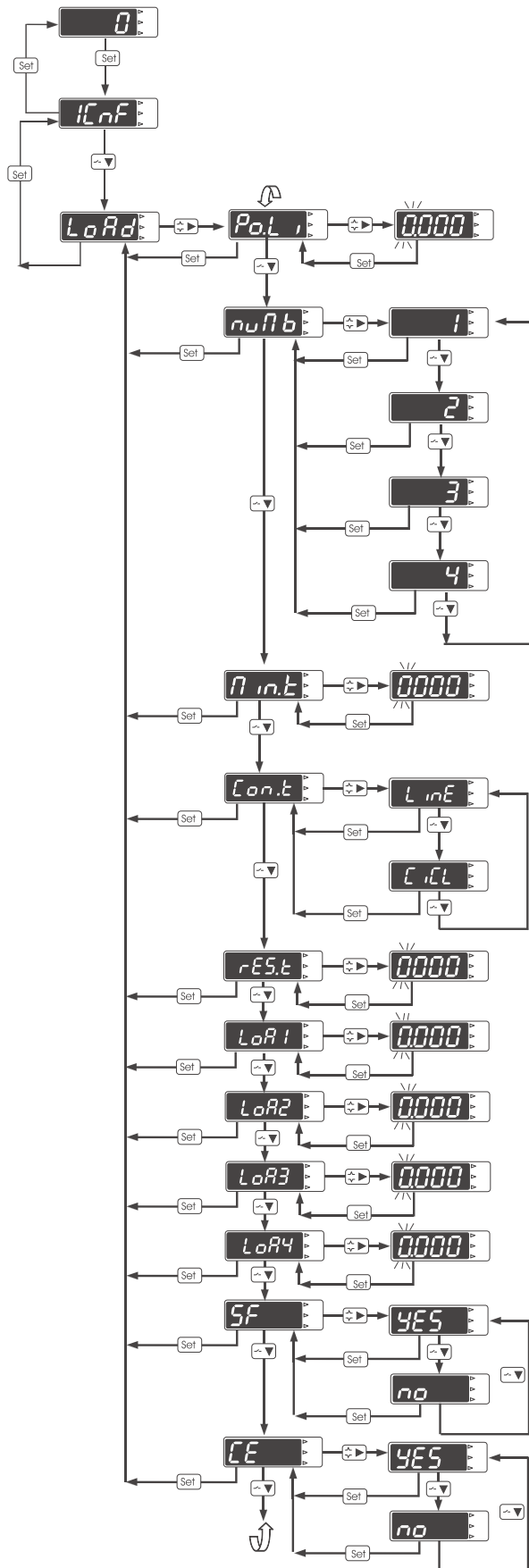

Pol

Contracted power

We introduce the value of the contracted maximum demand with the utility (in kW)

numb

Number of relays

We select the number of relays that we will use.

int

The delay in the connection

Specify the delay that there will be between the time in which the alarm disappears and the time in which the relay is connected again (in seconds).

Cont

Type of connection / disconnection of the relays)

We can select among the two different types of connection / disconnection.

CEL

- **cyclical**, where we disconnect first the relays that have been connected for a longer time

LINE

- **linear**, where the connection and disconnection is made by priorities. (the relay 1 is the first one to be disconnected).

rest

Transient time

Depending on the load on the installation, we can have transient quick variations on the power (for example installations with a lot of inductive load) but which should not cause an immediate action by the controller. By means of the transient time, we can adjust the response time of the controller to the characteristics of the installation.(in seconds).

LoRI

Power

For each of the relays, we introduce the power that each of the relays controls (in kW).

SF

Security failure

We can choose over here between a normally close relay (**Yes**) or normally open (**No**).

CE

Configuration enables

Programmed in (**No**) it disables the modification of the previous parameters, and in (**Yes**) it enables the modification of them.

