

CMM 96

Digital three-phase measurement station for panel mounting



Description

- Measures V, A, Hz and unbalances per phase
- Measurement in true root mean square (TRMS)
- Optional expansion of its functions with expansion modules:
 - 4 fully programmable relays

Application

- Ideal for unbalanced 3 or 4 wire three-phase networks for the analysis of electrical parameters.
- Time control with the timer function, (type **CH**)
- Control of the maximum demand, thanks to the maximeters available per phase (type **MD**)

Features

Power supply circuit	
Power supply	230 Vac (-10 ... +15 %)
Frequency	35 ... 450 Hz
Consumption	5 V·A
Measurement circuit	
Scope	400 V F-N, 565 V P-P ... / 5 A
Accuracy	0.5 % (± 2 dig)
Overload (permanent)	1.2 I_n
Consumption	0.6 V·A
Frequency	35 ... 450 Hz
Display	
Display	Three 4-digit lines
Colour	Red, high efficiency
Display refresh rate	1 s
Ambient conditions	
Storage temperature	- 40 ... +70 °C
Operating temperature	- 10 ... +65 °C
Build features	
Box material	Self-extinguishing ABS
Degree of protection	IP 54 front panel
Size	96 x 96 x 87 mm
Weight	350 g
Standards	
IEC 1010, IEC 348, IEC 664, EN 50081-1, EN 50082-1	

CMM 96

Digital three-phase measurement station for panel mounting



References

Measurement	Parameters	Input	Type	Code
AC	V, A, Hz and MD per phase	400 V _{p-n} / 565 V _{p-p}	CMM96-MD	M20511
AC	V, A, Hz per phase and timer	400 V _{p-n} / 565 V _{p-p}	CMM96-CH	M20512

Expandable modules

Inputs	Outputs	Type	Code
-	4 relays	Module with 4 relays CMM 96 -MD	M20522
1 CH input	4 relays	Module with 4 relays CMM 96-CH	M20524

Coding table

Code		Internal Code	
M	2	X	X
X	X	X	0
X	0	0	X
X	X	X	X
Auxiliary power supply		Standard (230 V)	0
		400 V ac	3
		18 ... 36 V dc	7
Insulated inputs		Standard (not insulated)	0
		Insulated - ITF	1

Dimensions

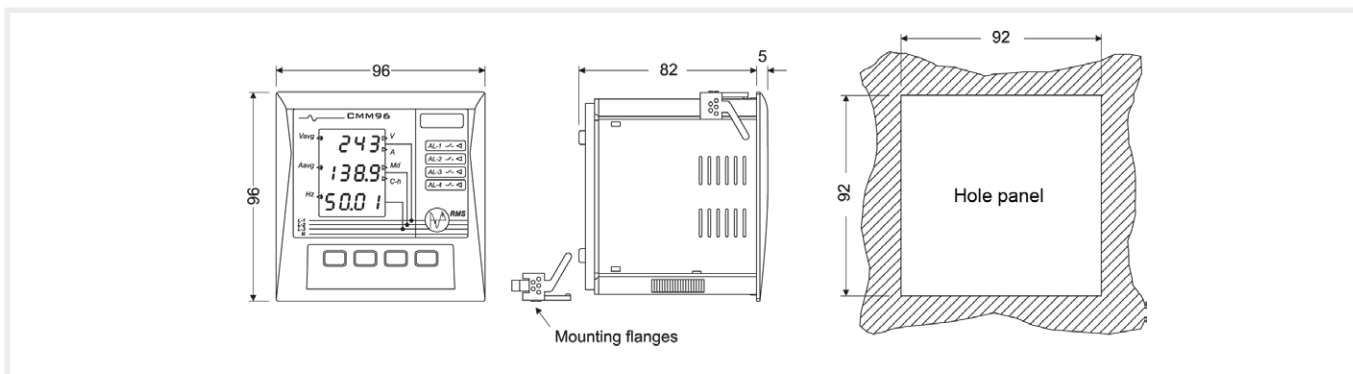

Connections

