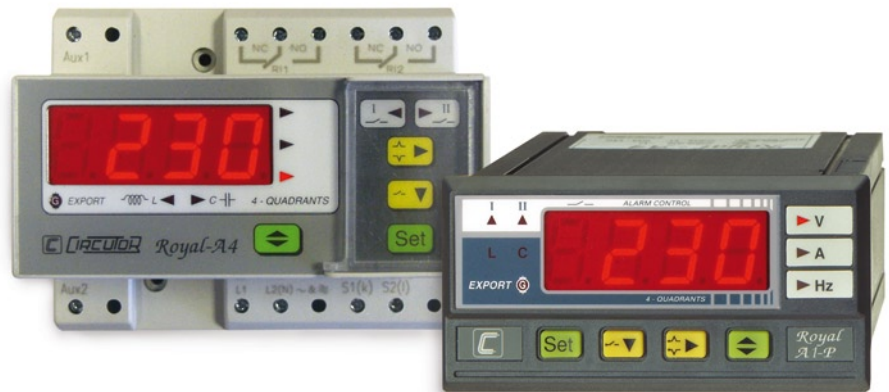

Digital indicator

Royal series

Digital indicator of various parameters for panel or DIN rail mounting

**Description**

- 4 digits, high luminosity
- Measurement in true root mean square (TRMS)
- Measurement in 2 or 4 quadrants (power generated and consumed)
- Valid for single and three-phase systems
- 2 built-in relay outputs
- Measurement of maximum and minimum values
- Fully programmable

Application

- Ideal for industrial environments, thanks to its compact and robust format
- Optional fail-safe operation

Features

	ROYAL A4	ROYAL A4-P	ROYAL A3
Power supply circuit	230 Vac ($\pm 15\%$)		
Frequency	40 ... 70 Hz		
Consumption	3 V·A		
Measurement circuit			
Scope	20 ... 500 Vac ... / 5 A		
Accuracy	0.5 % FE		
Overshoot (permanent / during 10 s)	1.2 U_n / 2 U_n		
Overload (permanent / during 10 s)	1.2 I_n / 5 I_n		
Consumption	0.25 V·A		
Frequency	40 ... 70 Hz		
Display	4 digits		
Scale excess indicator	" --- "		
Ambient conditions			
Storage temperature	-25 ... +70 °C	-25 ... +80 °C	
Operating temperature	0 ... +50 °C		
Relative humidity	-95% to 40 °C with no condensation		
Build features			
Box material	ABS VO Plastic		
Degree of protection	Box and terminals: IP 20 / Front panel: IP 52		
Weight	170 g		
Standards	IEC 1010, IEC 348, IEC 664, VDE 0435, VDE 0110		

References

Measurement	Parameters	Input	Digital	Size	Fixing	Type	Code
AC	V1n, V2n, V3n or V12, V23, V31	230 V _{p-N} / 400 V _{p-p}	2 relays	6 modules	DIN rail	ROYAL A3	M20332
AC	V, A, Hz, W, V·A, var, cos φ , MD, THD	... / 5 A	2 relays	6 modules	DIN rail	ROYAL A4	M20242
AC	V, A, Hz, W, V·A, var, cos φ , MD, THD	... / 5 A	2 relays	96x48x38	Panel	ROYAL A4-P	M20241

Digital instruments

ROYAL series

Digital indicator of various parameters for panel or DIN rail mounting



Coding table

M	2	X	X	X	X	0	0	X	X
Code						Internal Code			
Auxiliary power supply	Standard (230 V)					0			
	100 ... 120 V ac					1			
	380 ... 400 V ac					3			
	480 ... 500 V ac					4			
	18 ... 36 V dc					7			
	36 ... 72 V dc					8			
	40 ... 170 V dc					9			
Current input	Standard (... / 5 A)					0			
	... / 1 A					1			

Dimensions

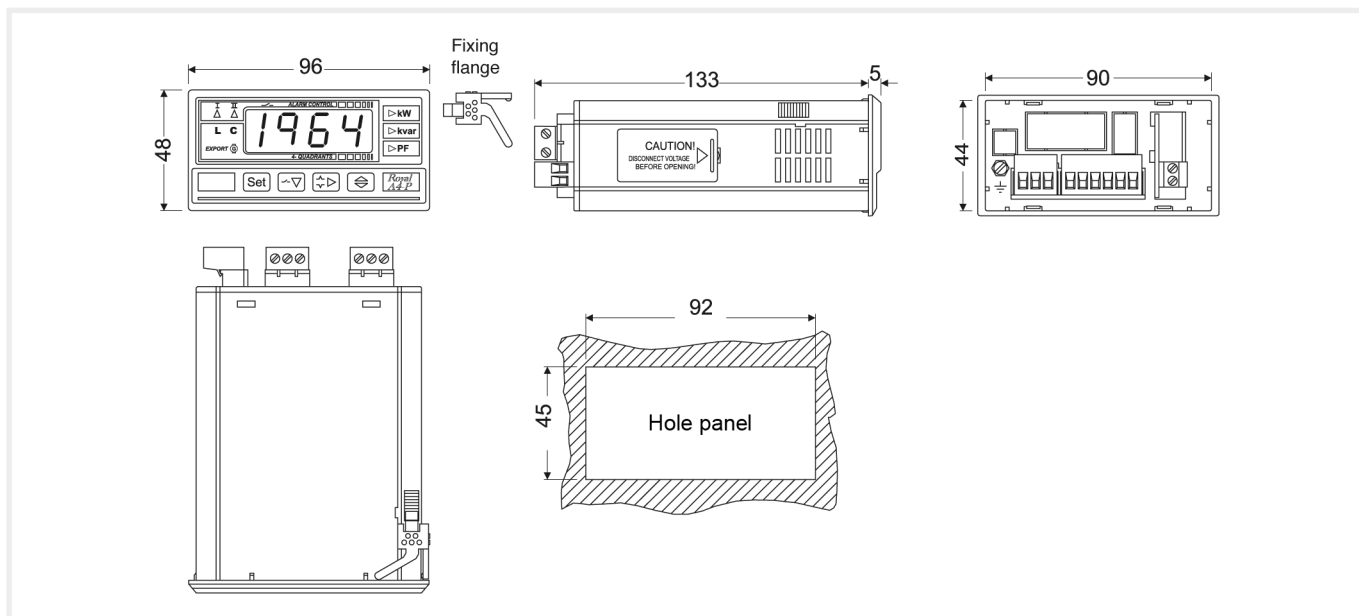

Connections

