



AUTOMATIC CAPACITOR BANKS
WITH DETUNED FILTERS
FR SERIES

INSTRUCTION MANUAL
Cod. 981 214 /99A-GB

INDEX

Subject	Page
1.- General description	2
2.- Types	2
3.- Technical characteristics	2
3.1.- General characteristics	2
3.2.- Technical characteristics of LC elements	3
3.3.- Dimensions	4
4.- Installation instructions for FR filters	4
4.1.- Initial checking (Before connecting to mains)	4
4.2.- Checking external connections (Before connecting to mains)	5
5.- Start up of FR filters	6
5.1.- PF regulator adjustments	6
5.2.- Start up: Connection to mains	6
6.- Trouble shooting	6
7.- Maintenance	7
8.- Technical service and warranty	7
9.- Electrical wire diagram	8
N° 945058 , FR6 at 230 V	9
N° 945068 , FR6 at 400 V	10
N° 945056/1 , FR12 at 230 V	11
N° 945056/2 , FR12 at 230 V	12
N° 945057/1 , FR12 at 400 V	13
N° 945057/2 , FR12 at 400 V	14

1.- GENERAL DESCRIPTION.

The **FR** capacitor banks are provided for the power factor compensation in installations having a high harmonic distortion contents. In such installations , and mainly at low load conditions , it is very usual to have resonances near the harmonic frequencies which produce harmonic amplification , thus causing overvoltages in the lines and overloads in the power factor equipment itself. Each group of an FR filter is equipped with a series reactor with an overall overvoltage factor generally adjusted at $p=7\%$. The assembly is also known as a detuned filter and avoids any possible resonance above 189 Hz by damping the existing harmonics. The FR series equipment allows a maximum of 12 groups of capacitor + filter reactor and includes the protection fuses and a PF regulator of the COMPUTER series. (See specific Instructions Manual for the PF regulator)

2.- TYPES

The full range of **FR filters** is detailed in the CIRCUTOR catalogue. The following table gives a resume

TYPES	Nr OF L – C GROUPS	MAX. STEP POWER		POWER RANGE	
		a 230 V / 50 Hz	a 400 V / 50 Hz	a 230 V / 50 Hz	a 400 V / 50 Hz
FRP-xxx	6	25 kvar	30 kvar	87,5 a 150 kvar	105 a 180 kvar
FR6-xxx	6	40 kvar	80 kvar	160 a 240 kvar	210 a 480 kvar
FR12-xxx	12	40 kvar	80 kvar	260 a 480 kvar	520 a 960 kvar

3.- TECHNICAL CHARACTERISTICS

The characteristics given below correspond to filters with a detuning factor $p=7\%$, but most of them are also applicable to other filters with 5% or 14%. The only difference consists of the L and C values.

3.1.- General characteristics.

Power supply	230 or 400 Vac , +10% , -20% (*)
Frequency	50 or 60 Hz
Ambient temperature	-10 / 45°C
PF regulator	COMPUTER series (see specific manual)
Maximum nr. of steps:	12
Protections:	
Fuses	Individual fuses set in each step
Thermostat	One in each reactor

Cabinets	(see figures 1 and 2)
Control board	Metal sheet , Epoxy painting , IP 31
L – C filter cabinet	Metal grid for cooling , Epoxy painting , IP 21
Types and weights	(See catalogue)
Dimensions	FRP types , L =980 mm , A= 520 mm , H= 2000 mm FR6 types , L =1100 mm , A= 800 mm , H= 1850 mm FR12 types use two FR6 cabinets
Accessories	Split core current transformers , TP series
Standards	EN 60.439 (IEC 439 , UNE 20 098) , IEC 664 , IEC 831 , UNE 20 010 , IEC 289 , VDE 100 , CSA 22.2 N°14

(*) Other values under request

3.2.- Technical characteristics of LC elements.

Tuning frequency (* Only for 7%)	189 Hz for 50 Hz networks 227 Hz for 60 Hz networks (others on request)
----------------------------------	--

Reactors

Core / Coil	High permeability metal sheet / Aluminium
Isolation voltage	2kV
Tolerance in L value	<3%
Saturation $\Delta L=5\%$	1,6 of rated current
Maximum ambient temperature	60°C
Internal temperature at I_{rated}	<110°C
Protection thermostat trip	90 °C
Total maximum overload $\Sigma(n.In)^2$	
Permanent	20%
Transient (1 min)	2 I_{rated}

Capacitors

Dielectric	Autoregenerable polypropylene
Working voltage	> 1,15 of rated U
Transient overload (10s)	1000 V
Isolation voltage against earth	3 kV
Maximum ambient temperature	max. 40°C
Losses	0,5W/kvar

3.3.- Dimensions

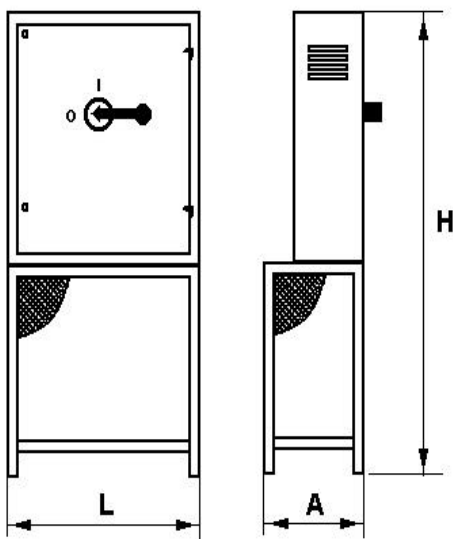

L =980 mm , A= 520 mm , H= 2000 mm

Fig. 1.- Cabinet for filters FRP

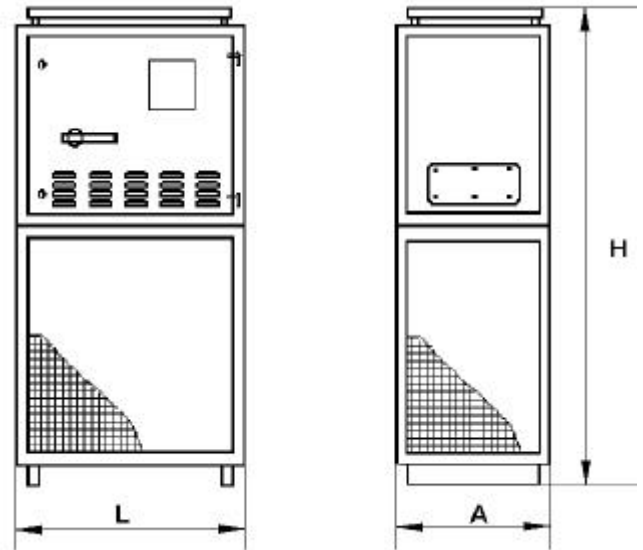

L =1100 mm , A= 800 mm , H= 1850 mm

Fig. 2.- Cabinet for filters FR6

NOTE: The types FR12 use two identical cabinets

4.- INSTALLATION INSTRUCTIONS FOR FR FILTERS

4.1.- Initial checking (Before connecting to mains)

To get a satisfactory behaviour of the **FR** and **FRP** detuned filter capacitor banks , the following installation conditions must be followed:

- Place the equipment so that there is enough space between the cabinet walls and the building walls and roof , specially in the area close to cabinet cooling grids. Minimum clearances must guarantee enough air circulation to get good **cooling** conditions.
- Avoid placing the FR cabinets close to heat sources. The maximum ambient temperature in the cabinet vicinity must be below 40°C. Take care that the cabinet is not exposed to sun radiation , either outside or inside a room.
- Check that the rated voltage of the FR equipment , indicated in the characteristics plate , is compatible with the available supply at the site of installation.
- Check that the kvar rating of the FR equipment corresponds to the needs at the site.

4.2.- Checking external connections (Before connecting to mains)

- All the external connections have to be made through the **FR** terminals.
- Connect the power cables to the terminals **L1, L2 y L3** . In standard FR equipment there is no need of connection to neutral. The power cables must be sized according to FR power rating.
- Do not forget the earth connection to the terminal provided for this purpose.
- A current transformer (**CT**) **must be placed externally** to measure the PF. The CT measures the current in one of the power cables. The phase where the CT is placed is usually connected to L1 at the FR input.
- **IMPORTANT!** , the CT must be placed so that it measures the total current of load + FR capacitor bank. (See the right CT location in figure 2)

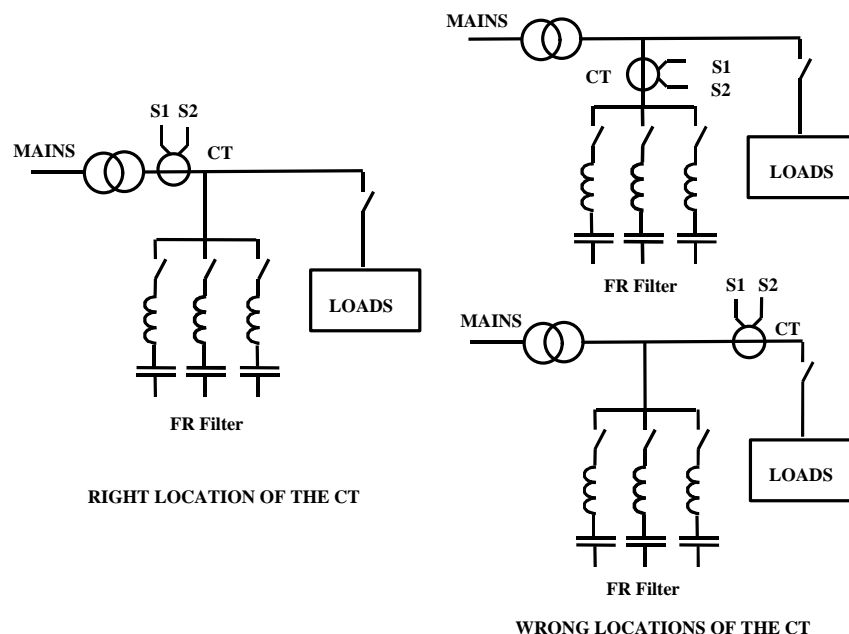

FIGURE 2.- Location of the current transformer (CT)

- Check the connections of the PF regulator relative to the phase where the CT is connected. It is recommended to connect the cables at the power terminals L1, L2 and L3 as follows: Cable at L1 coming from the phase where the CT is placed. The PF regulator , COMPUTER , is then supplied from the other two phases L2 and L3 (see electrical wire diagrams). For details on PF regulator adjustment see the specific manual for such device.
- Check that the COMPUTER PF regulator has been properly connected (230 or 400V) according to the supply voltage phase to phase.

5.- START UP OF FR FILTERS.

During the start up of FR filters , the following procedures must be followed:

5.1.- PF regulator adjustments

- Set the adjustments of primary current at the CT , I_p , the current of the first step capacitor , I_{C1} , the CT “Phase” , the alarm relay , etc. According to the COMPUTER PF regulator instructions manual.
- The PF ($\cos \phi$) adjustment must be usually set to 1.
- Select , in the COMPUTER PF regulator settings, the suitable program 1:1:1 (all capacitors equal) or 1:2:2 (1st step half the power of the others) or 1:2:4 .
- The recommended settings for the distortion alarm, $d\%$, are : Between 25 and 30% in case of high short circuit power , S_{cc} , and between 15% and 20% for low S_{cc} .

5.2.- Start up: Connection to mains

; ATTENTION! For service purposes switch OFF the equipment. After that, a safety time of 3 minutes must elapse before any manipulation inside the equipment to allow the discharge of the capacitors.

6.- TROUBLE SHOOTING.

The capacitor bank will only operate if there are some loads which need PF compensation. If the equipment does not operate properly in such conditions check the following points:

- If the alarm LED on the PF regulator is lighting or the display does not light , check the supply voltage and the fuses (both power and control fuses)
- If the LED signing C in the COMPUTER lights , indicates that the PF regulator appreciates a capacitive load. If inductive load is expected , check the connections of the CT and the PF regulator adjustments (see COMPUTER manual)
- The number of connected steps may be seen in the PF regulator display (see PF regulator manual). Notice that in case of programs 1:2:2 or 1:2:4 , the capacitors having a power of $2.P1$ or $4.P1$ ($P1$ = Power of the 1st step) are counted as 2 or 4 steps. Check that the number of connected steps coincides with the Nr. of steps shown by regulator.
- If there are some inactive steps and the PF regulator shows a lack of compensation , check the settings of such regulator.
- Once the normal operation is achieved , check if the current consumption of each step is correct, according to its rated power (Current shown in characteristics label). An excess of consumption may be due to an excess of supply voltage or to the presence of harmonics.

- In case of a faulty operation which may not be solved with the above indications, contact the CIRCUTOR S.A. technical service

¡IMPORTANT!

After approximately 1 hour working at full load it is recommended to measure the temperature at the capacitor walls and at the reactors iron core. The first must be below 60°C and the second below 85°, otherwise check the cooling conditions.

7.- MAINTENANCE.

Yearly inspection:

Check the equipment visually and check the temperature of the capacitors and the reactors

- Check that all the steps operate when necessary. Otherwise check the fuses and the supply voltage.
Check that the current of each step is in accordance with its labelled value. A higher current may be due to wrong supply voltage or to the presence of harmonics. A low current may indicate a faulty capacitor.
- Check that there are not loose connections at the terminals.

8.- TECHNICAL SERVICE AND WARRANTY

All CIRCUTOR products are covered by a warranty of 1 year from the delivery in case of any manufacturing default. The warranty does not cover the protection elements like fuses or other neither the elements subject to ageing in normal service.

This warranty will not be applicable in case of wrong manipulation or in case that the rules of installation have not been respected.

CIRCUTOR offers to all its customers the assistance of its TECHNICAL AND ENGINEERING STAFF

ELECTRICAL WIRE DIAGRAMS