



COMPUTER 6f / 12f

INSTRUCTION MANUAL

Cod. M 981168 / 97-02

INDEX

1.- General information	3
2.- Technical characteristics	3
3.- Display indications and setting controls	5
3.1.- Display indications	5
3.2.- Setting and adjustment controls	6
4.- Installation and start up of COMPUTER 6f	8
4.1.- Initial chec	8
4.2.- Adjustments	10
4.3.- Manual adjustment of C/K factor	10
4.4.- Automatic adjustment of C/K factor	12
4.4.- Tieme between steps and reconnection time	13
5.- Trouble shooting	14
6.- Maintenance	15
7.- Technical service and warranty	15

M 981168/97-02

1.- GENERAL INFORMATION

The COMPUTER 6f is a fast response power factor regulator provided for the control of capacitor banks operated by means of static switches (based on thyristors)

In applications where there are large and fast fluctuations of the load current, the response times of a conventional system are excessive to obtain a suitable power factor regulation. In such cases, capacitor banks operated by means of static switches (thyristors), which are able to make several operations in one second, must be provided. The ON and OFF switching of these static capacitor banks is performed at zero voltage crossing and at zero current, thus eliminating all the possible transients (see CIRCUTOR EK series of static capacitor banks and EM modules). To control these kind of capacitor banks a fast response PF regulator, able to measure and operate in a few milliseconds must also be provided. This is the function of the microprocessor based COMPUTER 6f, designed with the last techniques in microelectronics, including static optocoupled outputs and with a high response speed to the reactive power demands, which may reach the 80 ms per step.

2.- TECHNICAL CHARACTERISTICS

Voltage Circuit

Supply Voltage	230 /400 Vac; 50 or 60 Hz ; +10% , -15%
Consumption	6 VA
	(Other voltages or frequencies on request)

Current Circuit

Rated current	$I_n/5A$
Permanent overload	1,2 I_n
Consumption	0,5 VA
C/K ratio adjustment	0,05 a 1 A

Outputs

Number / Type of outputs	6 / Static MOS, bi-directional
Maximum ratings	200 Vdc / 130 Vac ; 80 mA dc or ac
Response delay (Tr)	Adjustable (80 , 160, 400 ó 800 ms)

Other characteristics

Cos ϕ adjustment range	0,85 Ind. a 0,95 Cap
Programs	1:1:1 and 1:2:2 ; (1:2:4 on request)
Connection	Plug-in terminals
Working temperature	0 / 50°C
Protection degree	IP-41
Dimensions (see fig)	144 x 144 mm
Weight	1,00 kg

STANDARDS

EN 61010-1 , IEC 1010-1, IEC 414, , IEC 255, UL 94, UNE 21.349, UNE 20.553, UNE 21.136, VDE 0110

3.- DISPLAY INDICATIONS AND SETTING CONTROLS

The COMPUTER 6f regulator has a numerical display and the following control elements (see figure 1)

3.1.- Display indications:

A-B	Numerical Display	In normal conditions shows the $\cos \varphi$: example 95 means that the cosinus of phase angle is 0,95 The sign "--" indicates that the current measured through the CT is below the sensitivity limit (no capacitors connected in this situation) The sign "⊖" means that the CT is not properly connected (wrong phase or S1-S2 reversed , this sign appears only when automatic adjustment of C/K is performed , see paragraph 4.4)
D	LED	Lights ON when the measured $\cos \varphi$ is inductive.
E	LED	Lights ON when the measured $\cos \varphi$ is capacitive.
F	LED	This LED lights ON when the button C is pushed and the display A-B shows the number of connected steps

3.2.- Setting and adjustment controls:

C	Push Button	When pushed the display shows the number of connected steps (If programs 1:2:2 or 1:2:4 are used, the capacitor groups having a power $2Q_1$ or $4Q_1$, count as 2 or 4 steps respectively)
G	Push Button	Manually increases the number of connected steps (See note)
I	Push Button	Manually decreases the number of connected steps (See note)
J	cos ϕ Setting	Allows the setting of desired $\cos \phi$ (the adjustment range goes from 0,85 lag to 0,95 lead)
K	C/K Setting	Allows the setting of the reactive current threshold for connection or disconnection of capacitor steps. (See paragraphs 4.3 and 4.4)
L	Program Selector	Allows the change from program 1:1:1 to 1:2:2. For 1:2:4 program, use special COMPUTER 6f type.
M	Nr. outputs Selector	Selection of the number of used outputs (= number of capacitor blocks of the equipment).
C+I	Supply test	Pushing these two buttons the LEDs D, E and F show whether the voltage is high, low or OK.
C+G	Automatic C/K setting	Pushing C and G simultaneously allows the automatic setting of C/K factor (only in absence of load, see paragraph 4.4)

NOTE: There is a delay of approximately 2 s/step. The time depends on the time that the step has been inactive.

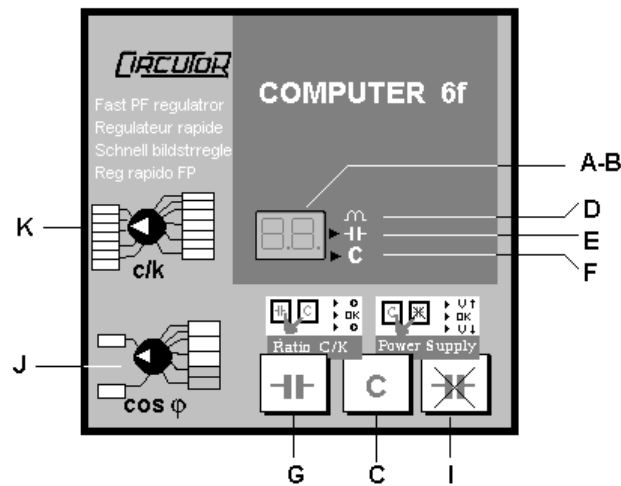

Figure 1.a).- COMPUTER 6f: Control and adjustment elements

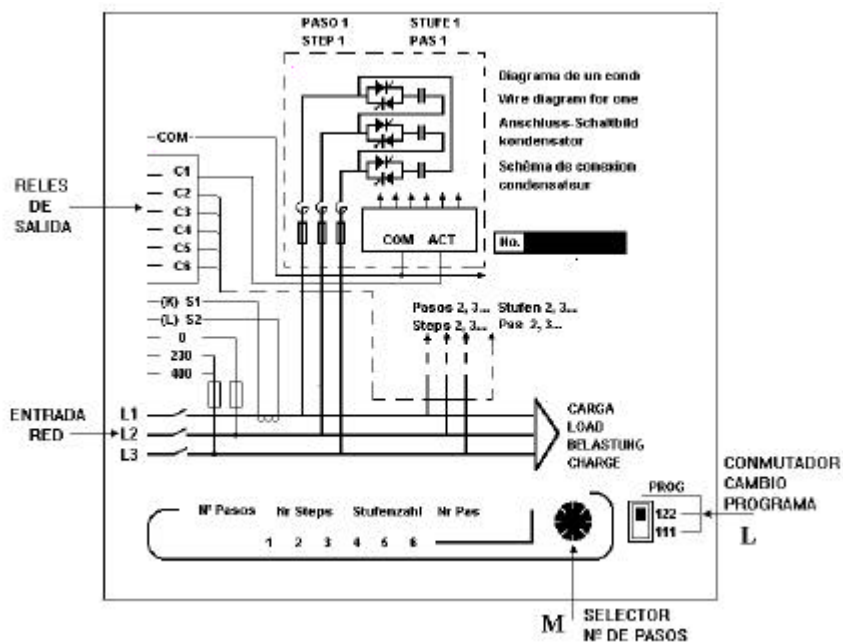

Figure 1.b).- COMPUTER 6f: Control and adjustment elements

4.- COMPUTER 6f INSTALLATION AND START UP.

To install and start up a static switched capacitor bank , follow the instructions indicated in the corresponding manual. This manual gives the specific instructions for the fast PF regulator start up (supposed it acts on a static switched bank)

4.1.- Initial check (Before the connection to supply)

- The COMPUTER 6f, has three terminals for supply input, identified as 0, 230, 400. The indication corresponds to the rated input voltage. Check that the PF regulator has been connected according to the rated voltage of the equipment , usually indicated in the plate of characteristics.
- The PF regulator must read the current of the installation through a current transformer (CT). The capacity of such CT must be above the maximum expected current in the installation, and the rated secondary signal must be 5A.
- The section of the cables connecting the secondary side of CT to the PF regulator must be enough to keep the voltage drop within reasonable limits despite the line length.
- **The supply voltage for the PF regulator must always be taken from the phases distinct of that having the CT.**
- According to previous paragraph, the CT must be placed in the phase distinct of those where the supply voltage is taken and measuring the total current of load+capacitor bank. (See the correct position of CT in figure 2)
- Check that the connections of the PF regulator with the rest of devices of the static capacitor bank are according to figure 3.

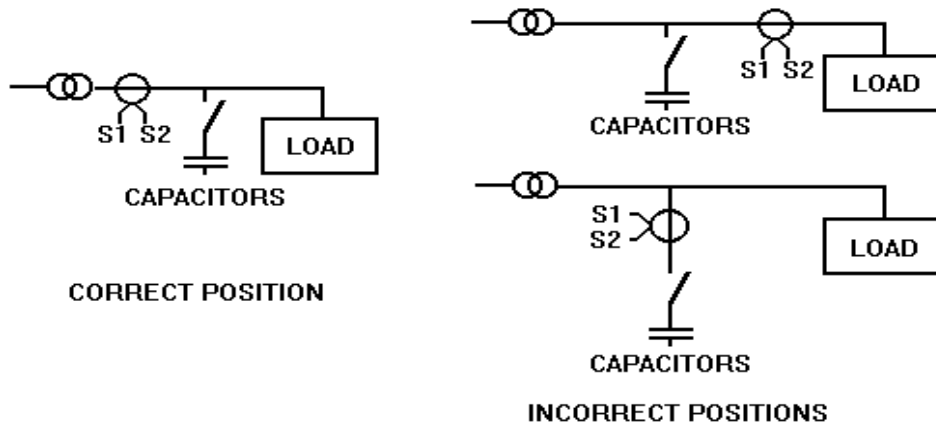

Figure 2.- Position of the current transformer

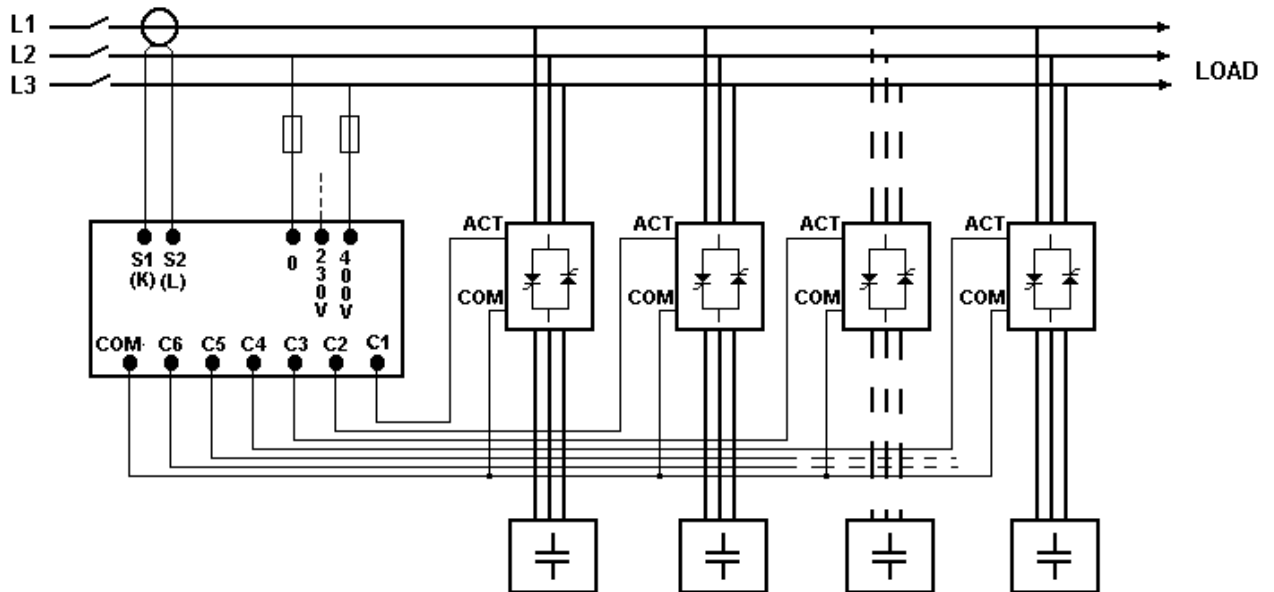

Figure 3.- Connection of COMPUTER 6f to capacitor bank

4.2.- Adjustments .



The *COMPUTER 6f* will only recognize the change of its settings after a *RESET*, which may be obtained by removing momentarily the supply voltage (except the *cos φ* and the *C/K* potentiometers which are recognized immediately)

- The *cos φ* potentiometer must usually be set to 1.
- By means of **L** switch , on the rear side (see figure 1b) , select the program 1:1:1 or 1:2:2 depending on the power of the capacitor steps. If program 1:2:4 is needed , a special type of *COMPUTER 6f* must be used (on request)

PROGRAM	POWER CAPACITORS
1:1:1:1	All having the same rated power.
1:2:2:2	First step power is 1/2 the power of the others.
1:2:4:4 (special)	First step power is 1/2 the power of the 2nd step Second step has 1/2 the power of each of the following steps

- By means of switch **M** (see figure 1b) select the total number of outputs (Number of static switches or capacitor groups to be driven. It doesn't matter the power of each capacitor)
- By means of **K** knob (see figure 1), adjust the *C/K* factor. The adjustment value depends on the rated power of the smallest capacitor in the bank and on the primary/secondary ratio of the current transformer. The adjustment of the *C/K* factor may be performed in two ways:

4.3.- Manual adjustment of the *C/K* factor.

- Before adjusting, the *C/K* factor must be calculated as follows:

$$C / K = \frac{1000 \cdot Q(k \text{ var})}{1,73 \cdot U_c \cdot I_p / I_s}$$

where: $Q(\text{kvar}) = \text{kvar of the smaller capacitor step}$

$U_c = \text{phase to phase voltage}$

$I_p/I_s = \text{current transformer ratio (example: for a 1000/5 CT}$
 divide 1000 by 5 , the value $I_p/I_s = 200)$

- The C/K value may also be obtained from tables 1 and 2 , which give the factor value for different voltages, CT ratios and kvar values of the smaller capacitor.

TABLE 1.- C/K values for lines at 400V (phase to phase)

CURRENT TRANSF	CAPACITOR POWER (Smaller step in kvar)						
	10	20	30	40	50	60	80
150/5	0,48	0,96					
200/5	0,36	0,72					
250/5	0,29	0,58	0,87				
300/5	0,24	0,48	0,72	0,96			
400/5	0,18	0,36	0,58	0,72	0,87		
500/5	0,14	0,29	0,45	0,54	0,72	0,87	
600/5	0,12	0,24	0,36	0,48	0,60	0,72	0,96
800/5	0,09	0,18	0,27	0,36	0,45	0,54	0,72
1000/5	0,07	0,14	0,22	0,29	0,36	0,43	0,57
1500/5	0,05	0,10	0,14	0,19	0,24	0,29	0,38
2000/5		0,07	0,11	0,14	0,18	0,22	0,28
2500/5		0,06	0,09	0,12	0,14	0,17	0,23
3000/5		0,05	0,07	0,10	0,12	0,14	0,19
4000/5			0,05	0,07	0,09	0,11	0,14

TABLE 2.- C/K values for lines at 230V (phase to phase)

CURRENT TRANSF	CAPACITOR POWER (kvar , of lower step)						
	5	10	15	20	30	40	60
150/5	0,42	0,84					
200/5	0,31	0,63	0,94				
250/5	0,25	0,50	0,75	1,00			
300/5	0,21	0,42	0,63	0,84			
400/5	0,16	0,31	0,47	0,63	0,94		
500/5	0,13	0,25	0,38	0,50	0,75	1,00	
600/5	0,10	0,21	0,31	0,42	0,63	0,84	
800/5	0,08	0,16	0,24	0,31	0,47	0,63	0,94
1000/5	0,06	0,13	0,19	0,25	0,38	0,50	0,75
1500/5		0,08	0,13	0,17	0,25	0,33	0,50
2000/5		0,06	0,09	0,13	0,19	0,25	0,38
2500/5		0,05	0,08	0,10	0,15	0,20	0,30
3000/5			0,06	0,08	0,13	0,17	0,25
4000/5			0,05	0,06	0,09	0,13	0,19

4.4. Automatic adjustment of C/K factor.



Notice that to perform the automatic adjustment, all the loads must be disconnected

- In no load conditions, push simultaneously the buttons **G** and **C**. After doing that, the COMPUTER will operate and connect the smallest capacitor step , the display shows the sign "I" and one of the LEDs **D**, **E** or **F** will light.
- The correct setting for the C/K knob (**K**) is obtained when the LED **E** is lighting. In case that D lights on turn the knob clockwise and if the sign F lights, turn it counterclockwise.
- If the display shows the sign E^{\dagger} , means that it is not possible to get the right adjustment: The cause may be that the CT is wrongly installed, placed in the wrong phase or its terminals S1 and S2 are reversed (Try to interchange)

4.5.- Time between steps and reconnection time for a C.

The operating time of the COMPUTER 6f may be adjusted according to the load needs. Certain applications really require a very short response time, but sometimes (mainly if the current wave has a high distortion) the PF regulator makes more operations than necessary.

The response time between steps, T_r , may be adjusted by means of two internal jumpers, placed at the main printed circuit board, as shown in figure 4 and table. The time between disconnection and a new connection of a step, T_s , is always set at $5 T_s$.

The default values when COMPUTER 6f is delivered are $T_r = 160$ ms and $T_s = 0,8$ s. These times use to be adequate for most of the cases.

If the load is switching ON and OFF every two or three mains cycles, change T_r to 80 ms, but if unnecessary operations are observed, then adjust the time to a higher value.

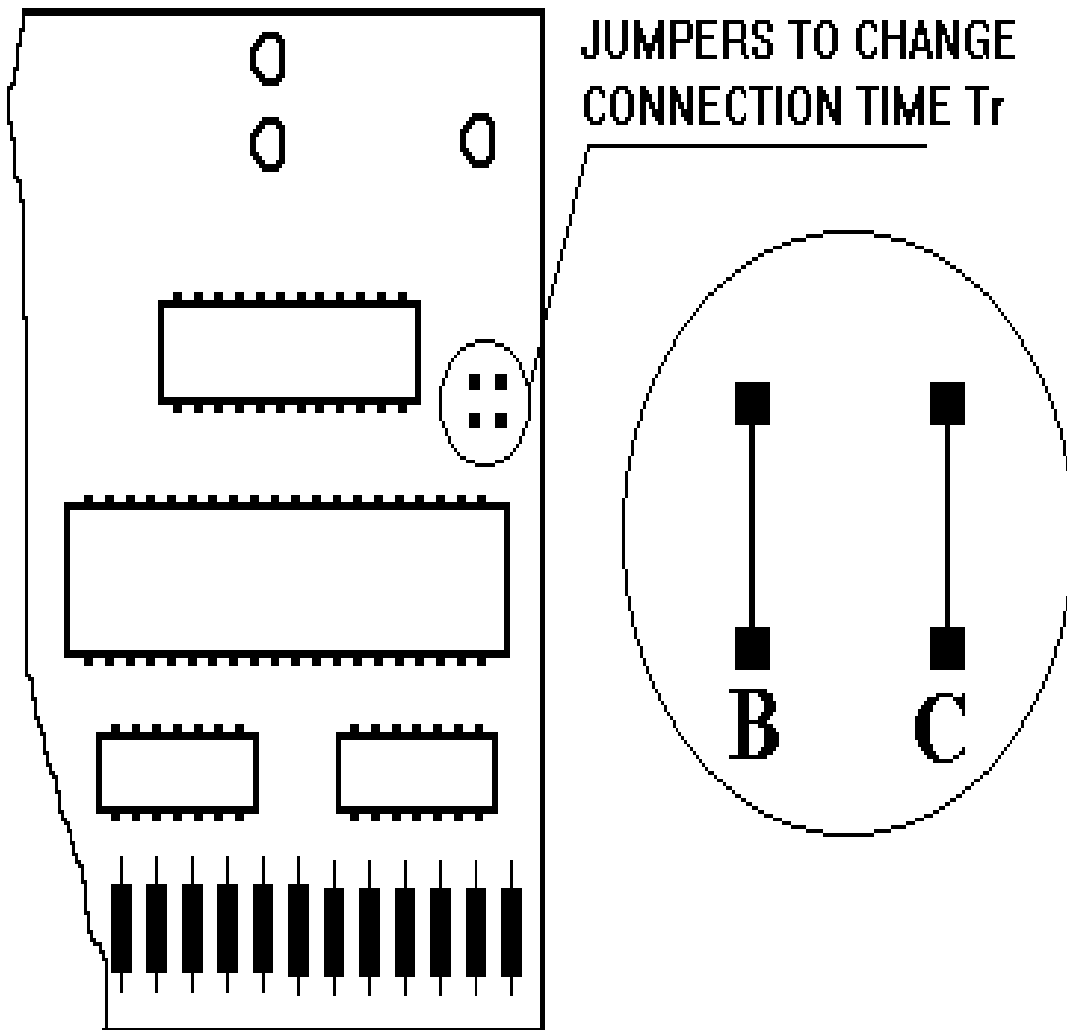

JUMPERS TO CHANGE CONNECTION TIME T_r

COMPUTER 6f MAIN PCB

JUMPERS / TIMES			
B	C	Tr (ms)	Ts (s)
YES	YES	80	0,4
YES	NO	160	0,8
NO	YES	400	2
NO	NO	800	4

Figure 4.- Jumpers for operation time adjustment

5.- TROUBLE SHOOTING.

Notice that the capacitor bank should operate only if there is a minimum load. If the equipment does not work properly check the following points:

- If the display of the COMPUTER 6f does not light or gives a very slight bright , check the supply voltage and the fuses (power and control fuses)
- If the display shows the sign -- means that the COMPUTER 6f sees a current below the minimum threshold. Check the CT connections and the C/K adjustment.
- If the display shows a numerical value and the LED **F** , pointing to the letter **C** is lighting , means that the COMPUTER 6f sees a capacitive load. If the expected is an inductive load then check the CT connections (Try to reverse the wires connected to terminals S1-S2)
- During normal operation the number of connected steps may be displayed by pushing the key **C** in the COMPUTER front panel. Notice that in case of using programs 1:2:2 or 1:2:4 , the capacitors having a power of 2xP1 or 4xP1 (P1= Power of the 1st step) are displayed as 2 or 4 steps.
- Check that the number of connected steps coincides with the Nr. of steps shown by the display. See the LEDs in the static switches to check that point.
- If one of the steps is never connected check the wiring between the COMPUTER and the static switch.
- If there are some inactive steps and the display shows a lack of compensation , check the settings of the COMPUTER.
- In case of a faulty operation which may not be solved with the above indications , contact the CIRCUTOR S.A. technical service.

6.- MAINTENANCE.

6.1.- Yearly inspection:

- Inspect the equipment visually and check the temperature of the capacitors and the thyristor heat sinks.
- Check that all the steps operate when necessary. Otherwise check the fuses.
- Check that the supply voltage is within the limits.
- Check that the current of each step is in accordance with its labeled value. A higher current may be due to the presence of harmonics. A low current may indicate a faulty capacitor.
- Check that there are not loose connections at the terminals.

7.- TECHNICAL SERVICE AND WARRANTY

All CIRCUTOR products are covered by a warranty of 1 year in case of any manufacturing default . The warranty does not cover the protection elements like fuses or other neither the elements subject to aging in normal service.

This warranty will not be applicable in case of wrong manipulation or in case that the rules of installation have not been respected.

CIRCUTOR offers to all its customers the assistance of its TECHNICAL AND ENGINEERING departments.

REMARKS:

1.- This manual is also valid for the fast PF regulator COMPUTER 12f . The COMPUTER 12f is an enhanced version of COMPUTER 6f having 12 static outputs, thus allowing a maximum of 12 steps in program 1:1:1 , 23 steps with program 1:2:2 and up to 43 steps in program 1:2:4