



ABSORPTION FILTERS

FAP SERIES

INSTRUCTION MANUAL

Cod. M - 981216 - 01A

1 INTRODUCTION

Absorption filters are designed to sink a significant part of harmonics present at a certain point of an electrical network. The working principle consists in absorbing the harmonic currents generated by certain loads, so that the high frequency currents do not flow upstream and do not affect neighbouring loads.

2 CONFIGURATION

An absorption filter consists of several groups of reactance in series with a capacitor, placed in a suitable cabinet. Each group (also called step) is characterized by three main parameters

1) Harmonic frequency to be filtered, 2) Maximum current to sink and 3) Reactive power delivered at fundamental frequency, 50 or 60Hz.

To be effective, an absorption filter must include a choke reactor in series with the load which separates it from other external loads which will not be filtered (See figures 1 and 2). The choke reactor is not necessary if all the loads downstream of a transformer must be filtered. In this case the transformer leakage reactance does the job.

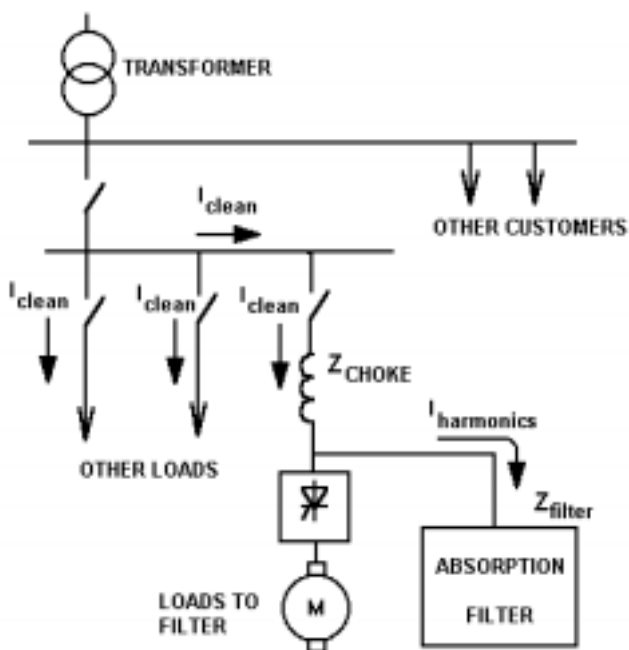

Figure 1.- Absorption filter, separated from the rest of loads by a choke reactor.

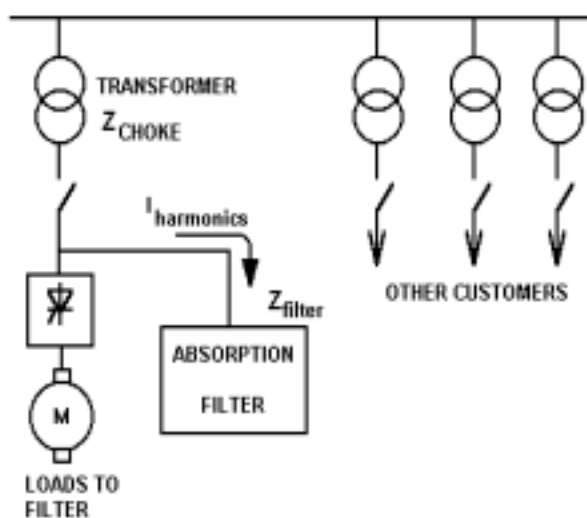

Figure 2.- Absorption filter, separated from the rest of loads by a transformer.

3 TYPES

This manual is concerned with low power absorption filters, called FAP series. See also FA filters for higher power ratings. Table 1 gives a list of FAP types depending on the main current and on the ripple current to be absorbed. All FAP types consist of 2 steps dedicated to 5th and 7th harmonics and include the series choke reactor. They are intended to be connected fix to the line to be filtered (see schematics in section 4)

Table 1. Standard FAP filters for 50 /60 Hz networks

TYPE (*)	SUPPLY (V)	I max (A)	Main CB (A)	FREQ (Hz)	FILTERED CURRENT STEPS x (A)	Q STEPS x (kvar)
FAP50-400-10-2x6,5	400	10	20	50	2 x 6,5	2 x 3,5
FAP50-400-20-2x13	400	20	40	50	2 x 13	2 x 7
FAP50-400-30-2x13	400	30	50	50	2 x 13	2 x 7
FAP50-400-40-2x20	400	40	63	50	2 x 20	2 x 10,5
FAP50-400-50-2x20	400	50	63	50	2 x 20	2 x 10,5
FAP60-400-10-2x5,5	400	10	20	60	2 x 5,5	2 x 4
FAP60-400-20-2x11	400	20	40	60	2 x 11	2 x 8
FAP60-400-30-2x11	400	30	50	60	2 x 11	2 x 8
FAP60-400-40-2x17	400	40	63	60	2 x 17	2 x 12,5
FAP60-400-50-2x17	400	50	63	60	2 x 17	2 x 12,5

(*) Other types with different voltage or currents on request

4 SCHEMATICS

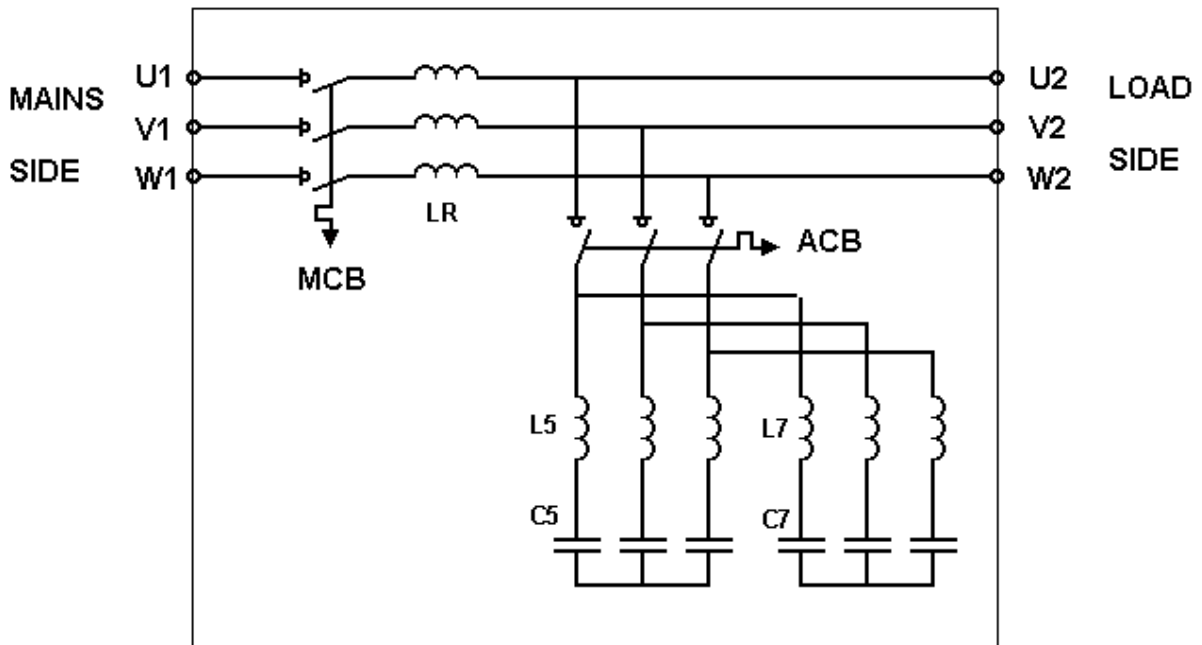

5 TECHNICAL CHARACTERISTICS

The technical characteristics given below apply to all the standard FAP filter types. Nevertheless there may be several optional features concerning, the protection devices or other functional details.

5.1 General technical characteristics.

Table 2.- Technical characteristics

Standard supply voltages..	400V (1)
Frequency	50 Hz or 60 Hz
Ambient temperature	-10 to +45 °C
Main Circuit Breaker (MCB)	Circuit breaker. Size acc. To table 1
Filter protection ACB	Circuit breaker. Same size as MCB
Filter cabinet: Protections cubicle	600 x 300 x 800 mm . Epoxy painted metallic sheet IP22
Standards	IEC-61642 , EN-60439, IEC-664 , EN-60831 , EN-60289
(1) Other supply voltages on request	

5.2 Technical characteristics of L-C sets.

Table 3.- Characteristics of L – C filtering groups

	Tuning frequency	$1,05 f_h$
Reactor		
	Core / Windings	Oriented grain magnetic sheet / Copper
	Isolation voltage	2kV
	Tolerance in L value	<3%
	Saturation $\Delta L=5\%$	$1,6 I_{nominal}$
	Max. ambient temperature	50°C
	Internal temperature at I_{nom}	<110°C
	Max allowed overload. $\Sigma(n.I_n)^2$	
	Permanent	20%
	Transient (1 min.)	2 $I_{nominal}$
Capacitor		
	Dielectric	Self-healing polypropylene
	Rated voltage	$1,15 U_{nominal}$
	Transient overload (10s)	1000 V
	Isolation vs. ground	3 kV
	Max. Ambient temperature	Max. 40°C
	Losses	0,5W/kvar

5.3 Dimensions and lay-out:

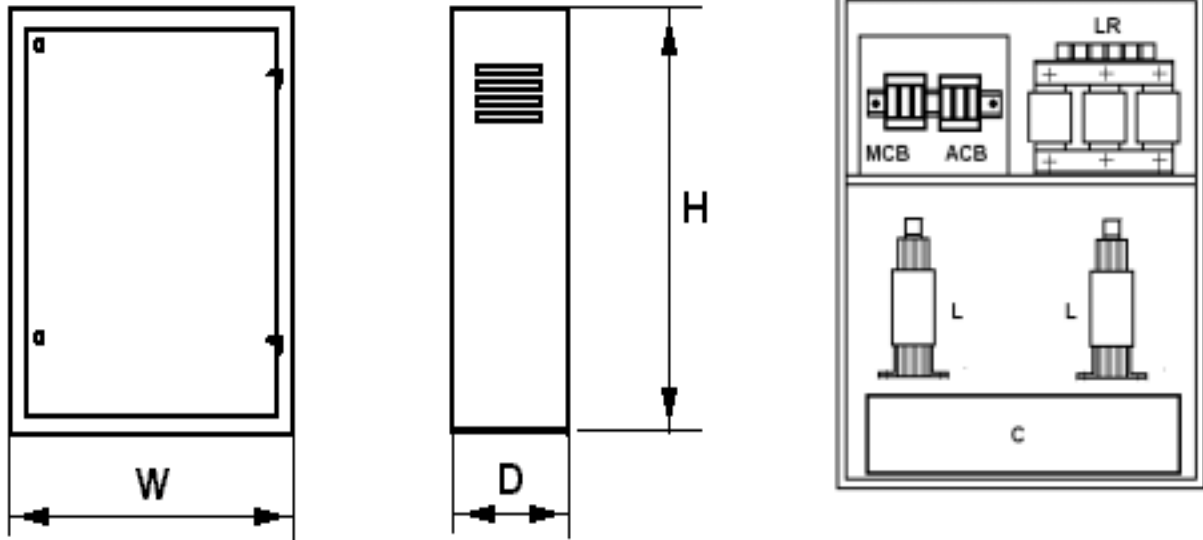

W x D x H = 600 x 300 x 800 mm

FILTER LAYOUT

6 INSTRUCTIONS FOR FA FILTERS INSTALLATION.

6.1 Initial checking (Before connecting to supply voltage)

To guarantee a good behaviour and prevent against premature ageing of **FAP** filters, the following installation rules must be respected.

- For installation, the main circuit breaker , MCB , must be OFF
- Take care of the **cooling** conditions. Allow the necessary space between the cabinet walls and the building walls , so that a good air circulation is guaranteed for cooling.
- FAP equipment should not be installed close to heat sources. The maximum ambient temperature should not be higher that 40°C. As a particular case, FAP equipment should not be directly exposed to sun radiation.
- Check the nominal voltage of FAP equipment, which is indicated in the characteristics plate. It should coincide with the voltage at the site to be connected.
- Check that the configuration (number of steps and rated current of each) are according to the needs of the network where the FAP has to be installed.

6.2 Checking the external connections (Before connecting to supply voltage).

All the external connections must be done at the terminals placed at the top of **FAP** cabinet.

- Connect the supply three phase power cables at the power terminals **U1, V1 and W1** . There is no need to connect the neutral.
- Connect the loads at the output side , terminals **U2, V2 and W2**
- Connect the earth cable to the earth terminal (signed with the corresponding symbol)

7 START UP OF FAP FILTERS

For the start-up of FAP filters, the following steps must be followed (see schematics in section 4)

- Start the equipment by switching ON the auxiliary circuit breaker ACB and the main MCB
- Check that the current consumption of the different steps is within the tolerance limits (use a current clamp giving true RMS value). Notice that in case that there are no harmonics to sink, the current may be below the rated value.

¡ ATENTION!

- Before any manipulation for service purposes, disconnect the ACB. In this situation the filter section may be repaired without interruption of service at the load. Before starting the manipulation for servicing, wait for at least 5 minutes to allow the capacitors to discharge

8 TROUBLE SHOOTING.

In case that the FAP filter presents an abnormal behaviour when connected to mains, check the following points.

- Check the current of each step. Under normal conditions it must be within the rated values. Use a true RMS current clamp
- In case that some trouble cannot be solved by checking the previous steps, contact the CIRCUTOR technical service department.

¡IMPORTANT!

- Once the permanent conditions have been reached (after 1 hour working) check the temperature at the capacitors and at the reactor core (iron). Capacitors must be below 60°C and iron at the reactors must be below 85°C. In case of higher temperatures check the cooling of cabinet.

9 MAINTENANCE

Yearly inspection:

- Check visually if there are some visible defaults in the equipment.
- Check the temperature at the capacitors and reactors as in paragraph 8.
- Check the current in each step. It must be within the rated limits. In case that the current is higher than nominal, it may be a symptom that the filter power is not enough to sink the ripple current. In this case the filter must be upgraded.
- Check that there are no lose power terminals producing hot contacts.

10 TECHNICAL SERVICE AND WARRANTY.

All CIRCUTOR products are covered by a warranty of 1 year from the delivery in case of any manufacturing default . The warranty does not cover the protection elements like fuses or other neither the elements subject to ageing in normal service.

This warranty will not be applicable in case of wrong manipulation or in case that the rules of installation have not been respected.

CIRCUTOR offers to all its customers the assistance of its TECHNICAL AND ENGINEERING STAFF