



ABSORPTION FILTERS

FA SERIES

INSTRUCTION MANUAL

Cod. M-981215 - 01A

INDEX

1.- INTRODUCTION.....	2
2.- CONFIGURATION.....	2
2.- TYPES.....	2
2.1.- ACCORDING TO THE FILTER CONFIGURATION.....	3
2.2.- ACCORDING TO THE CONTROL METHOD.....	3
3.- TECHNICAL CHARACTERISTICS.....	4
3.1.- GENERAL TECHNICAL CHARACTERISTICS.....	4
3.2.- TECHNICAL CHARACTERISTICS OF L-C SETS.....	5
3.3.- DIMENSIONS.....	6
4.- INSTRUCTIONS FOR FA FILTERS INSTALLATION.....	6
4.1.- INITIAL CHECKING (BEFORE CONNECTING TO SUPPLY VOLTAGE).....	6
4.2.- CHECKING THE EXTERNAL CONNECTIONS (BEFORE CONNECTING TO SUPPLY VOLTAGE).....	6
5.- START UP OF FA FILTERS.....	7
5.1.- MANUAL CONTROL TYPES FA.../M.....	7
5.2.- AUTOMATIC CONTROL TYPES. FA.../A.....	8
6.- TROUBLE SHOOTING.....	8
7.- MAINTENANCE.....	9

1.- INTRODUCTION

Absorption filters are designed to sink most of the current harmonics present at a certain point of an electrical network. The working principle consists on absorbing the harmonic currents generated by certain loads, so that , this current does not flow upstream and does not affect to neighbouring loads.

2.- CONFIGURATION

An absorption filter consists of several groups of reactance in series with a capacitor, placed in a suitable cabinet. Each group (also called step) is characterized by three main parameters

1) Harmonic frequency to be filtered , 2) Maximum current to sink and 3) Reactive power delivered at fundamental frequency, 50 or 60Hz.

To be effective, an absorption filter must include a choke reactor in series with the load which separates it from other external loads which will not be filtered (See figures 1 and 2). The choke reactor is not necessary if all the loads downstream of a transformer must be filtered. In this case the transformer leakage reactance does the job. In many cases the choke reactor is placed in a separate cabinet , including also the main switch.

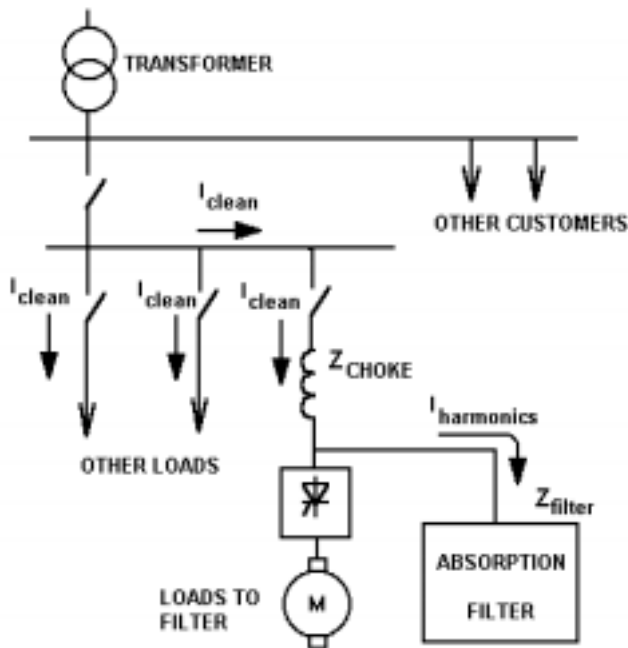

Figure 1.- Absorption filter, separated from the rest of loads by a choke reactor.

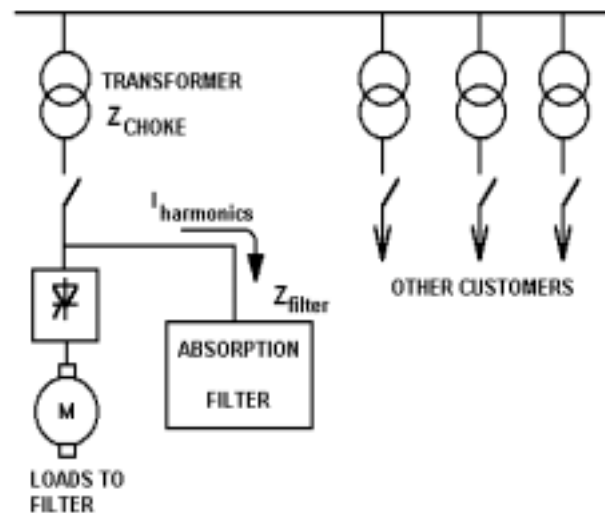

Figure 2.- Absorption filter, separated from the rest of loads by a transformer.

From the constructive point of view , absorption filters are similar to FR rejection filters, but the tuning frequency and the sizing methods are different. Usually, if the current rating is low, the absorption filters can be permanently connected to the network. In case of high current ratings, they can be partially regulated by a current relay (ROYAL) which will connect or disconnect the steps depending on the load level.

2.- TYPES

2.1.- According to the filter configuration

There are several types of absorption filters depending on the following parameters:

- Fundamental frequency of the network to be filtered
- Number of required steps and the detail of tuning frequency for each step.
- Harmonic current to be absorbed by each step.

The following table of types (table 1) shows generic types with a certain number of steps and maximum step current (harmonic current which can be filtered). In the final specification it must be detailed the desired tuning frequency for each step and the type of control (see 2.2)

2.2.- According to the control method.

Depending on the control method we can distinguish two types of absorption filters:

- Manual control types, FA.../M. In these types the steps are manually operated by ON/OFF switches which drive the step power contactors.
- Automatic control types, FA.../A. These types include some manually operated steps, which use to be permanently connected and other steps automatically driven by a current relay (ROYAL type)

The complete range of **standard FA filters** can be seen in the following tables

Table 1. Standard FA filters for 50 Hz networks

CODE	TYPE (*)	SUPPLY V (V)	PASOS	FILTERED CURRENT STEPS x (A)	Q STEPS x (kvar)	CABINET
666 701	FA50-400-3x33	400	3	3 x 33	3 x 17	FA5
666 702	FA50-400-4x33	400	4	4 x 33	4 x 17	FA5
666 703	FA50-400-5x33	400	5	5 x 33	5 x 17	FA5
666 704	FA50-400-10x33	400	7	7 x 33	7 x 17	2 x FA5
666 705	FA50-400-10x33	400	8	8 x 33	8 x 17	2 x FA5
666 706	FA50-400-10x33	400	9	9 x 33	9 x 17	2 x FA5
666 707	FA50-400-10x33	400	10	10 x 33	10 x 17	2 x FA5
666 708	FA50-400-4x80	400	4	4 x 80	4 x 40	FR6
666 709	FA50-400-5x80	400	5	5 x 80	5 x 40	FR6
666 710	FA50-400-6x80	400	6	6 x 80	6 x 40	FR6
666 711	FA50-400-8x80	400	8	8 x 80	8 x 40	2 x FR6
666 712	FA50-400-9x80	400	9	9 x 80	9 x 40	2 x FR6
666 713	FA50-400-10x80	400	10	10 x 80	10 x 40	2 x FR6
666 714	FA50-400-11x80	400	11	11 x 80	11 x 40	2 x FR6
666 715	FA50-400-12x80	400	12	12 x 80	12 x 40	2 x FR6

(*) All the standard types are available in two versions: FA.../M, manually operated and FA.../A which include automatically operated steps

Table 1. Standard FA filters for 60 Hz networks

CODE	TYPE (*)	SUPPLY V (V)	PASOS	FILTERED CURRENT STEPS x (A)	Q STEPS x (kvar)	CABINET
666 721	FA60-400-3x28	400	3	3 x 28	3 x 20	FA5
666 722	FA60-400-4x28	400	4	4 x 28	4 x 20	FA5
666 723	FA60-400-5x28	400	5	5 x 28	5 x 20	FA5
666 724	FA60-400-10x28	400	7	7 x 28	7 x 20	2 x FA5
666 725	FA60-400-10x28	400	8	8 x 28	8 x 20	2 x FA5
666 726	FA60-400-10x28	400	9	9 x 28	9 x 20	2 x FA5
666 727	FA60-400-10x28	400	10	10 x 28	10 x 20	2 x FA5
666 728	FA60-400-4x70	400	4	4 x 70	4 x 50	FR6
666 729	FA60-400-5x70	400	5	5 x 70	5 x 50	FR6
666 730	FA60-400-6x70	400	6	6 x 70	6 x 50	FR6
666 731	FA60-400-8x70	400	8	8 x 70	8 x 50	FR6
666 732	FA60-400-9x70	400	9	9 x 70	9 x 50	FR6
666 733	FA60-400-10x70	400	10	10 x 70	10 x 50	FR6
666 734	FA60-400-11x70	400	11	11 x 70	11 x 50	FR6
666 735	FA60-400-12x70	400	12	12 x 70	12 x 50	2 x FR6

(*) All the standard types are available in two versions: FA.../M , manually operated and FA.../A which include automatically operated steps

3.- TECHNICAL CHARACTERISTICS

The technical characteristics given below apply to all the standard FA filter types. Nevertheless there may be several optional features concerning the control mode, the protection devices or other functional details.

3.1.- General technical characteristics.

Table 3.- Technical characteristics

Standard supply voltages..	400V and 440 V (1)
Frequency	50 Hz or 60 Hz
Ambient temperature	-10 to +45 °C
Main switch	Optional
Protections (each step)	Fuses. Reactor thermostat (disconnection in case of overload)
Filter cabinet:	Epoxy painted metallic sheet
Protections cubicle	IP22
L-C cubicle	Metallic grid : IP21
Standards	IEC-61642 , EN-60439, IEC-664 , EN-60831 , EN-60289
(1) Other supply voltages on request	

Table 3.- Technical Characteristics (Continued)

Cabinets	(See figures 3 and 4)
Control cabinet	Metallic sheet , Epoxy painted , IP 31
L – C cabinet	Metallic grid for better cooling , Epoxy painted, IP 21
Types and weight	(See catalogue)
Dimensions	(see figures 3 and 4)
Type FA5	A single cabinet :L =980 mm , A= 520 mm , H= 2000 mm
Type 2 x FA5	Two cabinets: L =980 mm , A= 520 mm , H= 2000 mm
Type FR6	A single cabinet: L =1100 mm , A= 800 mm , H= 1850 mm
Type 2 x FR6	Two cabinets: L =1100 mm , A= 800 mm , H= 1850 mm

3.2.- Technical characteristics of L-C sets.

Table 4.- Characteristics of L – C filtering groups

Tuning frequency	1,05 f _h
Reactor	
Core / Windings	Oriented grain magnetic sheet / Aluminium band
Isolation voltage	2kV
Tolerance in L value	<3%
Saturation $\Delta L=5\%$	1,6 I _{nominal}
Max. ambient temperature	50°C
Internal temperature at I _{nom}	<110°C
Protection thermal contact	90 °C
Max allowed overload. $\Sigma(n.I_n)^2$	
Permanent	20%
Transient (1 min.)	2 I _{nominal}
Capacitor	
Dielectric	Self-healing polypropylene
Rated voltage	1,15 U _{nominal}
Transient overload (10s)	1000 V
Isolation vs. ground	3 kV
Max. Ambient temperature	Max. 40°C
Losses	0,5W/kvar

3.3.- Dimensions

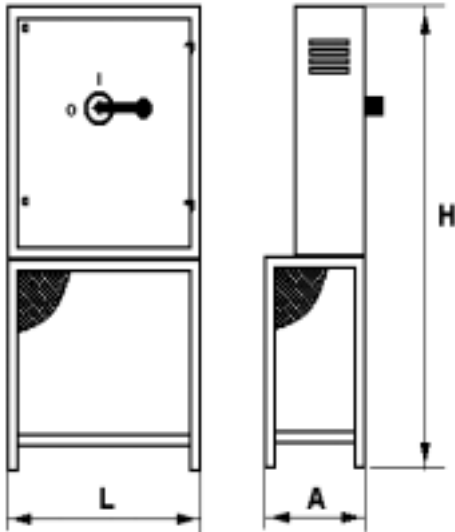

L = 980 mm , A= 520 mm , H= 2000 mm

Fig. 3.- Cabinet for FA5 type filters

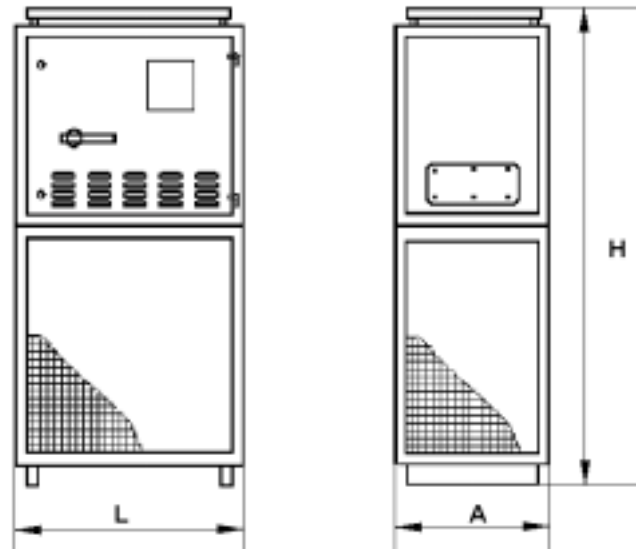

L = 1100 mm , A= 800 mm , H= 1850 mm

Fig. 4.- Cabinet for FR6 type filters

4.- INSTRUCTIONS FOR FA FILTERS INSTALLATION.

4.1.- Initial checking (Before connecting to supply voltage)

To guarantee a good behaviour and prevent against premature ageing of **FA** filters, the following installation rules must be respected.

- Take care of the **cooling** conditions. Allow the necessary space between the cabinet walls and the building walls , so that a good air circulation is guaranteed for cooling.
- **FA** equipment should not be installed close to heat sources. The maximum ambient temperature should not be higher that 40°C. As a particular case, **FA** equipment should not be directly exposed to sun radiation.
- Check the nominal voltage of **FA** equipment, which is indicated in the characteristics plate. It should coincide with the voltage at the site to be connected.
- Check that the configuration (number of steps and rated current of each) are according to the needs of the network where the **FA** has to be installed.

4.2.- Checking the external connections (Before connecting to supply voltage).

All the external connections must be done at the terminals placed at the top of **FA** cabinet.

- Connect the three phase power cables at the power terminals **L1, L2 and L3**. The neutral must be connected to supply the control circuits (contactors). The cable size for power circuit must be according to the FA rated current (see characteristics plate) . Control cables should be 2,5 mm².
- Connect the earth cable to the earth terminal (signed with the corresponding symbol)
- In case of an FA.../A filter, with automatic control by means of ROYAL relay, a **current transformer (CT)** must be placed externally to measure the current at the load. Assuming that the load is reasonably balanced the CT can be placed at any phase. Fig 5 schematically shows the right placement of CT.

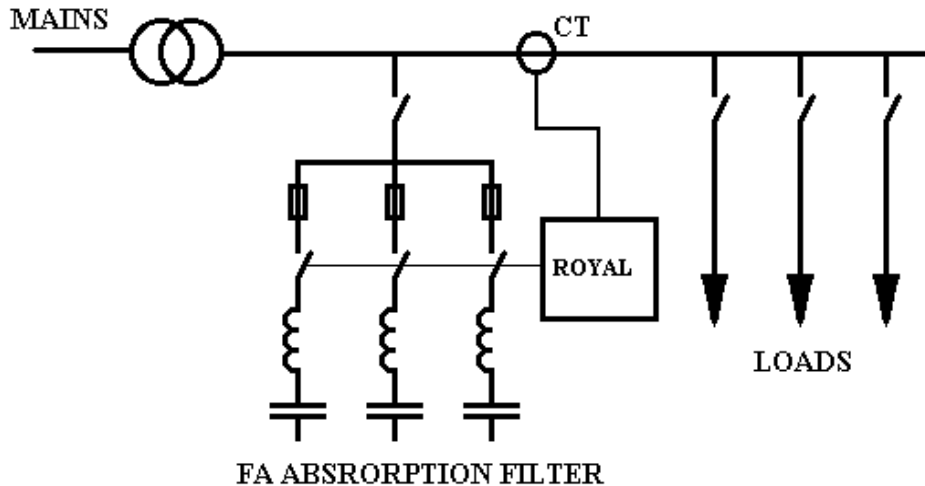

Fig. 5.- CT placement in FA.../A , automatic types

5.- START UP OF FA FILTERS

For the start-up of FA filters, the following steps must be followed:

5.1.- Manual control types FA.../M

- Place all the ON/OFF selector switches in the OFF position and connect the FA equipment to mains.
- Start the equipment step by step, by switching ON the selector switches, starting by the lower step S1 and increasing
- Check that the current consumption of the different steps is within the tolerance limits (use a current clamp giving true RMS value). Notice that in case that there are no harmonics to sink, the current may be below the rated value.

¡ ATENTION!

- Before any manipulation for service purposes, disconnect all the steps by switching all the selector switches OFF from the highest step to the lower. Notice that the disconnection of a step implies the disconnection of all the highest steps.
- Before starting the manipulation for servicing, wait for at least 5 minutes to allow the capacitors to discharge

5.2.- Automatic control types. FA.../A

The usual case is that automatic control FA types have a fixed part of aprox. 1/3 of the total power, controlled by manual switches and two parts, automatically regulated having 1/3 of the power each. The later are controlled by two current relays regulated to switch ON at different load threshold levels (The two relays are usually integrated in a single ROYAL device with two output contacts). Nevertheless, some special equipment may have different configuration. **See the particular configuration sheet of your equipment at the end of this manual.**

- Before starting the first time, place all the ON/OFF selector switches in the OFF position and connect the FA equipment to mains.
- Start the equipment step by step, by switching ON the selector switches, starting by the lower step S1 (fix step) and increasing . When the last switch corresponding to the fix part is switched ON, all the automatic steps may connect at the same time.
- Adjust the ROYAL relay connection levels so that the RA-1 relay connects at 1/3 of the maximum load current and the RA-2 relay connects at 2/3 of the maximum load current. The values adjusted at the factory may be seen in the configuration sheet at the end of this manual. **For details on the ROYAL adjustment procedure, see the ROYAL instructions manual.**
- Check that the current consumption of the different steps is within the tolerance limits (use a current clamp giving true RMS value). Notice that in case that there are no harmonics to sink, the current may be below the rated value.

¡ ATENTION!

- Before any manipulation for service purposes, disconnect all the steps by switching all the selector switches OFF from the highest step to the lower. Notice that the disconnection of a step implies the disconnection of all the highest steps.
- Before starting the manipulation for servicing, wait for at least 5 minutes to allow the capacitors to discharge

6.- TROUBLE SHOOTING.

In case that the FA filter presents an abnormal behaviour when connected to mains, check the following points.

- Check that each manual switch allows the connection of a single step. The test has to be done by switching the steps in ascending order, starting from the 1st. and up. There is an interlock between steps , so that switching OFF a certain step will disconnect all the higher order steps.
- If a step does not switch ON, check the contactor coil or the control relay .
- Check the current of each step. Under normal conditions it must be within the rated values. Use a true RMS current clamp
- In case that some trouble cannot be solved by checking the previous steps, contact the CIRCUTOR technical service department.

¡IMPORTANT!

- Once the permanent conditions have been reached (after 1 hour working) check the temperature at the capacitors and at the reactor core (iron). Capacitors must be below 60°C and iron at the reactors must be below 85°C. In case that higher temperatures are measured, check the cooling of cabinets and external room.

7.- MAINTENANCE

Yearly inspection:

- Check visually if there are some visible defaults in the equipment. Look specially for isolation defaults or burnt components.
- Check the temperature at the capacitors and reactors as in paragraph 6.
- Check the contacts in the power contactors. Replace in case of wear .
- Check that all the steps can be switched OFF and ON again. In case of default check the fuses and the supply voltage.
- Check the current in each step. It must be within the rated limits. In case that the current is higher than nominal, it may be a symptom that the filter power is not enough to sink the ripple current. In this case the filter must be upgraded.
- Check that there are no lose power terminals producing hot contacts.

8.- TECHNICAL SERVICE AND WARRANTY.

All CIRCUTOR products are covered by a warranty of 1 year from the delivery in case of any manufacturing default . The warranty does not cover the protection elements like fuses or other neither the elements subject to ageing in normal service.

This warranty will not be applicable in case of wrong manipulation or in case that the rules of installation have not been respected.

CIRCUTOR offers to all its customers the assistance of its TECHNICAL AND ENGINEERING STAFF

ELECTRICAL

WIRE DIAGRAMS

NOTE: The configuration , number of steps, harmonic to which they are tuned and the way that diferent steps are associated into fix and automatic groups may change in diferent equipment, depending on the project specifications. See configuration sheet.