



**STATIC SWITCHING MODULES
FOR
POWER FACTOR COMPENSATION**

EM. SERIES
(CIRCUTOR Patent Nr. 542258)

INSTRUCTIONS MANUAL
M 981 167/01A

TABLE OF CONTENTS

1	GENERAL DESCRIPTION	2
2	TYPES	2
2.1	Technical characteristics of EM modules:	4
3	EMF and EMB MOUNTING INSTRUCTIONS	5
4	WIRING INSTRUCTIONS FOR EQUIPMENT BASED ON MODULES EM.	6
4.1	Three phase PF compensation equipment.	6
5	BLOCK DESCRIPTION OF EM MODULES.	8
5.1	Static Power Block (BPE)	8
5.2	Zero Switching Control Board (CPCm).	8
6	START UP OF PF COMPENSATORS BASED ON EM MODULES.	9
6.1	Initial checking (before connecting to supply)	9
6.2	Checking immediately after the supply connection	10
7	TROUBLE SHOOTING	10
8	MAINTENANCE.	11
9	TECHNICAL SERVICE AND WARRANTY	11
10	BASIC WIRE DIAGRAM OF AN EM MODULE	12

1 GENERAL DESCRIPTION

The **EM** series of static switching modules are the basic blocks used to build static capacitor banks for power factor (PF) compensation. These static switched capacitor banks use **thyristors** instead of electromechanical switchgears to connect and disconnect the capacitors. The static system is the most convenient in case of large and fast fluctuations of the load current (load changes lasting a few milliseconds to several seconds). The advantages of the static system are the connection at zero voltage and the disconnection at zero current, thus avoiding transients. The ON-OFF switching speed can be as high as 1 operation every 20 ms

Each **EM** module is used to switch ON and OFF a capacitor step. Notice that a fast power factor controller like the **COMPUTER...f** must be used to regulate the power factor using a static switched capacitor bank . The standard PF regulators aren't fast enough to compensate the fast load fluctuations.

2 TYPES

The range of static switching modules consists of four main groups :

- Three phase with fuses , designated as EMF-xx-xxx
- Three phase without fuses , designated as EMB xx-xxx
- Single phase with fuses , designated as EMF xx-xxx M
- Single phase without fuses , designated as EMB xx-xxxM

Note: The symbol "x" means a reference number or character which depends on the type. The final letter "M" means single phase

There are different types depending on the operating voltage and the power of capacitor they are able to operate (see tables 1 to 4)

In the following paragraphs we designate generically as **EM modules** when we refer to general or common characteristics valid for all the types.

TABLE 1.- Three phase EMF modules (Built in fuses)

CODE	OPERATING VOLTAGE	TYPE	POWER (kvar)	LOSSES (W)
4 45 150	380-400V	EMF-40/400	40	115
4 45 151	380-400V	EMF-60/400	60	175
4 45 152	380-400V	EMF-80/400	80	230
4 45 140	220-240 V	EMF-25/230	25	125
4 45 141	220-240 V	EMF-37,5/230	37,5	190
4 45 142	220-240 V	EMF-45/230	45	225

TABLE 2.- Three phase EMB modules
(External fuses must be included)

CODE	OPERATING VOLTAGE	TYPE	POWER (kvar)	EXTERNAL FUSES	TYPE
4 45 156	380-400V	EMB-40/400	40	80 A	gl
4 45 157	380-400V	EMB-60/400	60	125 A	gl
4 45 158	380-400V	EMB-80/400	80	160 A	gl
4 45 146	220-240 V	EMB-25/230	25	80 A	gl
4 45 147	220-240 V	EMB-37,5/230	37,5	125 A	gl
4 45 148	220-240 V	EMB-45/230	45	160 A	gl

Note: Losses are approx. the same as modules EMF of equal size.

TABLE 3.- Single phase EMF modules (Built in fuses)

CODE	OPERATING VOLTAGE	TYPE	POWER (kvar)	LOSSES (W)
4 45 180	380-400V	EMF-15/400-M	15	45
4 45 181	380-400V	EMF-30/400-M	30	90
4 45 182	380-400V	EMF-60/400-M	60	180
4 45 170	220-240 V	EMF-7,5/230-M	7,5	45
4 45 171	220-240 V	EMF-15/230-M	15	90
4 45 172	220-240 V	EMF-30/230-M	30	180

TABLE 4.- Single phase EMB modules (External fuses must be included)

CODE	OPERATING VOLTAGE	TYPE	POWER (kvar)	EXTERNAL FUSES	TYPE
4 45 186	380-400V	EMB-15/400-M	15	50 A	gl
4 45 187	380-400V	EMB-30/400-M	30	100 A	gl
4 45 188	380-400V	EMB-60/400-M	60	200 A	gl
4 45 176	220-240 V	EMB-7,5/230-M	7,5	50 A	gl
4 45 177	220-240 V	EMB-15/230-M	15	100 A	gl
4 45 178	220-240 V	EMB-30/230-M	30	200 A	gl

Note: Losses are approx. the same as modules EMF of equal size.

2.1 Technical characteristics of EM modules:

Standard supply voltage (power block)	400 Vac / 230 Vac (other values up to 690 Vac , on request)
Frequency	50 / 60 Hz (either)
Rated power of C step	see table of types
Overload capability.	1,5 Inom during 1 minute
Protections	
Fuses	NH type (size according to rated current)
dV/dt	RC protection at 1000 V/μs
Thermostat	90 °C (Opens ENABLE circuit A-C)
di/dt	100 A/μs (L= 12μH , not included , must be mounted in series with the Capacitor)
Max. ambient temperature	40 °C
Max. heatsink temperature	80 °C
Protection degree	IP00
Dimensions	See figure 1
Mounting distances	
Weight	10,5 kg.
Control of the static switch:	
Auxiliary supply at terminals B1-B2	400 Vac / 230 Vac (Shown in the label)
Control method	Potential free contact between terminals A and C
V _{A-C} open circuit	(see table 5)
I _{A-C} closed circuit	18 V cc < 1mA

Table 5.- ON-OFF operation method

Terminals A - C	Green LED	STATIC SWITCH STATUS
OPEN CIRCUIT	OFF	DISCONNECTED
CLOSED CIRCUIT	ON	CONNECTED

Standards: EN 60.439 (IEC 439 , UNE 20 098) , IEC 146 , CSA 22.2 N°14

Accessories: COMPUTER...f , TP series current transformers , 6 terminals capacitors

Note: On request, CIRCUTOR may supply special static modules for operation up to 550 V_{RMS}. The CPC board and the power block are specially sized for high voltage in case of line voltages exceeding 440 V

3 EMF AND EMB MOUNTING INSTRUCTIONS

To get optimal working conditions of the static switching modules, the following recommendations must be followed:

The modules should be installed inside a closed cabinet taking care of the fixing and **cooling** conditions. To ensure the proper cooling conditions, certain minimum clearances must be left free between the EM modules and other elements into the cabinet , as shown in the figure 1

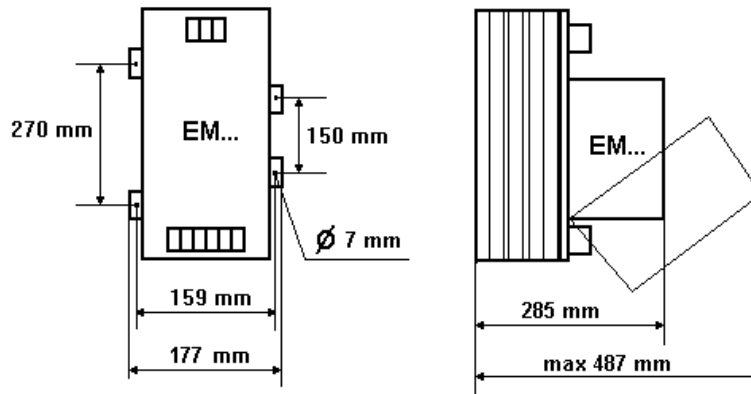

a) Dimensions

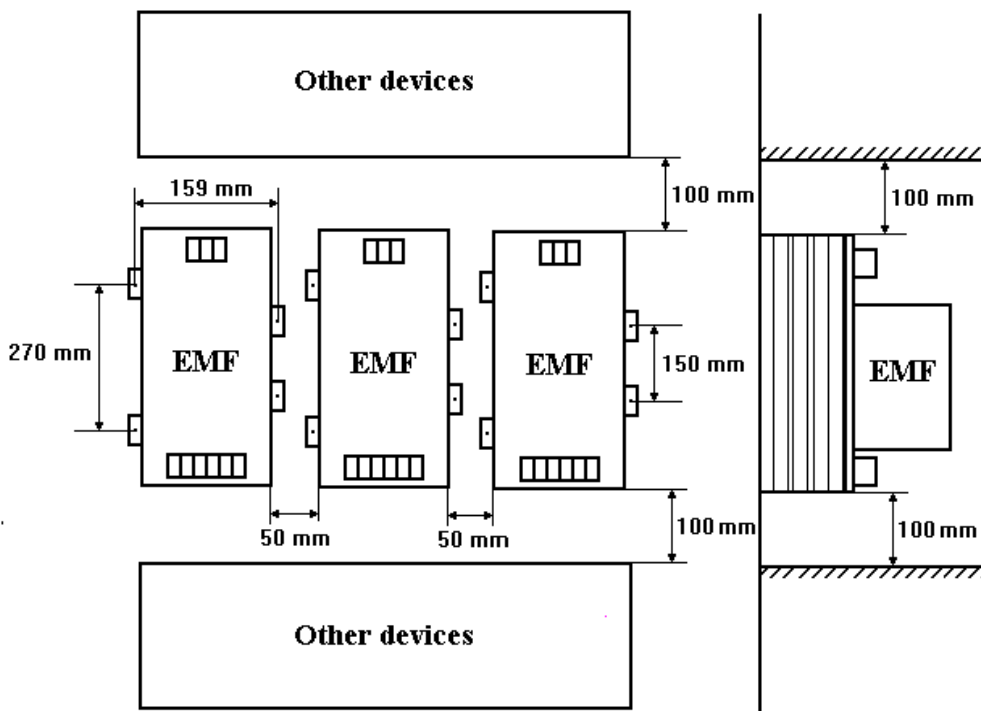

b) Minimum clearances for cooling

Figure 1.- Dimensions and mounting distances

- As a thumb rule, the cabinet cooling system should provide approximately an air flow of $6 \text{ m}^3/\text{h}$ for each kW of total losses (including all the elements into the cabinet, fuses, lamps, switchgears, coils, etc.)
- The EM modules must be placed in the upright position with the heatsink channels oriented in the vertical sense. The top and bottom parts of the heatsink must be kept free for air circulation
- Avoid mounting the EM modules close to hot components or devices emitting heat. The maximum ambient temperature inside the cabinet should be kept below $45 \text{ }^\circ\text{C}$.

4 WIRING INSTRUCTIONS FOR EQUIPMENT BASED ON MODULES EM.

When building static power factor compensation equipment, based on the EM modules, the following wiring instructions must be followed.

4.1 Three phase PF compensation equipment.

- For this application the three phase EMF or EMB modules must be used together with three single phase capacitors or a three phase capacitor with 6 terminals (internally built as three single phase caps.). The connection of each EM module to the corresponding step of capacitors must be as shown in figure 2.

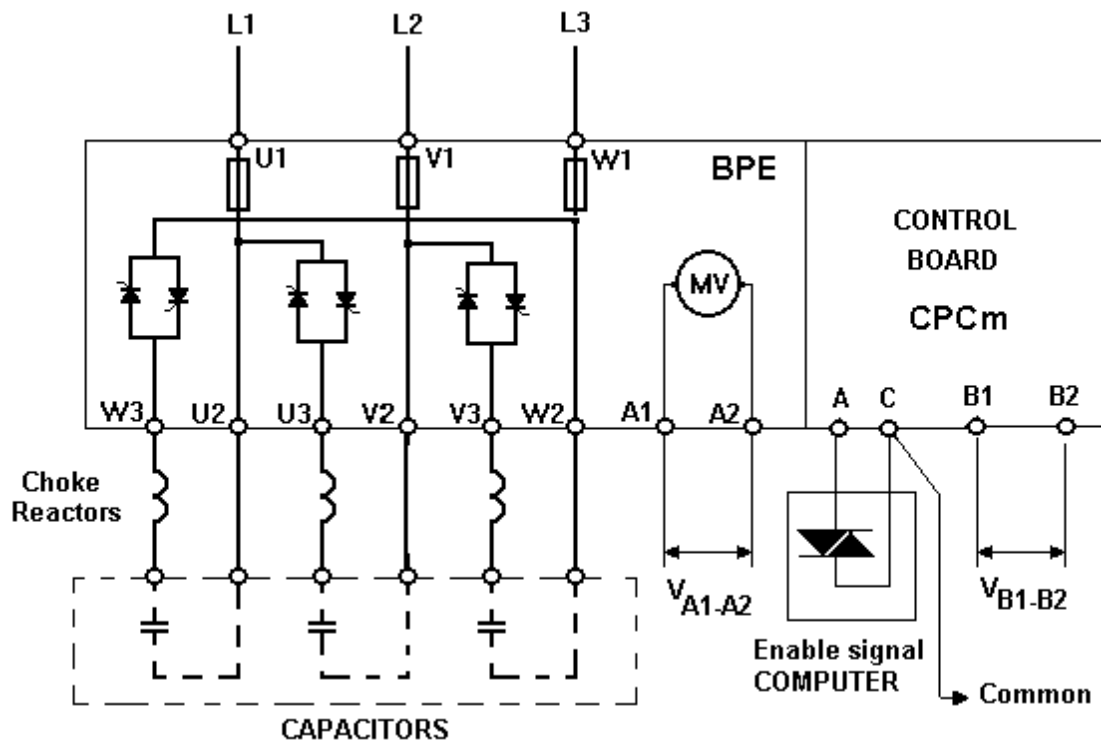

Figure 2.- Basic wire diagram for a three phase EM module.

- Three phase EMF or EMB modules consist of three circuit branches, each having a power pack with two anti-parallel thyristors. Each module is provided with three input terminals and six output terminals.
- Three phase EMB modules must be protected with three external fuses in series with L1, L2 and L3 line cables. The fuses type must be in accordance with the EM size and is given in table 2. EMF modules have built in fuses.

4.2.- Single phase PF compensation equipment.

Some single phase loads, such as soldering machines and others need a fast PF compensation. For such PF compensation equipment, single phase EM modules may be used, taking care of the following points:

- For single phase applications a special type of PF regulator (COMPUTER...f- Single phase) must be used. Sometimes a simple current relay or even a potential free contact coming from the load controller can be used (See paragraph 5.2).
- Single phase EM modules are similar to three phase ones. The main difference is that they have a unique power pack with two anti-parallel thyristors (see fig. 3)

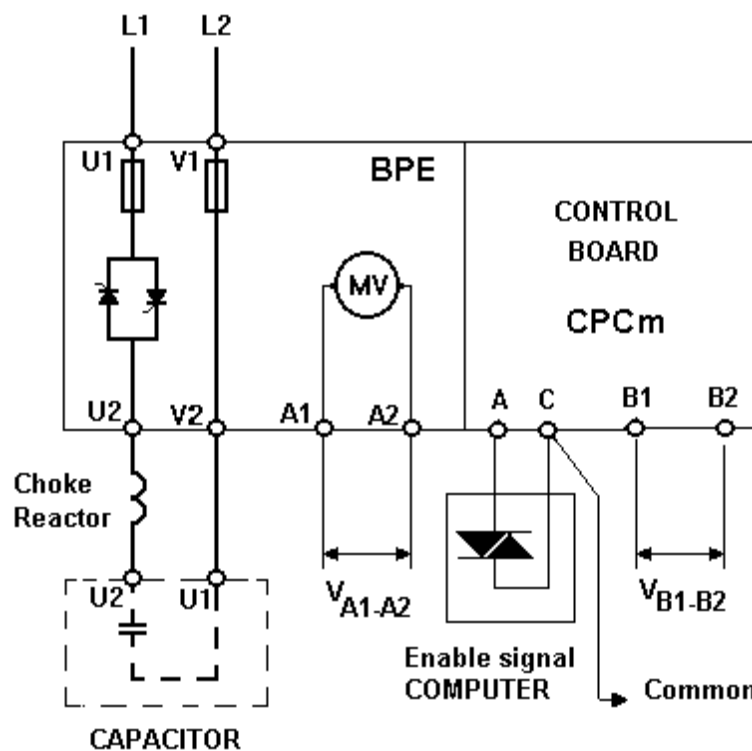

Figure 3.- Basic wire diagram for single phase EM modules.

- Single phase modules, EMB...-M, must be protected with two external fuses in series with L1, and L2 line cables. The type and size of the fuses must be in accordance with the EM size (see table 4)

5 BLOCK DESCRIPTION OF EM MODULES.

All the EM modules consist of two basic blocks: (See figures 2 and 3).

5.1 Static Power Block (BPE)

This block basically consists of two thyristors for each phase , the fuses (only in EMF... modules) , the heatsink , the fan and the protection thermostat. The size of the power components depends on the $Q(kvar)$ of the capacitor which has to be switched

5.2 Zero Switching Control Board (CPCm).

The CPCm control board receives the enable signal for ON-OFF operation of the static switch. This enable signal is usually given by a PF regulator (usually a COMPUTER...f) and is connected to terminals A and C. The static switch operation according to this signal, is resumed in table 5 in the technical characteristics.

The CPCm has a green LED , showing the status of the enable signal and three red LEDs , one for each phase , showing whether the phase is ON or OFF. The card has also a set of 12 terminals connected to the thyristors through optocouplers, to obtain the synchronism for switching at zero voltage. The CPC must be supplied from an auxiliary source from terminals B1 and B2 (See module label for nominal value). The ENABLE terminals, ACT-COM, are connected to external terminals A and C.

Notice that all the synchronism between the CPCm card and the thyristor blocks are coupled through optoisolated devices and the firing signals are coupled through pulse transformers, therefore , the electronic circuits and the power block are galvanically isolated.

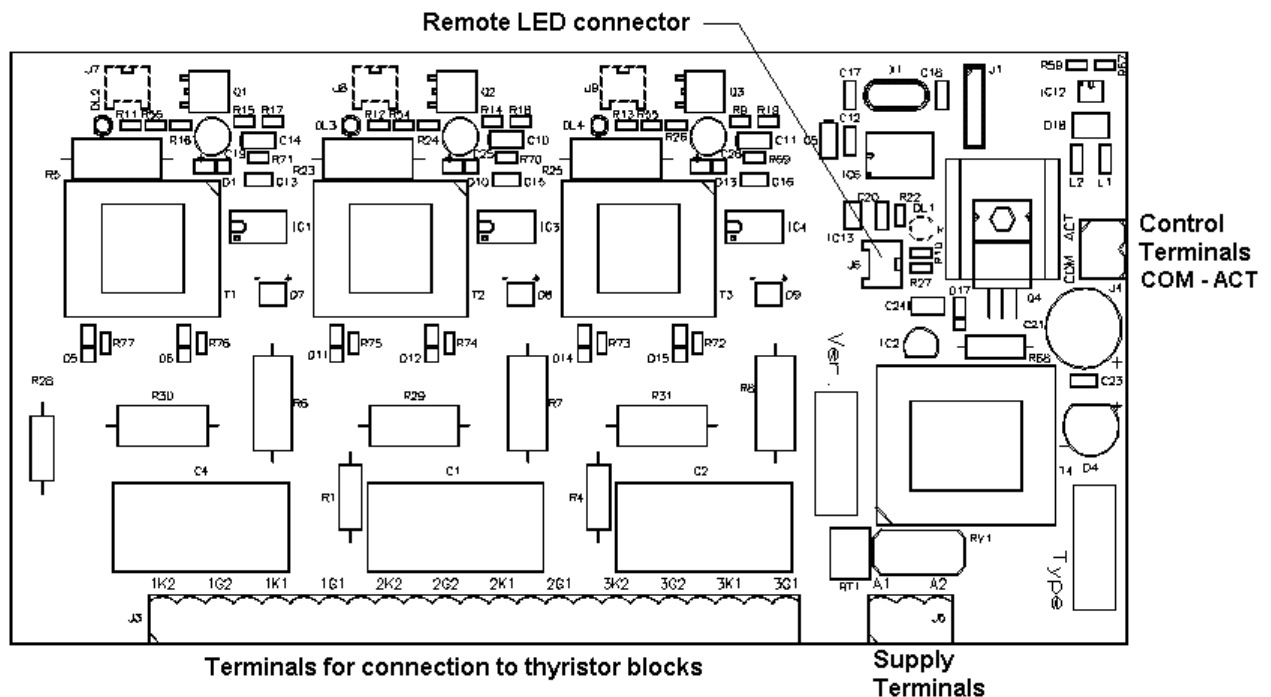

Figure 4 .- Layout of CPCm printed circuit board

6 START UP OF PF COMPENSATORS BASED ON EM MODULES.

To start up static PF compensation equipment, based on the EM modules, follow the steps below.

6.1 Initial checking (before connecting to supply)

- Check that the rated voltage for the EM modules, shown in the characteristics label, conforms with the rated voltage available in the site where the equipment has to be installed
- Check that the EM modules are supplied through the auxiliary supply terminals B1-B2 with the rated voltage value shown in the label.
- Check that the power of EM modules is in accordance with the size of the capacitors which have to operate.
- Check that the connections between the EM modules and the capacitors correspond to one of the figures 2 or 3 (three phase or single phase).
- The external connections of a static capacitor bank are identical to those of a standard capacitor bank using electromechanical switchgears. The section 10 shows a diagram illustrating the internal and external wiring of a single EM module, including the connections between the CPCm board and the thyristor blocks.
- Check the connections between the EM modules, the PF regulator (COMPUTER...f) and the current transformer (CT). For details concerning the regulator adjustment see the instructions manual of COMPUTER...f. See also the figure 5 showing the right location of CT in the installation.

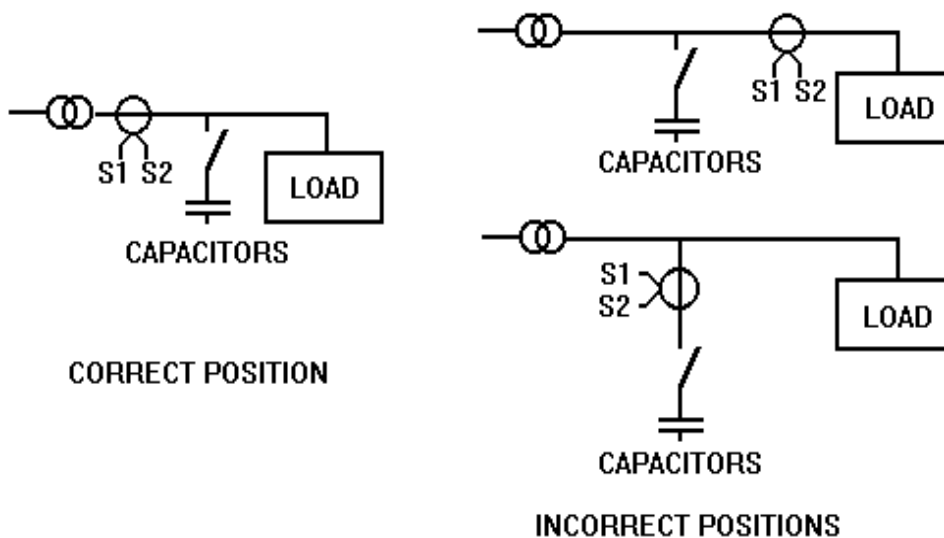

Figure 5.- Location of the current transformer (CT)

6.2 Checking immediately after the supply connection

; ATTENTION! Before any attempt of manipulation on the PF correction equipment wait 5 minutes for capacitors discharge after the supply has been removed.

In static capacitor banks, where the load has great fluctuations, it must be considered normal that the switches operate very often. Nevertheless if the PF regulator operates the capacitor steps very quickly when the load remains constant, check the COMPUTER...f adjustments.

7 TROUBLE SHOOTING

The capacitor bank should operate only if there is a minimum load. If the equipment does not work properly check the following points:

- If the display of the COMPUTER...f does not light or gives a very slight bright , check the supply voltage and the fuses (power and control fuses)
- If the display of the COMPUTER...f shows an error, see the COMPUTER... instructions manual. Check also the CT connections
- If the LED pointing to the letter C is lighting , means that the COMPUTER...f sees a capacitive load. If an inductive load is expected, then check the CT phase settings and the CT connections.
- During the normal operation , the number of connected steps can be seen by the indication LED in the front panel of COMPUTER...f. Check that the number of connected steps conforms with the Nr. of steps shown by the COMPUTER..f LEDs.
- To see whether a step is connected or not, see the green LED at the CPCm card. The green LED and the three red LEDs must light simultaneously , otherwise indicates that there is one of the phases which does not work properly.
- If one of the steps is never connected, try to force its connection by jumping the terminals A and C in the corresponding EM module. If the step connects in the forced mode (check the current in each phase with a current clamp) , then the fault is probably in the COMPUTER...f or in the wiring.
- If there are some inactive steps and the COMPUTER...f shows a lack of compensation , check the settings of such COMPUTER...f.
- Once the normal operation is achieved , check if the current consumption of each step is correct, according to its rated power (Current is shown in the capacitor label). An excess of consumption may be due to an excess of supply voltage or to the presence of harmonics.
- In case of a faulty operation which may not be solved with the above indications , contact the CIRCUTOR S.A. technical service.

;IMPORTANT!

After one hour in normal operation , check the temperature of the heat sinks. It must be below 80 °C. In case of higher temperature check the cooling conditions.

8 MAINTENANCE.

Yearly inspection:

- Inspect the equipment visually and check the temperature of the capacitors and the thyristor heat sinks.
- Check that all the steps operate when necessary. Otherwise check the fuses.
- Check that the supply voltage is within the limits.
- Check that the current of each step is in accordance with its labelled value. A higher current may be due to the presence of harmonics. A low current may indicate a faulty capacitor.
- Check that there are not loose connections at the terminals.

9 TECHNICAL SERVICE AND WARRANTY

All CIRCUTOR products are covered by a warranty of 1 year in case of any manufacturing default . The warranty does not cover the protection elements like fuses or other, neither the elements subject to ageing in normal service.

This warranty will not be applicable in case of wrong manipulation or in case that the rules of installation have not been respected.

CIRCUTOR offers to all its customers the assistance of its TECHNICAL AND ENGINEERING DEPARTMENTS.

10 BASIC WIRE DIAGRAM OF AN EM MODULE

