

R.3

Power factor correction and harmonic filtering



Automatic capacitor banks

R.3

Automatic capacitor banks

Introduction	3
R.3 - Automatic capacitor banks	
Selection table	4
AM	
CLZ Capacitor with circuit breaker	5
ACM	
CLZ Capacitor with contactor and circuit breaker	7
ACD	
CLZ Capacitor with contactor, circuit breaker and power factor relay	9
ACF	
CS Capacitor with contactor and fuses	11
STANDARD (STD)	
Automatic capacitor banks	13
PLUS	
Automatic capacitor banks	16

Automatic capacitor banks

CIRCUTOR's range of capacitor banks for contactor switching operations cover power levels 7.5 kvar to 1120 kvar (in the case of greater power levels, please ask).

Initial data:

Data that must be taken into account when selecting a capacitor bank:

- Total power factor consumption of the installation and $\cos \varphi$ objective.
- Voltage: the voltage of the unit must always be equal to or higher than the network voltage.
- Harmonic distortion levels
- Simultaneity of loads.
- Regulation of the capacitor bank: we recommend an approximate power of 10% of the total power of the unit in the first step.

Technical instruction ITC-BT-43 of the REBT, section 2.7 (Power factor correction) must be taken into account when selecting a capacitor bank:

The installations that supply energy to receivers with a power factor under 1 can be compensated. However, the energy absorbed by the network can not be capacitive.

The Power factor correction process can be carried out as follows:

- ▶ *For each receiver or group of receivers operating at the same time and which are connected with a single switch. In this case the switch must cut off the power supply of the receiver or group of receivers and capacitor at the same time.*
- ▶ *For the whole installation. In this case, the compensation installation must be designed to make sure that the variation of the power factor does not automatically exceed $\pm 10\%$ of the mean values obtained during a long period of operation.*

As a consequence, the installation can be compensated automatically at the header or individually.

Automatic compensation at the header

When selecting an automatic capacitor bank, it is important to distinguish between the number of electrical steps and the number of physical steps.

The number of physical steps is described by the number of contactor + capacitor groups. In turn, electrical steps are defined by the different electrical



combinations of the unit. The number of electrical steps is the result of dividing the total power of the unit by the power of the lowest step. Here is an example.

Example:

440 kvar Capacitor bank
Composition: (40 + 5x80) This capacitor bank has 6 physical steps: One 40 kvar step and five 80 kvar steps, and 11 electrical steps: 11 x 40 kvar.

From the point of view of efficiency, it is very important that the capacitor bank has enough electrical steps that can adapt to the demands of $\cos \varphi$.

A good balance between the physical and electrical regulation will allow us to fine tune the system at the lowest price.



Product selection table

	Equipment	Compensation	Scope	Page
AM		Fixed (Capacitor + Circuit Breaker)	2 to 30 kvar (440 V)	5
ACM		Fixed (Capacitor + Contactor + Circuit Breaker)	2 to 30 kvar (440 V)	7
ACD		Fixed (Capacitor + Contactor + Circuit Breaker + Power factor relay)	2 to 30 kvar (440 V)	9
ACF		Fixed (Capacitor + Contactor + Fuse protection)	20 to 40 kvar (230 V) 30 to 100 kvar (440 V)	11
STANDARD (STD)		Automatic (Single-phase measurement)	Up to 35 kvar: STD3 Up to 100 kvar: STD4 Up to 180 kvar: STD6 Up to 360 kvar: STD12 Up to 480 kvar: STD8 Up to 800 kvar: STD SC8 Up to 1600 kvar: STD SC16	13
PLUS		Automatic (Three-phase measurement)	Up to 100 kvar: PLUS4 Up to 180 kvar: PLUS6 Up to 360 kvar: PLUS12 Up to 480 kvar: PLUS8 Up to 800 kvar: PLUS SC8 Up to 1600 kvar: PLUS SC16	16

AM

CLZ Capacitor with circuit breaker



Description

The fixed capacitors of the **AM** series are single-step units that have been designed for Power factor correction procedures under constant load.

Application

Its application is mainly focused on the compensation of motors, transformers and installations where the load levels are constant.

Features

Features		
Operating voltage		230, 400 V (for other voltages, please ask)
Support voltage (400 V)		440 V
Capacity tolerance		± 10%
Unit composed of		<ul style="list-style-type: none"> • CLZ capacitor • Header protection with circuit breaker
Insulation level		3 / 15 kV
Discharge resistance		75 V / 3 minutes
Overload		1.3 times the rated current permanently
Overvoltage		<ul style="list-style-type: none"> • 10% 8 over 24 hours • 15% up to 15 minutes over 24 hours • 20% up to 5 minutes over 24 hours • 30% up to 1 minutes over 24 hours
Contactor operating voltage		230 V
Ambient conditions		
Class D temperature	Daily mean	45 °C
	Annual mean	35 °C
	Maximum	50 °C
	Minimum	-25 °C
Humidity		80% RH
Altitude		2,000 m
Construction features		
Degree of protection		IP 21
Colour		RAL 7035 Grey RAL 3005 Maroon
Assembly conditions		
Type of assembly		Vertical
Ventilation		Natural
Standards		
CEI 60831-1, CEI 70/7, UNE 20827, UNE 20010, BS 1650, VDE 560		

AM

CLZ Capacitor with circuit breaker

Dimensions

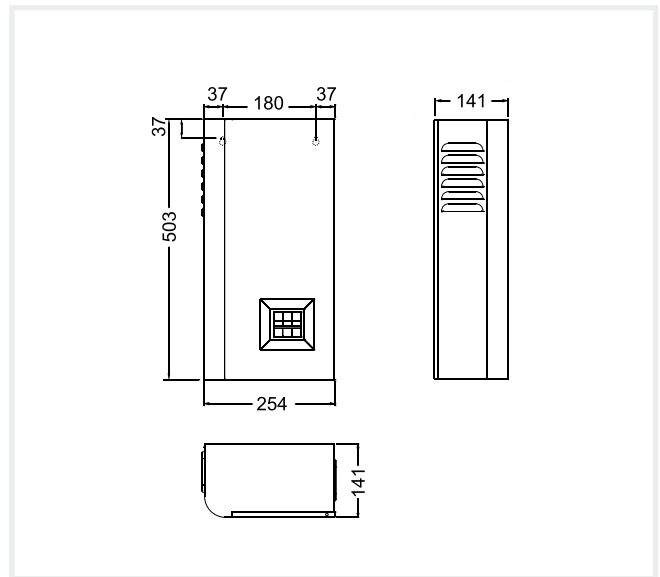

References

kvar		Cut off power (kA)	(A)	Cable section (mm ²)	Weight (kg)	Dimensions (mm) width x height x depth	Type	Code
440 V	400 V							
2,5	2	10	3,3	6	8	254 x 503 x 141	AM-2,5-440	R3N321
5	4	10	6,6	6	9	254 x 503 x 141	AM-5-440	R3N351
6,25	5	10	8,2	6	9,3	254 x 503 x 141	AM-6.25-440	R3N3C1
7,5	6	10	10	6	9,5	254 x 503 x 141	AM-7.5-440	R3N361
10	8	10	13	6	10	254 x 503 x 141	AM-10-440	R3N371
12,5	10	10	16	6	10	254 x 503 x 141	AM-12.5-440	R3N381
15	12,5	10	20	6	10	254 x 503 x 141	AM-15-440	R3N391
20	17	10	26	10	11	254 x 503 x 141	AM-20-440	R3N3A1
25	21	10	33	10	12	254 x 503 x 141	AM-25-440	R3N3B1
30	25	16	39	10	12,5	254 x 503 x 141	AM-30-440	R3N3D1

ACM

CLZ Capacitor with contactor and circuit breaker



Description

The fixed capacitors of the **ACM** series are single-step units that have been designed for Power factor correction procedures in individual scenarios or under constant load.

Application

Its application is mainly focused on the compensation of motors, transformers and installations under constant load, providing a signal that connects to the capacitor with a contactor switching operation.

Features

Features		
Operating voltage		230, 400 V (for other voltages, please ask)
Support voltage (400 V)		440 V
Capacity tolerance		± 10%
Unit composed of		<ul style="list-style-type: none"> • CLZ capacitor • Contactors with pre-insertion block and quick discharge resistor • Header protection with circuit breaker
Insulation level		3 / 15 kV
Discharge resistance		75 V / 3 minutes
Overload		1.3 times the rated current permanently
Overvoltage		<ul style="list-style-type: none"> • 10% 8 over 24 hours • 15% up to 15 minutes over 24 hours • 20% up to 5 minutes over 24 hours • 30% up to 1 minutes over 24 hours
Contactor operating voltage		230 V
Ambient conditions		
Class D temperature	Daily mean	45 °C
	Annual mean	35 °C
	Maximum	50 °C
	Minimum	-25 °C
Humidity		80% RH
Altitude		2,000 m
Construction features		
Degree of protection		IP 21
Colour		RAL 7035 Grey RAL 3005 Maroon
Assembly conditions		
Type of assembly		Vertical
Ventilation		Natural
Standards		
CEI 60831-1, CEI 70/7, UNE 20827, UNE 20010, BS 1650, VDE 560		

ACM

CLZ Capacitor with contactor
and circuit breaker

Dimensions

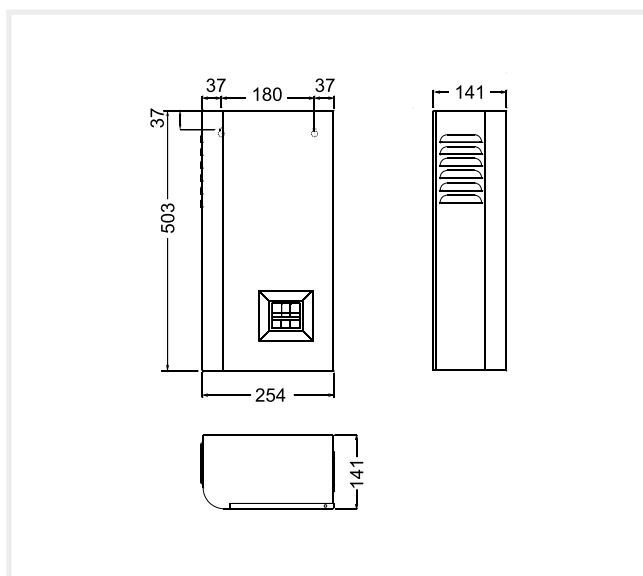

References

kvar		Cut off power (kA)	(A)	Cable section (mm ²)	Weight (kg)	Dimensions (mm) width x height x depth	Type	Code
440 V	400 V							
2,5	2	10	3,3	6	8	254 x 503 x 141	ACM-2.5-440	R3P521
5	4	10	6,6	6	9	254 x 503 x 141	ACM-5-440	R3P551
6,25	5	10	8,2	6	9	254 x 503 x 141	ACM-6.25-440	R3P5C1
7,5	6	10	10	6	10	254 x 503 x 141	ACM-7.5-440	R3P561
10	8	10	13	6	10	254 x 503 x 141	ACM-10-440	R3P571
12,5	10	10	16	6	10	254 x 503 x 141	ACM-12.5-440	R3P581
15	12,5	10	20	6	11	254 x 503 x 141	ACM-15-440	R3P591
20	17	10	26	10	11	254 x 503 x 141	ACM-20-440	R3P5A1
25	21	10	33	10	12	254 x 503 x 141	ACM-25-440	R3P5B1
30	25	16	39	10	12,5	254 x 503 x 141	ACM-30-440	R3P5D1

ACD

CLZ Capacitor with contactor,
circuit breaker and power factor relay



Description

The fixed capacitors of the **ACD** series are single-step units that have been designed for Power factor correction procedures in individual scenarios or under constant load.

Application

Its application is mainly based on the compensation of motors, transformers and installations under constant load, with a power factor relay (**DIR**) that sends the capacitor activation signal when the $\cos \varphi$ is under the threshold established by **DIR**.

Features

Features		
Operating voltage		230, 400 V (for other voltages, please ask)
Support voltage (400 V)		440 V
Capacity tolerance		± 10%
Unit composed of		<ul style="list-style-type: none"> • CLZ capacitor • Contactors with pre-insertion block and quick discharge resistor • Power factor relay (DIR)
Insulation level		3 / 15 kV
Discharge resistance		75 V / 3 minutes
Overload		1.3 times the rated current permanently
Overvoltage		<ul style="list-style-type: none"> • 10% 8 over 24 hours • 15% up to 15 minutes over 24 hours • 20% up to 5 minutes over 24 hours • 30% up to 1 minutes over 24 hours
Contactor operating voltage		230 V
Ambient conditions		
Class D temperature	Daily mean	45 °C
	Annual mean	35 °C
	Maximum	50 °C
	Minimum	-25 °C
Humidity		80% RH
Altitude		2,000 m
Construction features		
Degree of protection		IP 21
Colour		RAL 7035 Grey RAL 3005 Maroon
Assembly conditions		
Type of assembly		Vertical
Ventilation		Natural
Standards		
CEI 60831-1, CEI 70/7, UNE 20827, UNE 20010, BS 1650, VDE 560		

ACD

CLZ Capacitor with contactor,
circuit breaker and power factor relay



Dimensions

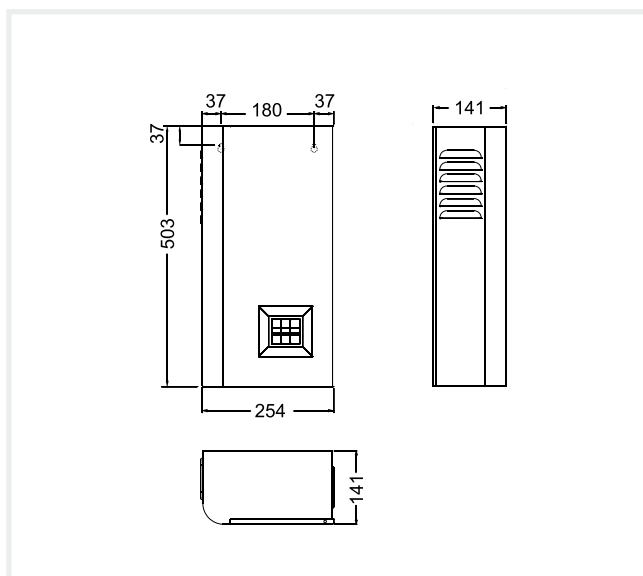

References

kvar		Cut off power (kA)	(A)	Cable section (mm ²)	Weight (kg)	Dimensions (mm) width x height x depth	Type	Code
440 V	400 V							
2,5	2	10	3,3	6	8,5	254 x 503 x 141	ACD-2.5-440	R3Q321
5	4	10	6,6	6	9,5	254 x 503 x 141	ACD-5-440	R3Q351
6,25	5	10	8,2	6	9,5	254 x 503 x 141	ACD-6.25-440	R3Q3C1
7,5	6	10	10	6	9,5	254 x 503 x 141	ACD-7.5-440	R3Q361
10	8	10	13	6	10,5	254 x 503 x 141	ACD-10-440	R3Q371
12,5	10	10	16	6	10,5	254 x 503 x 141	ACD-12.5-440	R3Q381
15	12,5	10	20	6	10,5	254 x 503 x 141	ACD-15-440	R3Q391
20	17	10	26	10	11,5	254 x 503 x 141	ACD-20-440	R3Q3A1
25	21	10	33	10	12,5	254 x 503 x 141	ACD-25-440	R3Q3B1
30	25	16	39	10	13	254 x 503 x 141	ACD-30-440	R3Q3D1

ACF

CS Capacitor with contactor and fuses



Description

The fixed capacitors of the **ACF** series are single-step units that have been designed for Power factor correction procedures under constant load.

Application

Its application is mainly focused on the compensation of motors, transformers and installations under constant load, providing a signal that connects to the capacitor with a contactor switching operation.

Features

Features		
Operating voltage		230, 400 V (for other voltages, please ask)
Support voltage (400 V)		440 V
Capacity tolerance		± 10%
Unit composed of		<ul style="list-style-type: none"> • CS capacitor • Contactors with pre-insertion block and quick discharge resistor • Header protection with high rupture power (HRP)
Insulation level		3 / 15 kV
Discharge resistance		75 V / 3 minutes
Overload		1.3 times the rated current permanently
Overvoltage		<ul style="list-style-type: none"> • 10% 8 over 24 hours • 15% up to 15 minutes over 24 hours • 20% up to 5 minutes over 24 hours • 30% up to 1 minutes over 24 hours
Contactor operating voltage		230 V
Ambient conditions		
Class D temperature	Daily mean	45 °C
	Annual mean	35 °C
	Maximum	50 °C
	Minimum	-25 °C
Humidity		80% RH
Altitude		2,000 m
Construction features		
Degree of protection		IP 21
Colour		RAL 7035 Grey RAL 3005 Maroon
Assembly conditions		
Type of assembly		Vertical
Ventilation		Natural
Standards		
CEI 60831-1, CEI 70/7, UNE 20827, UNE 20010, BS 1650, VDE 560		

ACF

CS Capacitor with contactor and fuses

Dimensions

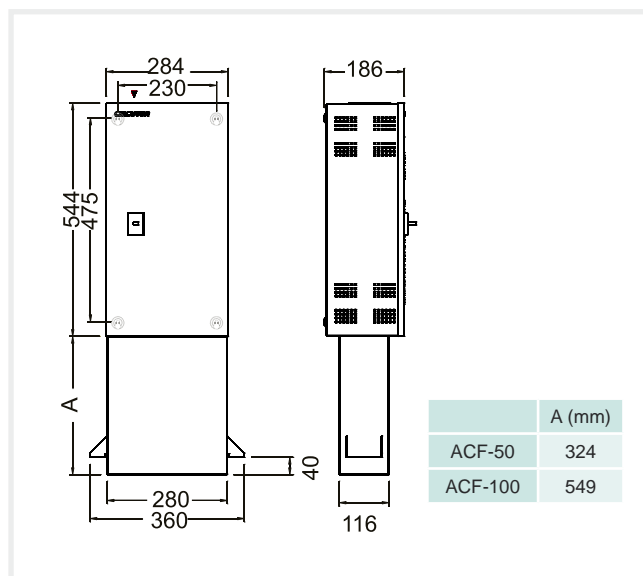

References

230 V

kvar	Cut off power	(A)	Fuses	Cable section (mm ²)	Weight (kg)	Dimensions (mm) width x height x depth	Type	Code
20	120 kA	50	125	25	17	360 x 868 x 140	ACF-20-230	R3S141
25	120 kA	63	125	35	21	360 x 1093 x 140	ACF-25-230	R3S151
30	120 kA	75	160	50	22	360 x 1093 x 140	ACF-30-230	R3S161
40	120 kA	100	160	70	27	360 x 1093 x 140	ACF-40-230	R3S181

440 V

kvar	Cut off power	(A)	Fuses	Cable section (mm ²)	Weight (kg)	Dimensions (mm) width x height x depth	Type	Code	
12,5	10	120 kA	16	35	6	12	360 x 868 x 140	ACF-12.5-440	R3S421
15	12,5	120 kA	20	35	10	13	360 x 868 x 140	ACF-15-440	R3S431
20	17	120 kA	26	50	10	14	360 x 868 x 140	ACF-20-440	R3S441
25	21	120 kA	33	63	10	15	360 x 868 x 140	ACF-25-440	R3S451
30	25	120 kA	39	80	16	16	360 x 868 x 140	ACF-30-440	R3S461
37,5	31	120 kA	49	80	25	17	360 x 868 x 140	ACF-37.5-440	R3S481
50	42	120 kA	66	125	35	21	360 x 868 x 140	ACF-50-440	R3S491
60	50	120 kA	79	160	50	22	360 x 1093 x 140	ACF-60-440	R3S4A1
75	63	120 kA	99	160	70	24	360 x 1093 x 140	ACF-75-440	R3S4B1
100	80	120 kA	131	160	70	29	360 x 1093 x 140	ACF-100-440	R3S4D1

STANDARD (STD)

Automatic capacitor banks



Description

The capacitor banks of the **STD** series have been designed for power compensation purposes in networks with fluctuating loads and power variations during seconds, so that the switching operations can be carried out by contactors.

Application

Its simple installation, state-of-the-art technology and robustness make the **STD** series units the ideal equipment to compensate installations with fluctuating load levels.

Features

Features		
Operating voltage		230, 400 V (for other voltages, please ask)
Support voltage (400 V)		440 V
Capacity tolerance		0, ± 10%
Unit composed of		<ul style="list-style-type: none"> • CLZ capacitor (except STD3 and STD4) • Contactors with pre-insertion block and quick discharge resistor • Header protection with high rupture power (HRP). NH-00 Series • Power factor regulator of the computer m series, with digital display and 6 or 12 relay outputs, depending on the type
Add-ons		<ul style="list-style-type: none"> • Manual capacitor bank header switch • Automatic capacitor bank header switch • Automatic switch + Earth leakage protection at the capacitor bank's header • Forced ventilation unit + thermostat • Polycarbonate plate to protect against direct contacts • Auto-transformer 400/230 V
Insulation level		3 / 15 kV
Discharge resistance		75 V / 3 minutes
Overload		1.3 times the rated current permanently
Overvoltage		<ul style="list-style-type: none"> • 10% 8 over 24 hours • 15% up to 15 minutes over 24 hours • 20% up to 5 minutes over 24 hours • 30% up to 1 minutes over 24 hours
Contactor operating voltage		230 V
Ambient conditions		
Class D temperature	Daily mean	45 °C
	Annual mean	35 °C
	Maximum	50 °C
	Minimum	-25 °C
Humidity		80% RH
Altitude		2,000 m
Construction features		
Degree of protection		IP 21
Colour		RAL 7035 Grey RAL 3005 Maroon
Assembly conditions		
Type of assembly		Vertical
Ventilation		Natural or forced, depending on the option
Distance between capacitors		Minimum, 2 cm
Standards		
CEI 60831-1, CEI 70/7, UNE 20827, UNE 20010, BS 1650, VDE 560		

STANDARD (STD)

Automatic capacitor banks



References

kvar		Composition	Switch (A)	Cable section (mm ²)	Weight (kg)	Dimensions (mm) width x height x depth	Type	Code
440 V	400 V							
7,5	6,2	(2,5 + 5)	63	6	28	290 x 464 x 170	STD3-7.5-440	R36610
12,5	10	(2,5 + 5 + 5)	63	6	28	290 x 464 x 170	STD3-12.5-440	R36620
17,5	14	(2,5 + 5 + 10)	63	10	30	290 x 464 x 170	STD3-17.5-440	R36625
25	21	(5 + (2 x 10))	63	16	31	290 x 464 x 170	STD3-25-440	R36635
31,25	26	(6.25 + (2 x 12.5))	63	16	32	290 x 464 x 170	STD3-31.25-440	R36637
37,5	31,25	(7.5 + (2 x 15))	63	16	33	290 x 464 x 170	STD3-37.5-440	R36639
43,75	36	(6.25 + (3 x 12.5))	100	25	36	460 x 930 x 230	STD4-43.75-440	R34610
50	41	(10 + (2 x 20))	160	25	37	460 x 930 x 230	STD4-50-440	R34615
55	45	(5 + 10 + (2 x 20))	160	35	40	460 x 930 x 230	STD4-55-440	R34620
60	50	(3 x 20)	160	35	40	460 x 930 x 230	STD4-60-440	R34622
70	58	(10 + (3 x 20))	160	50	41	460 x 930 x 230	STD4-70-440	R34630
80	66	(4 x 20)	250	70	41	460 x 930 x 230	STD4-80-440	R34635
87,5	72	(12.5 + (3 x 25))	250	70	43	460 x 930 x 230	STD4-87.5-440	R34636
100	83	(4 x 25)	250	95	46	460 x 930 x 230	STD4-100-440	R34637
105	87	(15 + (3 x 30))	250	95	66	615 X 1330 X 400	STD6-105-440	R3P655
120	99	(4 x 30)	400	95	74	615 X 1330 X 400	STD6-120-440	R3P656
135	112	(15 + (4 x 30))	400	95	81	615 X 1330 X 400	STD6-135-440	R3P657
150	124	(5 x 30)	400	120	82	615 X 1330 X 400	STD6-150-440	R3P658
165	136	(15 + (5 x 30))	400	120	83	615 X 1330 X 400	STD6-165-440	R3P659
180	149	(6 x 30)	400	150	87	615 X 1330 X 400	STD6-180-440	R3P660
195	161	(15 + (6 x 30))	400	150	117	1180 x 1340 x 360	STD12-195-440	R3R700
210	173	(7 x 30)	400	185	119	1180 x 1340 x 360	STD12-210-440	R3R701
225	186	(15 + (7 x 30))	400	185	121	1180 x 1340 x 360	STD12-225-440	R3R702
240	198	(8 x 30)	630	185	124	1180 x 1340 x 360	STD12-240-440	R3R703
255	210	(15 + (8 x 30))	630	240	127	1180 x 1340 x 360	STD12-255-440	R3R704
270	223	(9 x 30)	630	240	130	1180 x 1340 x 360	STD12-270-440	R3R705
285	235	(15 + (9 x 30))	630	240	133	1180 x 1340 x 360	STD12-285-440	R3R706
300	248	(10 x 30)	630	240	136	1180 x 1340 x 360	STD12-300-440	R3R707
315	260	(15 + (10 x 30))	630	240	139	1180 x 1340 x 360	STD12-315-440	R3R708
330	273	(11 x 30)	630	2x150	142	1180 x 1340 x 360	STD12-330-440	R3R709
345	285	(15 + (11 x 30))	800	2x150	145	1180 x 1340 x 360	STD12-345-440	R3R710
360	298	(12 x 30)	800	2x150	155	1180 x 1340 x 360	STD12-360-440	R3R711
330	273	(30 + (5 x 60))	800	2x150	232	1180 x 1650 x 360	STD8-330-440	R3E462
360	298	(6 x 60)	800	2x185	240	1180 x 1650 x 360	STD8-360-440	R3E464
390	322	(30 + (6 x 60))	1000	2x185	245	1180 x 1650 x 360	STD8-390-440	R3E466
420	347	(7 x 60)	1000	2x240	250	1180 x 1650 x 360	STD8-420-440	R3E470
450	372	(30 + (7 x 60))	1000	2x240	255	1180 x 1650 x 360	STD8-450-440	R3E472
480	397	(8 x 60)	1250	2x240	260	1180 x 1650 x 360	STD8-480-440	R3E474
450	372	(50 + (4 x 100))	1000	2x185	270	1180 x 1895 x 460	STD SC8-500-440	R3E499
500	413	(5 x 100)	1000	2x240	275	1180 x 1895 x 460	STD SC8-550-440	R3E500
550	454	(50 + (5 x 100))	1250	2x240	280	1180 x 1895 x 460	STD SC8-550-440	R3E501
600	496	(6 x 100)	1250	2x240	285	1180 x 1895 x 460	STD SC8-600-440	R3E502
650	537	(50 + (6 x 100))	1600	3x150	290	1180 x 1895 x 460	STD SC8-650-440	R3E503
700	579	(7 x 100)	1600	3x150	295	1180 x 1895 x 460	STD SC8-700-440	R3E504
750	620	(50 + (7 x 100))	1600	3x185	300	1180 x 1895 x 460	STD SC8-750-440	R3E505
800	661	(8 x 100)	1600	3x185	305	1180 x 1895 x 460	STD SC8-800-440	R3E506
900	744	(50 + 50 + (8 x 100))	1600 / 400	3x150 / 185	525	2460 x 1895 x 460	STD SC16-900-440	R3E576
950	785	(50 + (9 x 100))	1600 / 400	3x185 / 185	535	2460 x 1895 x 460	STD SC16-950-440	R3E577
1000	826	(10 x 100)	1600 / 400	3x185 / 185	545	2460 x 1895 x 460	STD SC16-1000-440	R3E579
1050	868	(50 + (10 x 100))	1600 / 630	3x185 / 240	555	2460 x 1895 x 460	STD SC16-1050-440	R3E580
1100	909	(11 x 100)	1600 / 630	3x185 / 2x120	565	2460 x 1895 x 460	STD SC16-1100-440	R3E581
1150	950	(50 + (11 x 100))	1600 / 800	3x185 / 2x150	575	2460 x 1895 x 460	STD SC16-1150-440	R3E582
1200	992	(12 x 100)	1600 / 1000	3x185 / 2x185	585	2460 x 1895 x 460	STD SC16-1200-440	R3E583
1300	1074	(13 x 100)	1600 / 1000	3x185 / 2x240	590	2460 x 1895 x 460	STD SC16-1300-440	R3E584
1400	1157	(14 x 100)	1600 / 1250	3x185 / 3x120	595	2460 x 1895 x 460	STD SC16-1400-440	R3E588
1500	1240	(100 + (7 x 200))	1600 / 1600	3x185 / 3x150	600	2460 x 1895 x 460	STD SC16-1500-440	R3E590
1600	1322	(100 + 100 + (7 x 200))	1600 / 1600	3x185 / 3x185	605	2460 x 1895 x 460	STD SC16-1600-440	R3E591

STANDARD (STD)

Automatic capacitor banks



Dimensions

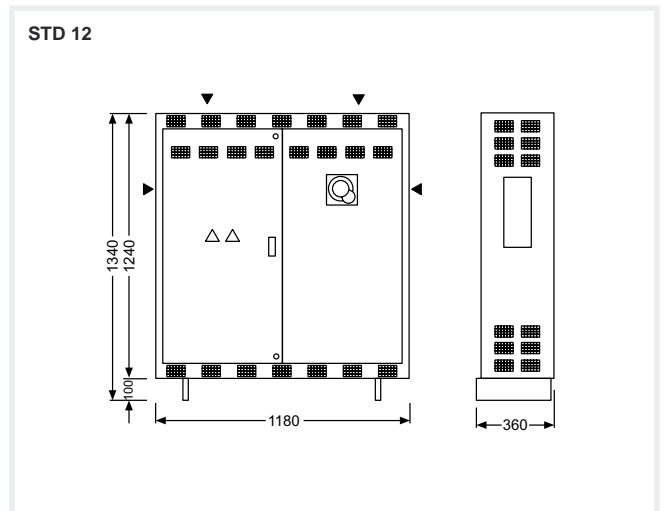
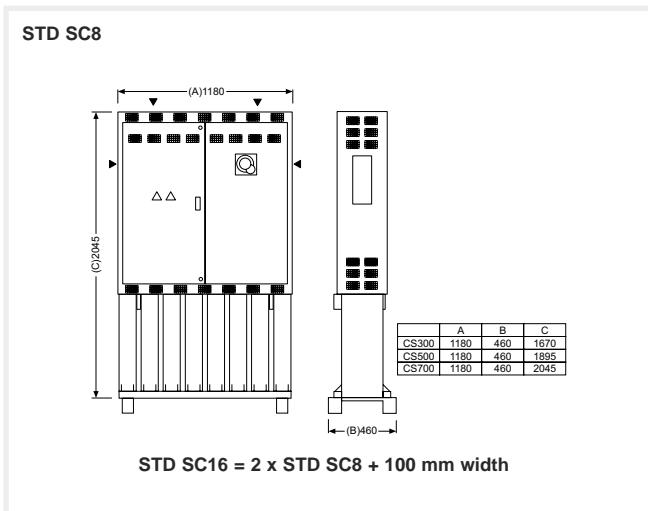
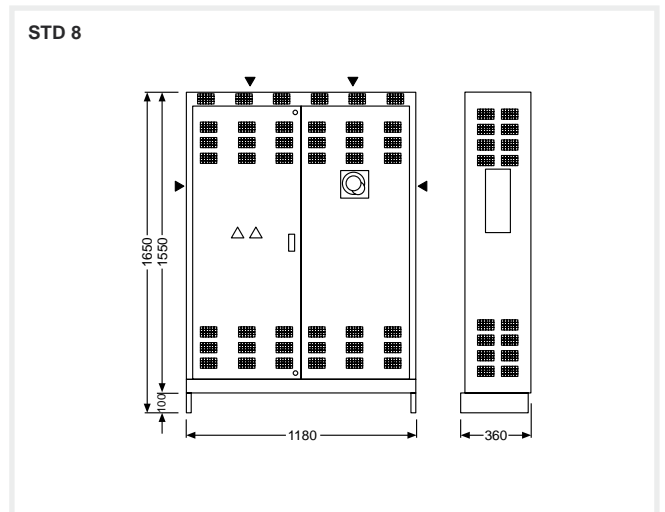
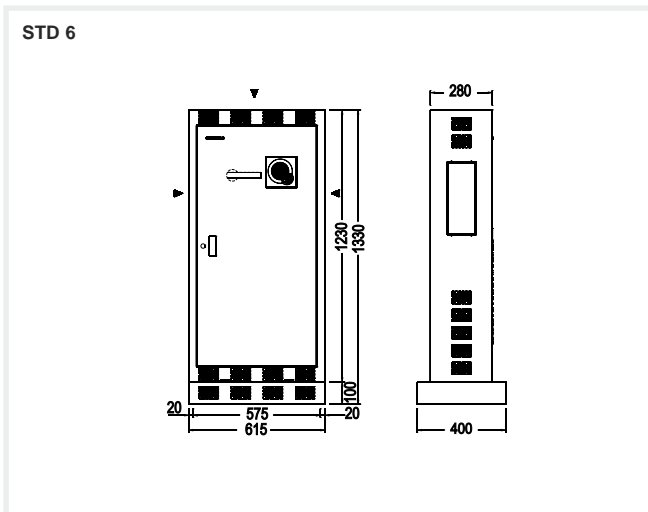
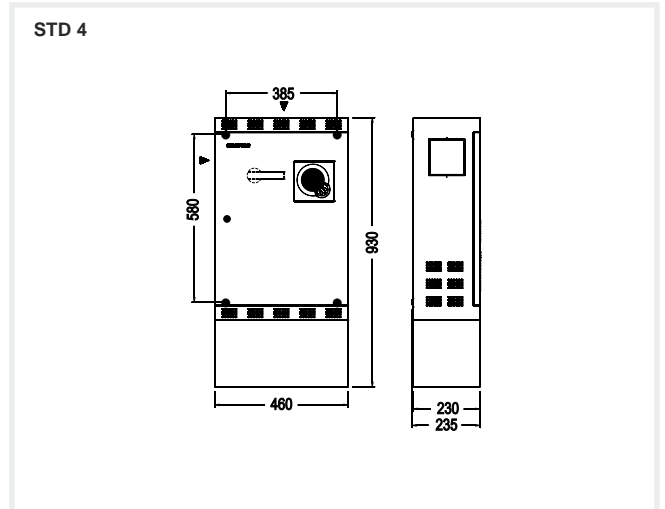
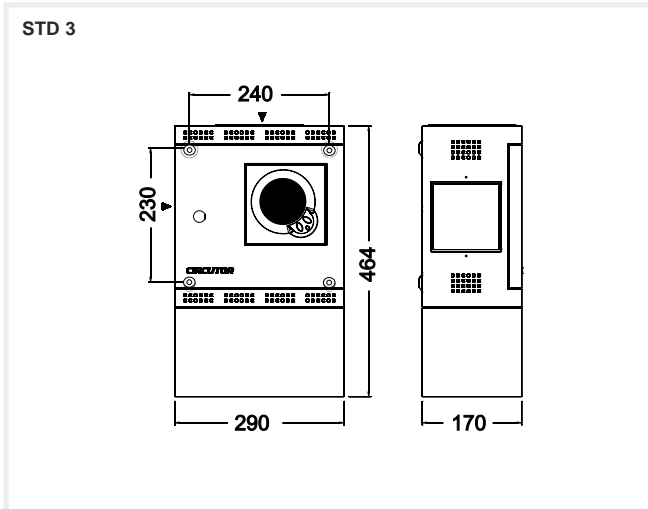

PLUS

Automatic capacitor banks

Description

Capacitor bank with an intelligent state-of-the-art regulator, capable of measuring the three installation phases and compensating the total power factor consumption accurately.

The **PLUS** capacitor bank has been designed with **CIRCUTOR's** measurement system technology, effectively creating a compensation + measurement unit. Its displays any electrical parameter of the network in real time and records it in its internal memory, with maximum and minimum values, date and hour.

- The user can benefit from the following advantages as a result of the many new features: The measurement of the three phases guarantees the real compensation of the installation.
- Protection against harmonics, with an anti-resonance system
- Easy installation, fully self-programmable, operation start-up by pressing just one key
- New regulation program that enables the use of any type of sequence
- Greater continuity of the service, control and display of leakages, with step-by-step earth leakage protection
- Internal temperature sensor, for the protection against excessive temperatures, with alarm and/or disconnection system
- Test function to check the whole unit by pressing just one key
- The communications system can be used by the user to display the distance of unit parameters and the network for the preventive supervision and maintenance tasks.

Application

Its application is mainly focused on the compensation of installations with different loads, which require a regulated compensation, as a result of the power factor variations.



Features

Features		
Operating voltage	230, 400 V (for other voltages, please ask)	
Support voltage	440 V	
Capacity tolerance	0, ± 10%	
Unit composed of	<ul style="list-style-type: none"> • CS, CV ... capacitor • Contactors with pre-insertion block and quick discharge resistor • Individual protection of each step with high rupture power (HRP). NH-00 or Neozed series, depending on the type • Two-pole earth leakage protection system for regulator and capacitor bank switching operations • Power factor regulator of the computer PLUS series, with digital display and 8 or 14 relay outputs, depending on the type: <ul style="list-style-type: none"> - Integral control of the three phases - Power analyzer to monitor $\cos \varphi$, Power factor, P, Q, S and voltage and current harmonics - Alarms for overvoltages, undervoltages, harmonics, temperature and lack of compensation 	
Add-ons	<ul style="list-style-type: none"> • Manual capacitor bank header switch • Automatic capacitor bank header switch • Automatic switch + Earth leakage protection at the capacitor bank's header • Forced ventilation unit + thermostat • Polycarbonate plate to protect against direct contacts • Auto-transformer 400/230 V 	
Insulation level	3 / 15 kV	
Discharge resistance	75 V / 3 minutes	
Overload	1.3 times the rated current permanently	
Overvoltage	<ul style="list-style-type: none"> • 10 % 8 over 24 hours • 15 % up to 15 minutes over 24 hours • 20 % up to 5 minutes over 24 hours • 30 % up to 1 minutes over 24 hours 	
Contactor operating voltage	230 V	
Ambient conditions		
Class D temperature	Daily mean	45 °C
	Annual mean	35 °C
	Maximum	50 °C
	Minimum	-25 °C
Humidity	80 % RH	
Altitude	2,000 m	
Construction features		
Degree of protection	IP 21	
Colour	RAL 7035: Grey / RAL 3005: Maroon	
Assembly conditions		
Type of assembly	Vertical	
Ventilation	Natural or forced, depending on the option	
Distance between capacitors	Minimum, 2 cm	
Standards		
CEI 60831-1, CEI 70/7, UNE 20827, UNE 20010, BS 1650, VDE 560		

PLUS

Automatic capacitor banks



References

kvar	Composition	Switch (A)	Cable section (mm ²)	Weight (kg)	Dimensions (mm) width x height x depth	Type	Code
440 V	400 V						
7,5	6,2 (2,5 + 5)	63	6	32	460 x 930 x 230	PLUS4-7.5-440	R36810
12,5	10 (2,5 + 5 + 5)	63	6	32	460 x 930 x 230	PLUS4-12.5-440	R36820
17,5	14 (2,5 + 5 + 10)	63	6	32	460 x 930 x 230	PLUS4-17.5-440	R36825
25	21 (5 + (2 x 10))	63	16	32	460 x 930 x 230	PLUS4-25-440	R36835
31,25	26 (6.25 + (2 x 12.5))	63	16	32	460 x 930 x 230	PLUS4-31.25-440	R36850
37,5	31,25 (7.5 + (2 x 15))	63	16	32	460 x 930 x 230	PLUS4-37.5-440	R36651
43,75	36 (6.25 + (3 x 12.5))	100	25	36	460 x 930 x 230	PLUS4-43.75-440	R34810
50	41 (10 + (2 x 20))	160	25	37	460 x 930 x 230	PLUS4-50-440	R34815
55	45 (5 + 10 + (2 x 20))	160	35	40	460 x 930 x 230	PLUS4-55-440	R34820
60	50 (3 x 20)	160	35	40	460 x 930 x 230	PLUS4-60-440	R34822
70	58 (10 + (3 x 20))	160	50	41	460 x 930 x 230	PLUS4-70-440	R34830
80	66 (4 x 20)	250	70	41	460 x 930 x 230	PLUS4-80-440	R34835
87,5	72 (12.5 + (3 x 25))	250	70	43	460 x 930 x 230	PLUS4-87.5-440	R34840
100	83 (4 x 25)	250	95	46	460 x 930 x 230	PLUS4-100-440	R34845
105	87 (15 + (3 x 30))	250	95	76	615 X 1330 X 400	PLUS6-105-440	R3P840
120	99 (4 x 30)	400	95	84	615 X 1330 X 400	PLUS6-120-440	R3P844
135	112 (15 + (4 x 30))	400	95	91	615 X 1330 X 400	PLUS6-135-440	R3P846
150	124 (5 x 30)	400	120	94	615 X 1330 X 400	PLUS6-150-440	R3P848
165	136 (15 + (5 x 30))	400	150	96	615 X 1330 X 400	PLUS6-165-440	R3P852
180	149 (6 x 30)	400	150	97	615 X 1330 X 400	PLUS6-180-440	R3P854
195	161 (15 + (6 x 30))	400	150	127	1180 x 1340 x 360	PLUS12-195-440	R3R864
210	173 (7 x 30)	400	185	136	1180 x 1340 x 360	PLUS12-210-440	R3R870
225	186 (15 + (7 x 30))	400	185	143	1180 x 1340 x 360	PLUS12-225-440	R3R872
240	198 (8 x 30)	630	185	150	1180 x 1340 x 360	PLUS12-240-440	R3R876
255	210 (15 + (8 x 30))	630	240	157	1180 x 1340 x 360	PLUS12-255-440	R3R882
270	223 (9 x 30)	630	240	164	1180 x 1340 x 360	PLUS12-270-440	R3R890
285	235 (15 + (9 x 30))	630	240	171	1180 x 1340 x 360	PLUS12-285-440	R3R894
300	248 (10 x 30)	630	240	178	1180 x 1340 x 360	PLUS12-300-440	R3R895
315	260 (15 + (10 x 30))	630	240	185	1180 x 1340 x 360	PLUS12-315-440	R3R896
330	273 (11 x 30)	630	2x150	192	1180 x 1340 x 360	PLUS12-330-440	R3R897
345	285 (15 + (11 x 30))	800	2x150	199	1180 x 1340 x 360	PLUS12-345-440	R3R898
360	298 (12 x 30)	800	2x150	206	1180 x 1340 x 360	PLUS12-360-440	R3R899
330	273 (30 + (5 x 60))	800	2x150	390	1180 x 1650 x 360	PLUS8-330-440	R3E562
360	298 (6 x 60)	800	2x185	405	1180 x 1650 x 360	PLUS8-360-440	R3E564
390	322 (30 + (6 x 60))	1000	2x185	420	1180 x 1650 x 360	PLUS8-390-440	R3E566
420	347 (7 x 60)	1000	2x240	435	1180 x 1650 x 360	PLUS8-420-440	R3E568
450	372 (30 + (7 x 60))	1000	2x240	450	1180 x 1650 x 360	PLUS8-450-440	R3E570
480	397 (8 x 60)	1250	2x240	465	1180 x 1650 x 360	PLUS8-480-440	R3E572
450	372 (50 + (4 x 100))	1000	2x185	232	1180 x 1895 x 460	PLUS SC8-450-440	R3E672
500	413 (5 x 100)	1000	2x240	240	1180 x 1895 x 460	PLUS SC8-500-440	R3E674
550	454 (50 + (5 x 100))	1250	2x240	245	1180 x 1895 x 460	PLUS SC8-550-440	R3E766
600	496 (6 x 100)	1250	2x240	250	1180 x 1895 x 460	PLUS SC8-600-440	R3E770
650	537 (50 + (6 x 100))	1600	3x150	255	1180 x 1895 x 460	PLUS SC8-650-440	R3E772
700	579 (7 x 100)	1600	3x150	260	1180 x 1895 x 460	PLUS SC8-700-440	R3E774
750	620 (50 + (7 x 100))	1600	3x185	265	1180 x 1895 x 460	PLUS SC8-750-440	R3E775
800	661 (8 x 100)	1600	3x185	275	1180 x 1895 x 460	PLUS SC8-800-440	R3E776
900	744 (50 + 50 + (8 x 100))	1600 / 400	3x150 / 185	510	2460 x 1895 x 460	PLUS SC16-900-440	R3E876
950	785 (50 + (9 x 100))	1600 / 400	3x185 / 185	520	2460 x 1895 x 460	PLUS SC16-950-440	R3E877
1000	826 (10 x 100)	1600 / 400	3x185 / 185	530	2460 x 1895 x 460	PLUS SC16-1000-440	R3E879
1050	868 (50 + (10 x 100))	1600 / 630	3x185 / 240	535	2460 x 1895 x 460	PLUS SC16-1050-440	R3E880
1100	909 (11 x 100)	1600 / 630	3x185 / 2x120	540	2460 x 1895 x 460	PLUS SC16-1100-440	R3E881
1150	950 (50 + (11 x 100))	1600 / 800	3x185 / 2x150	545	2460 x 1895 x 460	PLUS SC16-1150-440	R3E882
1200	992 (12 x 100)	1600 / 1000	3x185 / 2x185	550	2460 x 1895 x 460	PLUS SC16-1200-440	R3E883
1300	1074 (13 x 100)	1600 / 1000	3x185 / 2x240	555	2460 x 1895 x 460	PLUS SC16-1300-440	R3E884
1400	1157 (14 x 100)	1600 / 1250	3x185 / 3x120	560	2460 x 1895 x 460	PLUS SC16-1400-440	R3E886
1500	1240 (100 + (7 x 200))	1600 / 1600	3x185 / 3x150	565	2460 x 1895 x 460	PLUS SC16-1500-440	R3E888
1600	1322 (100 + 100 + (7 x 200))	1600 / 1600	3x185 / 3x185	570	2460 x 1895 x 460	PLUS SC16-1600-440	R3E970

PLUS

Automatic capacitor banks



Dimensions

PLUS 4

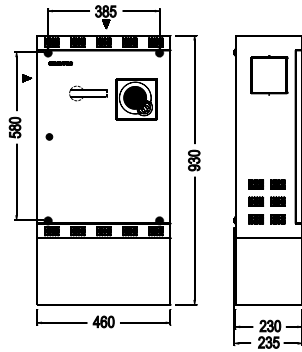

PLUS 6

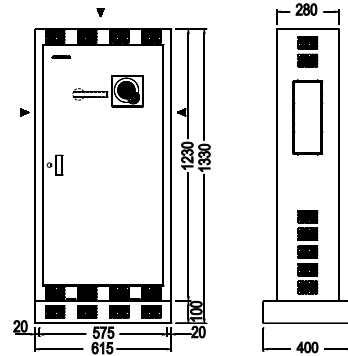

PLUS 8

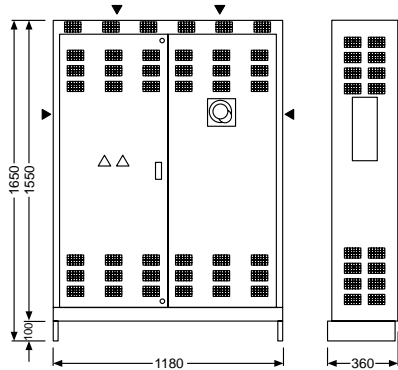

PLUS SC8

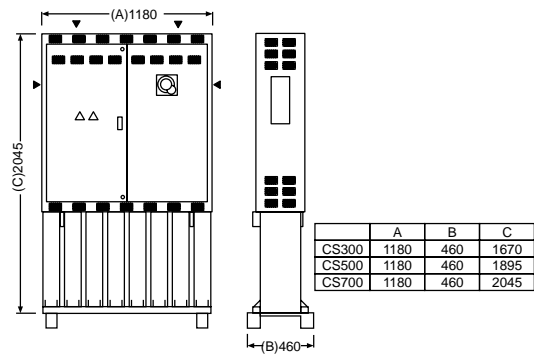

PLUS SC16 = 2 x PLUS SC8 + 100 mm width

PLUS 12

