



3 PHASE ENERGY ELECTRONIC METERS

AM_k-ITF & AM2_k-ITF

(Code 7 71 042 - 7 71 044)

INSTRUCTION MANUAL

(M 981 189 / 00 A)

(c) CIRCUTOR S.A.

3 PHASE ACTIVE & REACTIVE ENERGY ELECTRONIC METERS

1.- BASIC INSTRUCTIONS

1.1.- Delivery spot check

This manual is issued to help all the ENERGY METERS users to install and use them in order to get the best from them. After receiving the unit please check the following points:

- (a) Does this device corresponds to your order specifications?
- (b) Check if any damage was done during the shipment process.
- (c) Verify that it includes: One instruction manual .



1.2.- Safety considerations

This manual contains information and warnings that must be followed for operating the ENERGY METER safely and maintaining the instrument in a safe operating condition.

2.- MAIN CHARACTERISTICS

Three phase electric energy meters for low voltage networks at 400 V a.c. , provided with mechanical rotary display, that are designed to measure the electric energy consumed by any three phase circuit (3 or 4 wires). Those are suitable for such installations where a partial energy consumption analysis is required. Direct connection for the voltage signal (3 x 400 V a.c) and current signal input through external .../5A current transformers.

AVAILABLE MODELS:

- Meter **type AMk- ITF (code 7 71 042)** :

3 phase active energy meter single tariff, input isolated by transformer (... 5 A a.c.). Display by means of an electromecanic integrating meter in kW.h.

- Meter **type AM2k- ITF (code 7 71 044)** :

3 phase active energy meter double tariff, input isolated by transformer (... 5 A a.c.)
Display by means of two electromecanic integrating meters in kW.h. The energy will be accumulated by one or the another meter according to the state of the “tariff changing” input provided in the own meter.

Common features:

- All energy meters have **one pulse outputs**. This output permit a remote transmission of the measurement of the kW.h consumed.

Pulses: open collector type : 100 ms of duration - 24 V d.c. / 30 mA.

Ratio : 1 pulse / 1 kW.h

- **Current transformer ratio** is user-selected by means of mini-dips in the rear side of the energy meter. **SEE PARAGRAPH 3.1.-**

- All energy meters operate over two quadrants: **consumed power**.

- The meter has a **LEDS** at its frontal cover :

- a **Led** of "POWER" : indicates that the meter is connect to supply.
- a **Led** (two for the AM2-ITF model) for the metrology control and the energy flow visualisation. Such led blinks each 1 kW. h

Particular features of the double tariff meter (AM2 - ITF)

- It has an electric input for "tariff change action", that set the energy to be accumulated by one or another meter. This is an optocoupled input (4 kV with respect to the electric network).

The first tariff is assigned by voltage lack between those terminals. Second tariff is selected by applying a 230 Va.c. \pm 10 voltage between those terminals.

3.- INSTALLATION AND STARTUP



The manual you hold in your hands contains information and warnings that the user should respect in order to guarantee a proper operation of all the instrument functions and keep its safety conditions.

The instrument must not be powered and used until its definitive assembly on the cabinet's door.

Whether the instrument is not used as manufacturer's specifications, the protection of the instrument can be damaged.

When any protection failure is suspected to exist (for example, it presents external visible damages), the instrument must be immediately powered off. In this case contact a qualified service representative.

3.1.- INSTALLATION

Before applying AC power to the, check following points :

(a) Power supply is taken from own phases L2-L3 at **400 V a.c. ± 15 %**



(b) Current input of 5 A a.c. (maximum current of 6 A a.c.).
(Overload current of 100 A for half a second).

(c) Frequency : 45 ... 65 Hz

(d) Instrument burden : 0,5 VA

(e) Operation conditions :

- Operating temperature : 0° C / +50° C

- Humidity : 25 to 75 % R.H. noncondensing

(f) Safety : Designed to meet protection class II as per EN 61010.

Mounting:



Instrument is to be mounted onto a DIN rail.

All connections keep inside the cabinet.

Note that with the instrument powered on, the terminals could be dangerous to touching and cover opening actions or elements removal may allow accessing dangerous parts. Therefore, the instrument must not be used until this is completely installed.



The instrument must be connected to a power supply circuit protected with gl type (IEC 269) or M type fuses rated between 0.5 and 2 A. This circuit should be provided with an automatic switch (ON / OFF) or any equivalent element to disconnect the instrument from the power supply network. The supply and measuring voltage circuits will be both connected through a wire with a minimum cross-section of 1 mm². The line of the current transformer secondary will have a minimum cross-section of 2,5 mm².

3.2- CURRENT TRANSFORMER RATIO

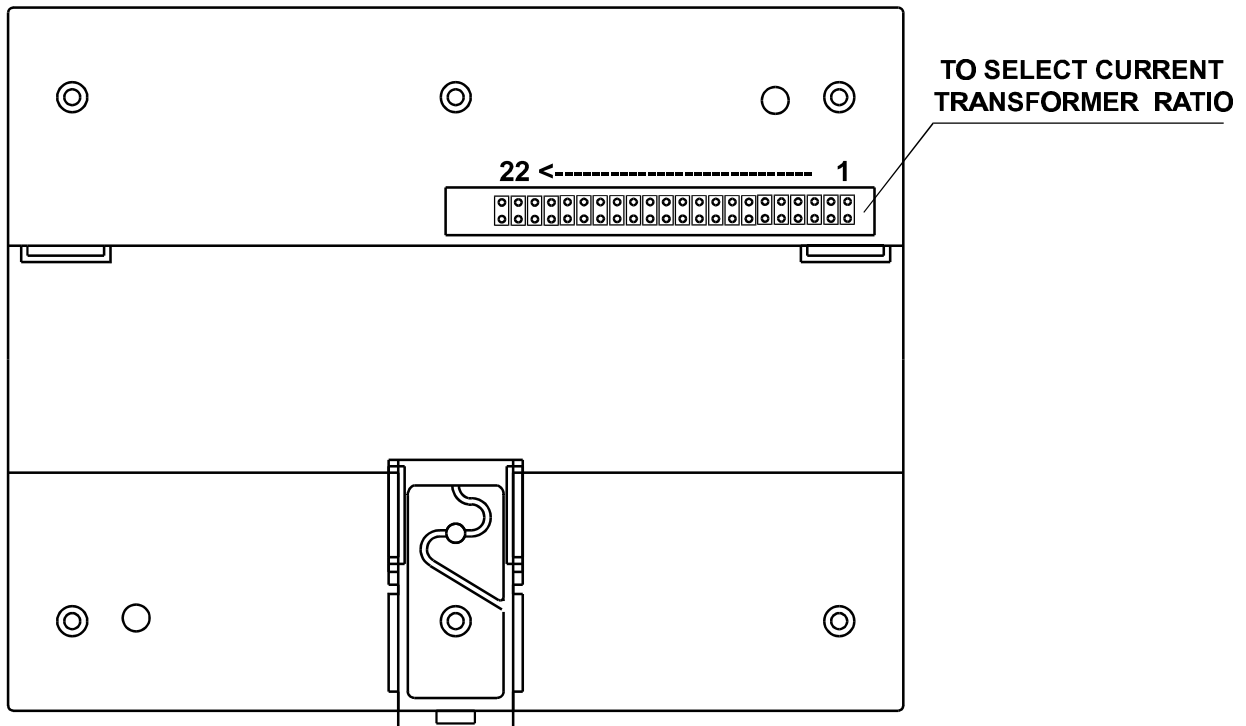
As the rear side of the meter a 22 bridges have been built-in **to select the current transformer ratio** really existing in the installation :



Configuration of the standards current transformer ratios (see table below - 400 V):

 Without bridge &  With bridge

22 <-----	1	
22 21 20 19 18 17 16 15 14 13 12 11 10 9 8 7 6 5 4 3 2 1		
		5 / 5
		10 / 5
		25 / 5
		50 / 5
		75 / 5
		100 / 5
		125 / 5
		150 / 5
		200 / 5
		250 / 5
		300 / 5
		400 / 5
		500 / 5
		600 / 5
		800 / 5
		1000 / 5

22 <-----	1	
22 21 15 14 13 12 11 10 9 8 7 6 5 4 3 2 1		
		1200 / 5
		1250 / 5
		1500 / 5
		2000 / 5
		2500 / 5
		3000 / 5
		4000 / 5
		5000 / 5
		6000 / 5

3.3- ENERGY METER connection terminal

<i>Terminal Nr</i>	<i>Designation</i>	<i>Concept</i>
1	+	Pulse output (+) for active energy
2	--	Pulse output (--) for active energy
3	I1 -	Current input 1S2
4	I1+	Current input 1S1
5	I2 -	Current input 2S2
6	I2+	Current input 2S1
7	I3 -	Current input 3S2
8	I3 +	Current input 3S1
9	N	Neutral N voltage input
10	VL1	Phase 1 voltage input
11	VL2	Phase 2 voltage input
12	VL3	Phase 3 voltage input
13	+	AM2- ITF : a.c. voltage input for tariff change
14	--	AM2- ITF : a.c. voltage input for tariff changing
15 al 28		Not used

¡ **WARNING !** Check following points:

- Correct polarity? Reverse the current transformer placed at this phase.
- Assure that L1, L2 and L3 phases coincide in voltage and current.

3.4.- Connection drawing of the THREE PHASE ENERGY METER in a three phase low voltage mains (with or without neutral wire)

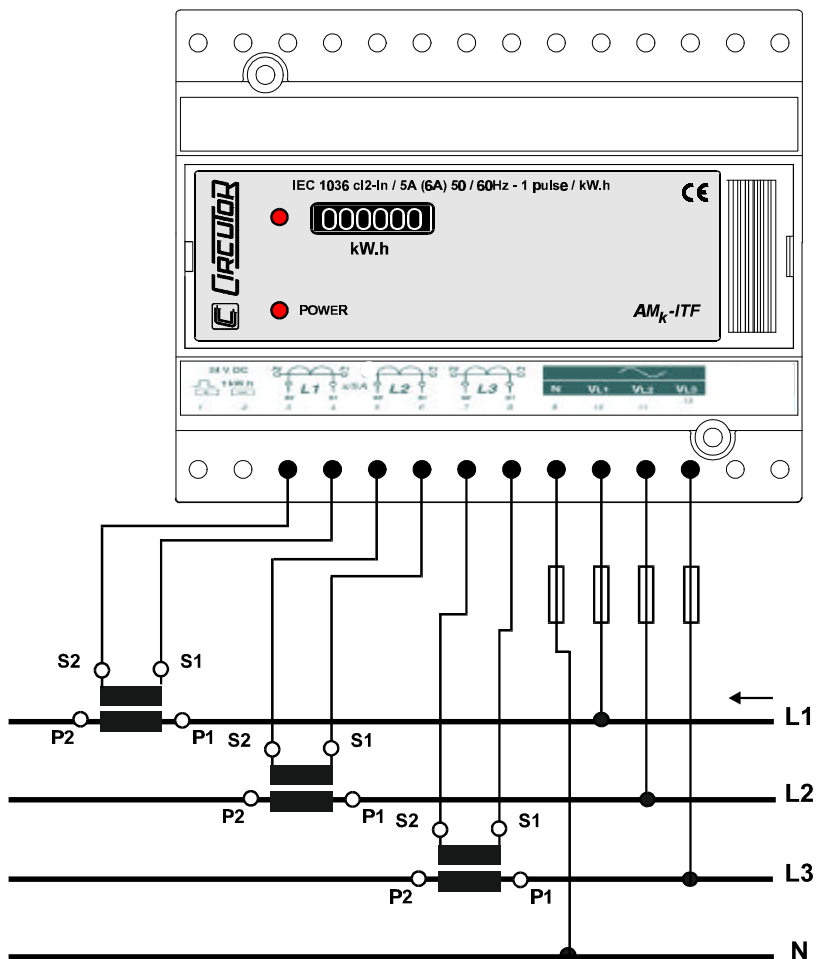

4.- TECHNICAL CHARACTERISTICS

Voltage circuit:

- Rated voltage : 400 V a.c. \pm 15 %
 - Consumption : 0,5 VA
 - Frequency : 45 ... 65 Hz
-

Current circuit:

- Rated base current : ... 5 A a.c. (isolated input in the ITF model)
- Maximum current : 6 A a.c.
- Current input burden : 0.3 VA

The AMk-ITF & AM2k-ITF model energy meters, type.... ITF, have inputs galvanically isolated, either between themselves and with respect to the voltage inputs.

- Connection : Through ... /5 A current transformer
-

Display mode:

- Type : Mechanical rotative (no reset option).
 - Display : 6 digits
 - Digit height : 4 mm
 - Energy units : kW.h
 - Resolution : 1 kW.h
 - Counting range : 999999 kW.h
-

- Accuracy : As per class 2, according to IEC 1036
-

Pulse outputs:

- Nr. of outputs : 1
- Output type : By opto-isolated transistor
- Maximum current : 30 mA
- Maximum voltage : 24 V d.c.
- Pulse sequence : 1 pulse / 1 kW.h
- Pulse duration : 100 ms

Standards : IEC - 1036 , EN-61036, EN-61010

Constructive characteristics :

- Case type : Modular, self-extinguishing plastic
- Connection : Metallic terminals with "posidraft" screws
- Assembly : Fixed onto DIN 46277 (EN 50022) symmetrical rail
- Protection : Built-in relay : IP 41
Terminals : IP 20
- Dimensions : 140 x 70 x 110 mm (8 modules relay as per DIN 43 880)
- Weight : 0.5 kg

Operating temperature: 0 ° C / +50° C

- DIMENSIONS :

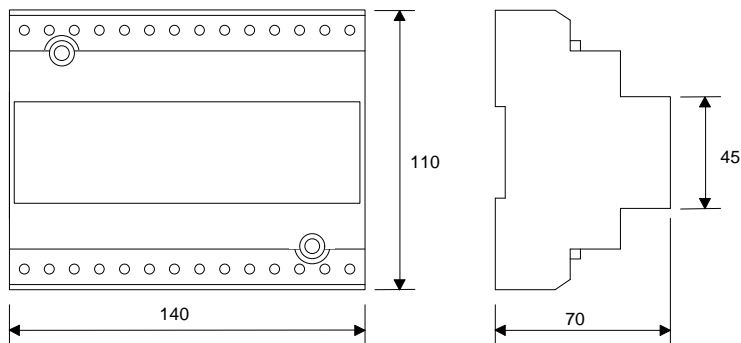

5.- SAFETY CONSIDERATIONS



All installation specification described in this manual must be carefully observed by the user.

Note that with the instrument powered on, the terminals could be dangerous to touching and cover opening actions or elements removal may allow accessing dangerous parts. This instrument is factory-shipped at proper operation condition.

6.- MAINTENANCE

The AM-ITF & AM2-ITF ENERGY METERS do not require any special maintenance. No adjustment, maintenance or repairing action should be done over the instrument open and powered and, should those actions are essential, high-qualified operators must perform them.

Before any adjustment, replacement, maintenance or repairing operation is carried out, the instrument must be disconnected from any power supply source.

When any protection failure is suspected to exist, the instrument must be immediately put out of service. The instrument's design allows a quick replacement in case of any failure.

7.- TECHNICAL SERVICE

For any inquiry about the instrument performance or whether any failure happens, contact to CIRCUTOR's technical service.

*CIRCUTOR S.A. - Aftersales Service
c / Lepanto, 49
08223 - TERRASSA - SPAIN
Tel - 34 - 93 745 29 00
fax - 34- 93 745 29 14
e-mail : central@circutor.es*