



**MULTIPURPOSE
THREE PHASE METER**

CIRWATT-C Series
(Version 1.xx)

Installation Manual
(M98166001-03-04A)

(c) CIRCUTOR S.A.

INSTALLATION MANUAL CONTENTS	Page no.
1.- INTRODUCTION	3
2.- METER MODELS	3
3.- SAFETY LEVELS (Seals).....	3
4.- DISPLAY.....	4
4.1.- Display Modes	4
4.1.1.- STAND BY Mode	4
4.1.2.- READING Mode	4
4.2.- Types of screen.....	5
4.2.1.- Stand by screen.....	5
4.2.2.- Menu Screen.....	5
4.2.3.- Data Screen.....	5
4.3.- STAND BY screen mode.....	6
4.4.- READING screens mode.....	7
4.4.1.- Screen L (Main)	8
4.4.2.- Screen L1(CONTRACT 1, PURCHASE)	8
4.4.3.- Screen L2 (CONTRACT 2, PURCHASE)	13
4.4.4.- Screen L3 (CONTRACT 3, SALE)	14
4.4.5.- Screen L4 (INFORMATION)	15
4.4.6.- Screen L40 (INFORMATION: INDICATORS).....	16
4.4.7.- Screen L5 (Info Fab).....	21
5.- TECHNICAL FEATURES	22
6.- INSTALLATION AND START UP	24
6.1.- Installing the equipment	24
6.2.- Indirect meter terminal ratio (see label on terminal cover)	24
6.3.- Direct meter terminal ratio (see label on terminal cover).....	25
6.4.- Meter connection diagrams	26
7.- MAINTENANCE.....	27
8.- TECHNICAL SERVICE.....	27
A.- CIRWATT communications diagram.....	28
B.- Changing the battery.....	28
C.- Quadrants	29

Index of tables

Table 1 Display Codes.....	5
Table 2 Stand by screen mode.....	6
Table 3 Reading screens mode diagram	7
Table 4 Main menus screen	8
Table 5 Contract 1 screen	8
Table 6 Absolute energy value codes for contract 1.....	9
Table 7 Incremental energy value codes for the meter.	10
Table 8 Absolute energy value codes screen for contract 1 closure 1	11
Table 9 Incremental energy value codes for closure 1 of contract 1	12
Table 10 Absolute values screen for contract 3 closure 1	14
Table 11 Incremental values screen for contract 3 closure 1	15
Table 12 Screen L4. Information.	15
Table 13 Screen L40. Indicators.....	16
Table 14 Screen L41. Contracted powers.	17
Table 15 Screen L42. Transformation ratios	17
Table 16 Screen L43. Information: current values.....	18
Table 17 Screen L44. Instant values	19
Table 18 Screen L45. Communications.....	19
Table 19 Screen L46. Identifiers.....	20
Table 20 Screen L47. Output constants.	20
Table 21 Screen L48. Time changes.....	21

1.- INTRODUCTION.

CIRWATT is a multi-purpose three-phase, four quadrant, digital meter. Its great versatility is its main feature, allowing it to adapt to the needs of each user.

It has been especially designed for installations where the electro-mechanical meters do not meet current requirements. It is specifically for those installations that require a meter with a tariff system or where electricity billing is done by using load profiles.

2.- METER MODEL

The different meter configuration options covering the needs of each installation are shown below:

4 wire	4	Connection mode
Class 0.5S Active / Class 1.0 Reactive	05	Accuracy
Class 1.0 Active / Class 2.0 Reactive	10	
3x57/100V ... 3x230/400V (Multirange)	U	Measured voltage
/1A (Transformer. Maximum 2A effective)	T1	Current measurement
/5A (Transformer. Maximum 10A effective)	T5	
10 A (Direct. Maximum 100A effective)	D1	
Automatic (50/60 Hz)	C	Frequency
Without communications	0	Communications
RS-232	1	
RS-485	2	
Without inputs/outputs	0	Expansion
4 inputs + 3 outputs (optomos)	4	
4 inputs + 3 outputs (relay)	5	
4 inputs + 3 outputs (Optocoupled 24V)	9	
Model: Medium sized industry	C	Model:
Revision	00	

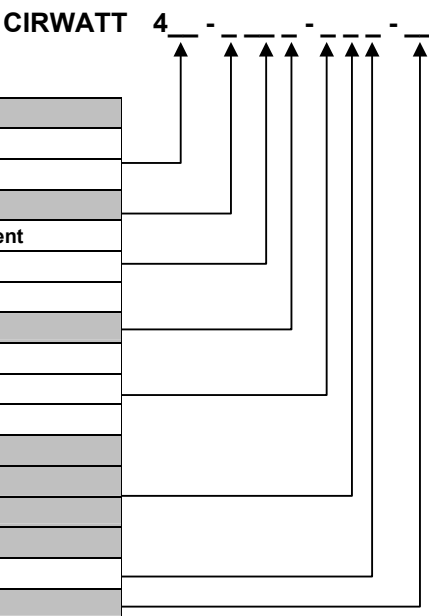

3.- SAFETY LEVELS (Seals)

CIRWATT has the necessary seals to ensure that the meter is **not** tampered with. These seals must always be attached once the meter is installed.

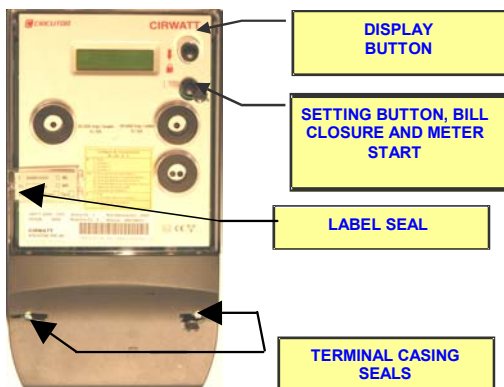

- **Terminal cover seals.** These are attached once the equipment has been installed. These seals prevent the modification of the meter connection.
- **Button seal.** Bill closure and equipment RESET operations are protected by these seals.
- **Label Seal.** This prevents the equipment features label from being changed. (Transformation ratios, integration period, type or market and area of installation).

4.- DISPLAY.

The different menus and/or screens may be displayed by using the key on the CIRWATT. Pressing the ↓ key, for less than 2 seconds (short press), moves through the different active menus on the screen. Pressing the same key (↓) for two seconds (long press), automatically accesses the different secondary options and menus.

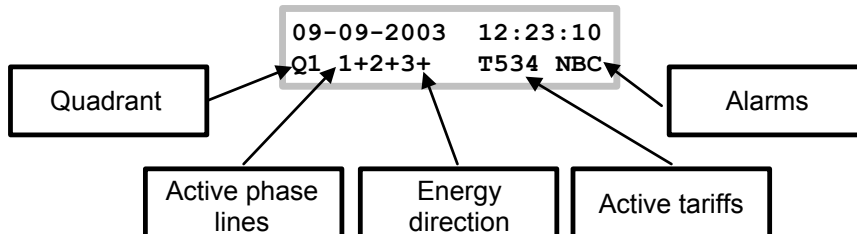

Data is displayed via a one line LCD display especially designed for the CIRWATT.

The units and resolution of the energy values are the same as the overflow values in the meter, i.e. they are the recorder's values. The units will be kWh or kvarh. The size of the records will be 8 whole digits (99.999.999)

The units in which any power and energy data is transmitted by the communications protocol will be kW, kWh, and/or kvarh, independent of what is being displayed.

4.1.- Display Modes.

CIRWATT has different display modes representing different information.

4.1.1.- STAND BY Mode

This will always occur as a default, whenever the READING mode is not activated by pressing or the key not being pressed for 60 seconds even though a menu has been entered.

4.1.2.- READING Mode

This is activated by a long press on the ↓ key, and displays the different options to access data screens or other secondary menu screens. Pressing the ↓ key (short press) moves through the menu, a long press (pressing the ↓ key for 2 seconds) enters the option that is flashing on the screen. 60 seconds after the last press, the Display returns to STAND BY Mode. The different values displayed on this screen are shown in point 4.4 READING screens mode.

Types of screen.
There are three types of screen.

4.1.3.- Stand by screen

The STAND BY screen shows information without the need of using the equipment's key. It will be typically used for showing the customer the necessary information to control the measurement in the easiest way possible. (This is the default screen)

```
09-09-2003 12:23:10
Q1 1+2+3+ T534 NBC
```

4.1.4.- Menu Screen

The MENU screen shows the different options to access the data screens or the other secondary menu screens. It is only used in READING mode.

```
INFO
INFO FAB
```

4.1.5.- Data Screen.

The DATA screens show information on a specific group of data. It is only used in READING mode.

The data lines consist of two fields: one is the code and the other the value of the data. 9 characters are reserved for the code field and the remainder for the value field until the 20 display characters have been used.

```
1.18.1.01 00000003
1.18.2.01 00000009
```



The codes are defined in the following way.

Table 1 Display Codes

Display code		B . CD
B	0 Total	
	1 Contract 1	
	2 Contract 2	
	3 Contract 3	
CD	Energy purchase	Energy sale
	18 Total active energy (kWh)	28 Active energy total (kWh)
	19 Incremental active energy (kWh)	29 Incremental active energy (kWh)
	58 Total Reactive Energy (kvarh)	68 Total Reactive Energy (kvarh)
	59 Incremental reactive energy (kvarh)	69 Incremental Reactive Energy (kvarh)
	16 Maximum demand (kW)	26 Maximum demand (kW)
	12 Power Excesses	22 Power Excesses

Display code		E . F
E	0 Total 1...10 Tariff period	
F	1...6 Bill closures (last - first)	

Pressing for a long time exits a data screen

Pressing for a long time (for 2 seconds) on the  key exits a data screen

4.2.- STAND BY Mode screen

The different values displayed on the STAND BY mode screen are shown below

Table 2 Stand by mode screen

Screens	Text	Type	Comments
R	r.xxxxx P.xxxxx	SCROLL	Link Address and Measurement Point
	0.18.0 XXXXXXXXX		Absolute active energy input total
	0.28.0 XXXXXXXXX		Absolute active energy output total
	0.58.0 XXXXXXXXX		Total Q1 absolute reactive energy
	0.68.0 XXXXXXXXX		Total Q2 absolute reactive energy
	0.78.0 XXXXXXXXX		Total Q3 absolute reactive energy
	0.88.0 XXXXXXXXX		Total Q4 absolute reactive energy
	DD-MM-YYYY HH:MMSS		Date and Local Time
	Alphanumeric indicators' line		
	Q1	Quadrant (Q1, Q2, Q3, Q4) (See APPENDIX C)	
	1+2+3+	Presence of voltage in each phase with its corresponding current direction.	
	T123	Current tariff periods in contracts 1, 2 and 3 respectively.	
	C	Critical alarm due to internal or external incidents directly affecting measurement. This will be flashing.	
N	Non critical alarm not affecting measurement creating a meter malfunction. This will be flashing.		
B	Low battery alarm. This will be flashing.		
P	Special parameter mode activated.		

4.3.- READING screens mode.

READING mode screens consist of different menus as shown below.

Table 3 Reading mode screens diagram

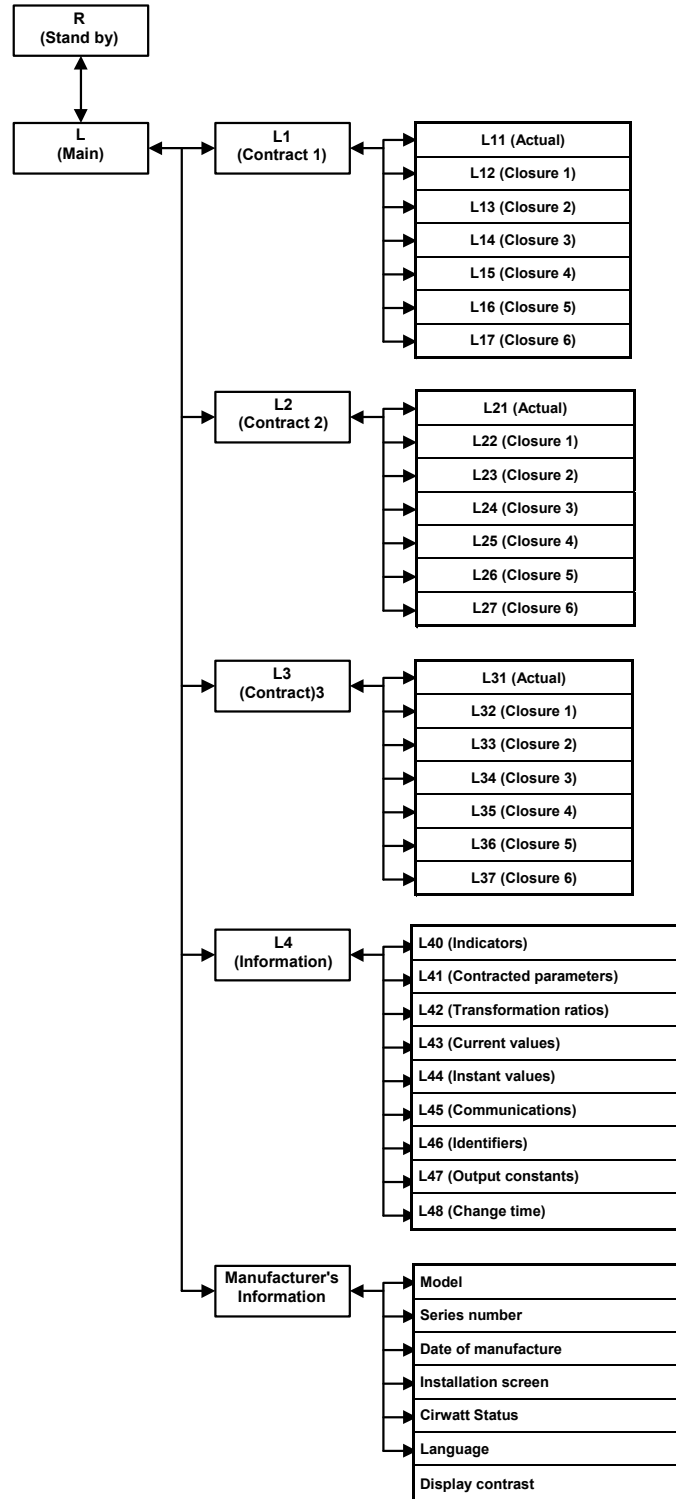

4.3.1.- Screen L (Main)

This is the first screen accessed in READING Mode. It is a MENU screen giving access to other, secondary MENU screens.

Table 4 Main screen menus

Screen	Text	Comments
L	CONTRACT 1	Accesses values for contract 1
	CONTRACT 2	Accesses values for contract 2
	CONTRACT 3	Accesses values for contract 3
	INFO.	Accesses information not relevant to the contracts
	MANU INFO	Accesses additional information defined by the manufacturer
	BACK	Returns to STAND BY screen



CIRWATT allows the setting of any of the three contracts such as PURCHASE or SALE. Below is a possible contract setting that may be changed according to the needs of the USER and/or COMPANY.

4.3.2.- Screen L1 (CONTRACT 1, PURCHASE)

This is the screen that accesses information on contract 1. It is a MENU screen that allows access to other secondary MENU screens.

Table 5 Contract 1 screen

Screen	Text	Comments
L1	CURRENT	Accesses current values for contract 1
	CLOSURE 1 DD-MM-YY	This shows information on values from contract 1 closure 1 (most recent)
	CLOSURE 2 DD-MM-YY	Accesses values for contract 1 closure 2
	CLOSURE 3 DD-MM-YY	Accesses values for contract 1 closure 3
	CLOSURE 4 DD-MM-YY	Accesses values for contract 1 closure 4
	CLOSURE 5 DD-MM-YY	Accesses values for contract 1 closure 5
	CLOSURE 6 DD-MM-YY	Accesses values for contract 1 closure 6 (oldest)
	BACK	Returns to the previous screen

4.3.2.1.- Screen L11 (CONTRACT 1: CURRENT)

This screen shows information on current values for contract 1. On entering this menu two options appear for data display: absolute values and incremental values.

The ABSOLUTE option (**ABS**) displays absolute values for active and reactive energy, as well as power excesses and maximum demands.

The INCREMENTAL option (**INC**) displays the incremental values from the last bill closure for active and reactive energy, power excesses and maximum demands.

If no option is selected, a short press will move on to showing Absolute data values as a default.



Information is only shown on a screen if it is active, i.e. if certain tariffs or powers have not been activated, information on these tariffs, maximum demands or excess power recordings will not appear on the screen.

The codes for Absolute values are shown below:

Table 6 Absolute energy value codes for contract 1.

Screens	Code		Comments
L11	1.18.1	kWh	Tariff periods for Active Energy from the start of measurement (if active), included in the total (period 0) 1.18.x where x = tariff (period)
	1.18.2	kWh	
	1.18.3	kWh	
	1.18.4	kWh	
	1.18.5	kWh	
	1.18.6	kWh	
	1.18.0	kWh	
	1.58.1	kvarh	Tariff periods for Q1 Reactive Energy from the start of measurement (if active), included in the total (period 0) 1.58.x where x = tariff (period)
	1.58.2	kvarh	
	1.58.3	kvarh	
	1.58.4	kvarh	
	1.58.5	kvarh	
	1.58.6	kvarh	
	1.58.0	kvarh	
	1.12.1	Power Excesses	Excesses since the last bill closure (if active) 1.12.x where x = tariff (period)
	1.12.2	Power Excesses	
	1.12.3	Power Excesses	
	1.12.4	Power Excesses	
	1.12.5	Power Excesses	
	1.12.6	Power Excesses	
	1.16.1	Maximums	Maximums from bill closure (if active), included in the total 1.16.x where x = tariff (period)
	1.16.2	Maximums	
	1.16.3	Maximums	
	1.16.4	Maximums	
1.16.5	Maximums		
1.16.6	Maximums		
1.16.0	Maximums		

The codes for the incremental value codes are shown below:

Table 7 Incremental energy value codes for the meter.

Screens	Code	Comments
L11	1.19.1	kWh
	1.19.2	kWh
	1.19.3	kWh
	1.19.4	kWh
	1.19.5	kWh
	1.19.6	kWh
	1.19.0	kWh
	1.59.1	kvarh
	1.59.2	kvarh
	1.59.3	kvarh
	1.59.4	kvarh
	1.59.5	kvarh
	1.59.6	kvarh
	1.59.0	kvarh
	1.12.1	Power Excesses
	1.12.2	Power Excesses
	1.12.3	Power Excesses
	1.12.4	Power Excesses
	1.12.5	Power Excesses
	1.12.6	Power Excesses
	1.16.1	Maximum
1.16.2	Maximums	
1.16.3	Maximums	
1.16.4	Maximums	
1.16.5	Maximums	
1.16.6	Maximums	
1.16.0	Maximums	

Consumption per Active Energy tariff period from the last bill closure (if active) included in the total

1.19.x where x = tariff (period)

Consumption per Q1 Reactive Energy from the last bill closure (if active), included in the total

1.59.x where x = tariff (period)

Excesses from the last bill closure (if active)

1.12.x where x = tariff (period)

Maximums from bill closure (if active), included in the total

1.16.x where x = tariff (period)

4.3.2.2.- Screen L12 (CONTRACT 1: CLOSURE 01)

This shows recorded information from contract 1 during the last closure. The screen acts in the same way as the L11 screen, using Absolute or Incremental values.

Table 8 Absolute energy value codes for contract 1 closure 1

Screens	Code		Comments
L12	1.18.1.01	kWh	Active energy for each tariff period (if active), from the start of measurement until the last closure included in the total (period 0) 1.18.x.01 where x = tariff (period)
	1.18.2.01	kWh	
	1.18.3.01	kWh	
	1.18.4.01	kWh	
	1.18.5.01	kWh	
	1.18.6.01	kWh	
	1.18.0.01	kWh	
	1.58.1.01	kvarh	Q1 Reactive energy for each tariff period (if active), from the start of measurement until the last closure included in the total (period 0) 1.58.x.01 where x = tariff (period)
	1.58.2.01	kvarh	
	1.58.3.01	kvarh	
	1.58.4.01	kvarh	
	1.58.5.01	kvarh	
	1.58.6.01	kvarh	
	1.58.0.01	kvarh	
	1.12.1.01	Power Excesses	Excesses from the last billing period (if active) 1.12.x.01 where x = tariff (period)
	1.12.2.01	Power Excesses	
	1.12.3.01	Power Excesses	
	1.12.4.01	Power Excesses	
	1.12.5.01	Power Excesses	
	1.12.6.01	Power Excesses	
	1.12.0.01	Power Excesses	
	1.16.1.01	Maximums	Maximums from the last billing period (if active) included in the total 1.16.x.01 where x = tariff (period)
	1.16.2.01	Maximums	
	1.16.3.01	Maximums	
1.16.4.01	Maximums		
1.16.5.01	Maximums		
1.16.6.01	Maximums		
1.16.0.01	Maximums		

The variable codes for incremental values are shown below:

Table 9 Incremental energy value codes for closure 1 of contract 1

Screens	Code		Comments
L12	1.19.1.01	kWh	Consumption per Active Energy tariff periods from the last billing period (if active), included in the total (period 0)
	1.19.2.01	kWh	
	1.19.3.01	kWh	
	1.19.4.01	kWh	
	1.19.5.01	kWh	
	1.19.6.01	kWh	
	1.19.0.01	kWh	
	1.59.1.01	kvarh	Consumption per Q1 Reactive Energy tariff periods from the last billing period (if active), included in the total (period 1)
	1.59.2.01	kvarh	
	1.59.3.01	kvarh	
	1.59.4.01	kvarh	
	1.59.5.01	kvarh	
	1.59.6.01	kvarh	
	1.59.0.01	kvarh	
	1.12.1.01	Power Excesses	Excesses from the last billing period (if active)
	1.12.2.01	Power Excesses	
	1.12.3.01	Power Excesses	
	1.12.4.01	Power Excesses	
	1.12.5.01	Power Excesses	
	1.12.6.01	Power Excesses	
	1.12.0.01	Power Excesses	
1.16.1.01	Maximums	Maximums form last billing period (if active) included in the total (period 0)	
1.16.2.01	Maximums		
1.16.3.01	Maximums		
1.16.4.01	Maximums		
1.16.5.01	Maximums		
1.16.6.01	Maximums		
1.16.0.01	Maximums		1.16.x.01 where x = tariff (period)

4.3.2.3.- Screen L13 (CONTRACT 1: CLOSURE 02)

This shows information on values from contract 1 closure 02. The screen acts the same as for L12.

The information is displayed in exactly the same way as in screen L12, but field F will have the value 02 instead of 01.

- For example: 1.18.1.02 → Absolute active energy consumed, from period 1, penultimate bill closure.

4.3.2.4.- Screen L14 (CONTRACT 1: CLOSURE 03)

Shows information on values recorded for contract 1 closure 03. The screen acts in the same way as L12.

The information is displayed in exactly the same way as in screen L12, but field F will have the value 03 instead of 01.

- For example: 1.18.1.03 → Absolute active energy consumed, from period 1, bill closure 3.

4.3.2.5.- Screen L15 (CONTRACT 1: CLOSURE 04)

This shows information on values from contract 1 closure 04. The screen acts the same as for L12.

The information is displayed in exactly the same way as in screen L12, but field F will have the value 04 instead of 01.

- For example: 1.18.1.04 → Absolute active energy consumed, from period 1, bill closure 4

4.3.2.6.- Screen L16 (CONTRACT 1: CLOSURE 05)

This shows information on values from contract 1 closure 05. The screen acts the same way as for L12.

The information is displayed in exactly the same way as in screen L12, but field F will have the value 05 instead of 01.

- For example: 1.18.1.05 → Absolute active energy consumed, from period 1, bill closure 5.

4.3.2.7.- Screen L17 (CONTRACT 1: CLOSURE 06)

This shows information on values from contract 1 closure 06. The screen acts in the same way as L12.

The information is displayed in exactly the same way as in screen L12, but field F will have the value 06 instead of 01.

- For example: 1.18.1.06 → Absolute active energy consumed, from period 1, bill closure 6.

4.3.3.- **Screen L2 (CONTRACT 2, PURCHASE)**

This screen accesses information on contract 2. It acts in the same way as L1.

All data screens that depend on this screen have the value 2 in group B of the code.

4.3.3.1.- Screen L21 (CONTRACT 2: CURRENT)

This shows information on current values for contract 2. It acts in the same way as screen L11, but changes the group B code from 1 to 2. The data shown are the same as the indicators on screen L11.

Data is displayed with zeros to the left to fill up the length of the display.

- For example: 2.16.2 → Absolute, current maximum demand for period 2 and for contract 2.

4.3.3.2.- Screen L22 (CONTRACT 2: CLOSURE 01)

This shows information on the current values for contract 2. It acts in the same way as screen L12, but changes the group B code from 1 to 2. The data shown is the same as that shown on screen L11.

Data is displayed with zeros to the left to fill up the length of the data field display.

- For example: 2.18.2.01 → Absolute active energy consumed, from period 2, penultimate bill closure from contract 2.

4.3.3.3.- Screen L23, L24, L25, L26, L27 (CONTRACT 2: CLOSURES 02 TO 06)

This shows recorded information on values from contract 2 from the closures prior to the last closure. It acts in the same way as screens L13 L17 changes the group B code from 1 to 2.

4.3.4.- **Screen L3 (CONTRACT 3, SALE)**

This screen accesses information on contract 3. It acts the same as screen L11, however the codes change according to the Table 1 Display Codes page 5.

4.3.4.1.- Screen L3-L37 (CONTRACT 3: CURRENT AND CLOSURES 01 TO 06)

Shows information on values recorded for contract 3. A sample screen 31 is shown below:

Table 10 Absolute values screen for contract 3 closure 1

Screen	Code	Comments
L31	3.28.1.01	kWh
	3.28.2.01	kWh
	3.28.3.01	kWh
	3.28.4.01	kWh
	3.28.5.01	kWh
	3.28.6.01	kWh
	3.28.0.01	kWh
	3.68.1.01	kvarh
	3.68.2.01	kvarh
	3.68.3.01	kvarh
	3.68.4.01	kvarh
	3.68.5.01	kvarh
	3.68.6.01	kvarh
	3.68.0.01	kvarh
	3.22.1.01	Power Excesses
	3.22.2.01	Power Excesses
	3.22.3.01	Power Excesses
	3.22.4.01	Power Excesses
	3.22.5.01	Power Excesses
	3.22.6.01	Power Excesses
	3.26.1.01	Maximums
	3.26.2.01	Maximums
	3.26.3.01	Maximums
	3.26.4.01	Maximums
3.26.5.01	Maximums	
3.26.6.01	Maximums	
3.26.0.01	Maximums	

Tariff periods for Active Energy from the start of measurement (if active), included in the total

3.28.x where x = tariff (period)

Tariff periods for Q2 Reactive Energy from the start of measurement (if active), included in the total

3.68.x where x = tariff (period)

Excesses from the last billing period (if active)

1.12.x.01 where x = tariff (period)

Maximums from the bill closure (if active), included in the total

3.26.x where x = tariff (period)

The codes for the incremental value variables are shown below:

Table 11 Incremental values screen for contract 3 closure 1

Screen	Code	Comments	
L31	3.29.1	kWh	Consumption per Active Energy tariff periods from the last billing period (if active), included in the total 3.29.x.01 where x = tariff (period)
	3.29.2	kWh	
	3.29.3	kWh	
	3.29.4	kWh	
	3.29.5	kWh	
	3.29.6	kWh	
	3.29.0	kWh	
	3.69.1	kvarh	Consumption per Q2 Reactive Energy tariff periods from the last billing period (if active), included in the total 3.69.x.01 where x = tariff (period)
	3.69.2	kvarh	
	3.69.3	kvarh	
	3.69.4	kvarh	
	3.69.5	kvarh	
	3.69.6	kvarh	
	3.22.1.01	Power Excesses	Excesses from last billing period (if active) 3.22.x.01 where x = tariff (period)
	3.22.2.01	Power Excesses	
	3.22.3.01	Power Excesses	
	3.22.4.01	Power Excesses	
	3.22.5.01	Power Excesses	
	3.22.6.01	Power Excesses	
	3.26.0	Maximums	Maximums from the last billing period (if active) included in the total 3.26.x.01 where x = tariff (period)
3.26.1	Maximums		
3.26.2	Maximums		
3.26.3	Maximums		
3.26.4	Maximums		
3.26.5	Maximums		
3.26.6	Maximums		
3.26.0	Maximums		

4.3.5.- Screen L4 (INFORMATION)

This screen accesses information not relevant to the contract billing values. This is a MENU screen. It provides access to other dependant MENU screens as shown below:

Table 12 Screen L4. Information.

Screens	Text	Comments
L40	OPERATIONAL INDICATORS	This is used to check the proper working of the equipment in all its main areas during installation or during later, on site checks.
L41	POWER CONTRACTS	This is used to indicate the values of the contracted powers. It is applied to calculate power excesses.
L42	TRANSFORMATION RATIOS	This shows information on transformation ratios.

Screens	Text	Comments
L43	CURRENT VALUES	This shows information on current power, maximum demand, totals and power from the last integration period (15 minutes as a default).
L44	INSTANT VALUES	This shows information on the instant values of different electrical magnitudes.
L45	COMMUNICATIONS	This shows information on the different parameters of the communications ports.
L46	IDENTIFIERS	This shows information on the equipment's different identifiers, included those for the IEC870-5-102 protocol.
L47	OUTPUT CONSTANTS	This shows information on the output impulse values.
L48	TIME CHANGE	This shows information on the dates of the time change.
L49	BACK	Returns to the previous screen.

4.3.6.- Screen L40 (INFORMATION: INDICATORS)

This screen shows information on the operating indicators. It is used to check the proper working of the equipment in all its main areas during installation or during later, on site checks. It is a DATA screen

As these indicators do not belong to a specific contract, but are general data, field B has the value 0.

Table 13 Screen L40. Indicators.

Screen	Text	Code	Comments
L40	INDICATORS	0.13.38	ACTIVE QUADRANT: This indicates the direction of the active or reactive energy or quadrant (1,2,3 or 4) e.g. 0.13.38 1 shows that it is in quadrant 1
		0.12.38	PRESENCE OF VOLTAGE: This indicates the presence of voltage in each phase (123 if there is voltage in all, blank if they do not have voltage)
		0.11.38	CURRENT DIRECTION: This indicates the direction of importation (+) or exportation (-) in each phase (111 if they are imported, 222 if exported, 000 if there is none)
		0.18.128	ACTIVE TARIFF FOR EACH CONTRACT: This indicates the active tariff at the time of reading for each contract (contract 1, contract 2, contract 3)(values form 1 to 9 for each contract e.g.:. 633
		0.96.2.4	PARAMETERISATION MODE: This indicates if the parameterisation mode is enabled (0 disabled, 1 enabled)
		0.96.5.0	ALARMS This indicates the alarms defined in section 4.3. The data field will display the letters CNB, which will become active according to the type of alarm.

4.3.6.1.- Screen L41 (INFORMATION: CONTRACTED POWERS)

This screen shows information on the contracted powers for contract 1. It only applies to power excesses in Contract 1. It is a DATA screen.

Table 14 Screen L41. Contracted powers.

Screen	Text	Code	Comments
L41	CONTRACTED POWERS	B.135.1	This is for the values in kW to 2 decimals of the contracted powers that will be used to calculate excesses
		B.135.2	
		B.135.3	
		B.135.4	
		B.135.5	1.135.x where x = tariff (period), up to 9, in the event that no power has been contracted for a tariff the value shown will be 0
		B.135.6	
		B.135.7	
		B.135.8	
B.135.9	B shows the contract number		

4.3.6.2.- Screen L42 (INFORMATION: TRANSFORMATION RATIOS)

This screen shows information on the transformation ratios. As this data does not correspond to any specific contract but is data general to all, field B will have the value 0. It is a DATA screen.

Table 15 Screen L42. Transformation ratios

Screen	Text	Code	Comments
L42	TRANSFORMATION RATIOS	0.04.2	CURRENT RATIO PRIMARY: This shows the current ratio primary to 1 decimal
		0.04.5	CURRENT RATIO SECONDARY: This shows the current ratio secondary to 1 decimal
		0.04.3	VOLTAGE RATIO PRIMARY: This shows the voltage ratio primary to 1 decimal (compound voltage)
		0.04.6	VOLTAGE RATIO SECONDARY: This shows the voltage ratio secondary to 1 decimal (compound voltage)

4.3.6.3.- Screen L43 (INFORMATION: CURRENT VALUES)

This screen shows information on current power, maximum power, totals and power from the last integration period (15 minutes as a default). As this data does not correspond to any specific contract but is data general to all, field B will have the value 0. It is a DATA screen.

Table 16 Screen L43. Information: current values.

Screen	Text	Code	Comments
L43	CURRENT	0.18.0	TOTAL A+: This shows the current total for Active Energy taken from the system
		0.28.0	TOTAL A-: This shows the current total for Active Energy exported to the system
		0.58.0	TOTAL R1 This shows the current total for Reactive Energy in Quadrant 1
		0.68.0	TOTAL R2: This shows the current total for Reactive Energy in Quadrant 2
		0.78.0	TOTAL R3: This shows the current total for Reactive Energy in Quadrant 3
		0.88.0	TOTAL R4: This shows the current total for Reactive Energy in Quadrant 4
		0.14.0	CURRENT INPUT POWER: This shows the average input power that is being integrated during the current integration period
		0.24.0	CURRENT OUTPUT POWER: This shows the average output power that is being integrated during the current integration period
		0.15.0	LAST PERIOD INPUT POWER: This shows the average input power that is being integrated during the last integration period
		0.25.0	LAST PERIOD OUTPUT POWER: This shows the average output power that is being integrated during the last integration period

4.3.6.4.- Screen L44 (INFORMATION : INSTANT VALUES)

This screen shows information on the instant values of different electrical magnitudes. As this data does not correspond to any specific contract but is data general to all, field B will have the value 0.

Table 17 Screen L44. Instant values

Screen	Text	Code	Comments
L44	INSTANT	0.327.0	VOLTAGE PER PHASE: This shows the instant Voltage values in each phase
		0.527.0	
		0.727.0	
		0.317.0	CURRENT PER PHASE: This shows the instant Current values in each phase
		0.517.0	
		0.717.0	
		0.337.0	COS Φ PER PHASE: This shows the instant values of cos Φ in each phase
		0.537.0	
		0.737.0	
		0.17.0	INSTANT ACTIVE POWER: This shows the instant Active Power in each phase with its sign
		0.37.0	INSTANT REACTIVE POWER: This shows the instant Reactive Power in each phase with its sign
		0.137.0	AVERAGE POWER FACTOR: This shows the average instant Power Factor in the three phases

4.3.6.5.- Screen L45 (INFORMATION: COMMUNICATIONS)

This screen shows information on the different parameters of the communications ports. As this data does not correspond to any specific contract but is data general to all, field B will have the value 0.

Table 18 Screen L45. Communications

Screen	Text	Code	Comments
L45	COMMUNICATIONS	0.00.0	SETTING THE OPTICAL SERIES PORT: 000000n (009600 speed, n parity)
		0.00.1	SETTING THE ELECTRICAL SERIES PORT 1: 000000n (009600 speed, n parity)
		0.00.3	START UP MODE FOR THE ELECTRICAL SERIES PORT 1: It will appear as data for the ASDU 142 of the protocol

4.3.6.6.- Screen L46 (INFORMATION: IDENTIFIERS)

This screen shows information on the equipment's different identifiers, including those for the IEC870 protocol. As this data does not correspond to any specific contract but is data general to all, field B will have the value 0.

Table 19 Screen L46. Identifiers

Screen	Text	Code	Comments
L46	IDENTIFIERS	0.00.5	LINK ADDRESS
		0.00.6	MEASURING POINT ADDRESS
		0.00.7	DATE OF THE COMMUNICATIONS PROTOCOL VERSION: (DD-MM-YY), data from the ASDU 142 of the protocol will be shown
		0.02.0	EQUIPMENT'S FIRMWARE VERSION: data from the ASDU 142 of the protocol will be shown
		0.08.4	INTEGRATION PERIOD OF THE FIRST LOAD CURVE: this shows the integration period in minutes, 60 minutes as a default
		0.08.5	INTEGRATION PERIOD OF THE SECOND LOAD CURVE: this shows the integration period of the second load curve in minutes, 15 minutes as a default

4.3.6.7.- Screen L47 (INFORMATION: OUTPUT CONSTANTS)

This screen shows information on the impulse values of the outputs. As this data does not correspond to any specific contract but is data general to all, field B will have the value 0.

Table 20 Screen L47. Output constants.

Screen n.	Text	Code	Comments	Values
L47	OUTPUT CONST.	0.03.3	OUTPUT 1	Ax Y : x = 1:imported active x = 2 : exported active Y = impulse weight x Y : x= No. of quadrant (reactive quadrant x Y = impulse weight Pow : Power demand meter CxPy : x = Contract No. y = tariff period No. (The output indicates the tariff)
		0.03.4	OUTPUT 2	
		0.03.5	OUTPUT 3	
		0.03.6	OUTPUT 4	

4.3.6.8.- Screen L48 (INFORMATION: TIME CHANGE)

This screen shows information on the dates of the time changes. As this data does not correspond to any specific contract but is data general to all, field B will have the value 0.

Table 21 Screen L48. Time changes.

Screen	Text	Code	Comments
L48	TIME CHANGE	0.00.8	WINTER-SUMMER TIME CHANGE: DD/MM/YY HH:MM
		0.00.9	SUMMER-WINTER TIME CHANGE: DD/MM/YY HH:MM

4.3.7.- **Screen L5 (Manu Info)**

4.3.7.1.- Model:

This screen identifies the model of the equipment. (See section 2.-METER MODEL).

CIRWATT v1.5b
410-UT5C-15C-00

4.3.7.2.- Series Number

This screen identifies the series number of the equipment.

SERIES NUMBER
342336001

4.3.7.3.- Date of Manufacture

This screen identifies the date of manufacture of the equipment.

DATE OF MANUFACTURE
03-09-03

4.3.7.4.- Installation Screen

This screen supplies a reading of the values measured by the CIRWATT and therefore allows a quick check to see if the equipment is properly installed.

V1:230 V2:230 V3:230
I1:2+I2:2+I3:2+ 50HZ

4.3.7.5.- CIRWATT Status

This screen shows the status of the equipment. In the event of a critical alarm going off, the origin of the fault will be shown. For example a voltage fault in phase 3.

CIRWATT STATUS
OPERATION OK!

4.3.7.6.- Language

This screen indicates the pre-set language for the equipment.

LANGUAGE : SPANISH

4.3.7.7.- Contrast

The % display contrast is shown on this screen.

DISPLAY CONTRAST 75%

5.- TECHNICAL FEATURES

The electrical and mechanical design of the CIRWATT has incorporated all applicable standards for electronic meters.

Power supply:	Self supplied	
Nominal voltage:	3x57.7 /100V 3x230/400V +/- 20%	
Consumption:	< 2W y 10VA	
Frequency:	Either 50 Hz/60 Hz	
Operating temperature:	-20 ° C to + 60 ° C	
Measurement Voltage:	Multirange	
Voltage	3x57.7 /100V 3x320/400V	
Other voltages	Via transformers	
Frequency:	Automatic, either 50 Hz or 60 Hz	
Current measurement:	10 A direct (Maximum 100)	
Current	Via current transformers /5A or /1A	
Other currents	Via current transformers /5A or /1A	
90A maximum current	10 A or 2 A (2 x In) for indirect measurement	
Accuracy: (According to model)		
Active Energy:	Class 0.5S or 1 (IEC 60687 and IEC 61268)	
Reactive energy:	Class 2 or 3 (IEC 61268)	
Memory data:	FLASH (non-volatile memory, no batteries required)	
Type:	Rotating, FIFO	
Setting		
File sizes	Events:	8 Kbytes
	Tariffs:	64 Kbytes
	1 st Load curve:	327 Kbytes
	2 nd Load curve:	327 Kbytes
Independent operating life:	Events:	>512 events
	Tariffs:	64 closures, 21 per contract
	1 st Load curve:	213 days (hourly)
	2 nd Load curve:	53 days (1/4 hourly)

Battery:	
Type:	Lithium.
Life:	10 years.
Operation without battery nor voltage:	Maximum 96 hours
Clock:	
Type:	Quartz oscillator/Mains frequency
Margin:	< 0.5 s per day at 25 °C

Inputs:	Free of potential: 60-300 V. AC.
Digital outputs:	Free of potential
Type:	Mechanical, optoMOS or Optocouplers (24V) (According to model)
LED outputs	
Maximum cadence:	20000 pulses / kW.h or kvar.h 1000 pulses /kW.h or Kvrh. (direct measurement)

Safety:	Category III (110 V) according to EN-61010
---------	--

Assembly features:	
Casing:	According to DIN 43859 Standard
Size:	According to DIN 43857 Standard

The technical drawing shows two views of the device. The left view is a front view with a width dimension of 94.5. The right view is a side view with a total width of 176 and a total height of 327. Internal dimensions include a vertical distance of 230 from the top to the start of the base, a base width of 150, and a small offset of 22 from the centerline to the base edge.

Optical Reader:	IEC-61107 for on-site access.
Protocols:	
Series port (According to model):	RS-232 or RS-485 CHANNEL
Tests/Standards:	
EN 60687	Standards on static, active energy meters for alternating current, class 0.5S and 1.0.
EN 61036	
EN 61268	Standards on reactive energy static meters for alternating current class 2.0 and 3.0.
EN 55022	Conducted emissions: Class B Radiated emissions: Class B
EN 61000-4-6	Immunity to RF fields joined to cables (common mode): 10 V
EN 61000-4-8	Immunity to magnetic fields at mains frequency: 30 A/m

6.- INSTALLATION AND START-UP

6.1.- Installing the equipment

The meter has been designed in accordance with the DIN 43857 standard defining the sizes and the mounting points.

	<p>Remember that when the equipment is connected the terminals may be dangerous when touched. Opening the covers or removing parts may give access to pieces that are dangerous when touched. The equipment must not be used until it is fully installed.</p>
---	---

Warning: All connections must be inside the terminal cover.

6.2.- Indirect meter terminal ratio (see label on terminal cover)

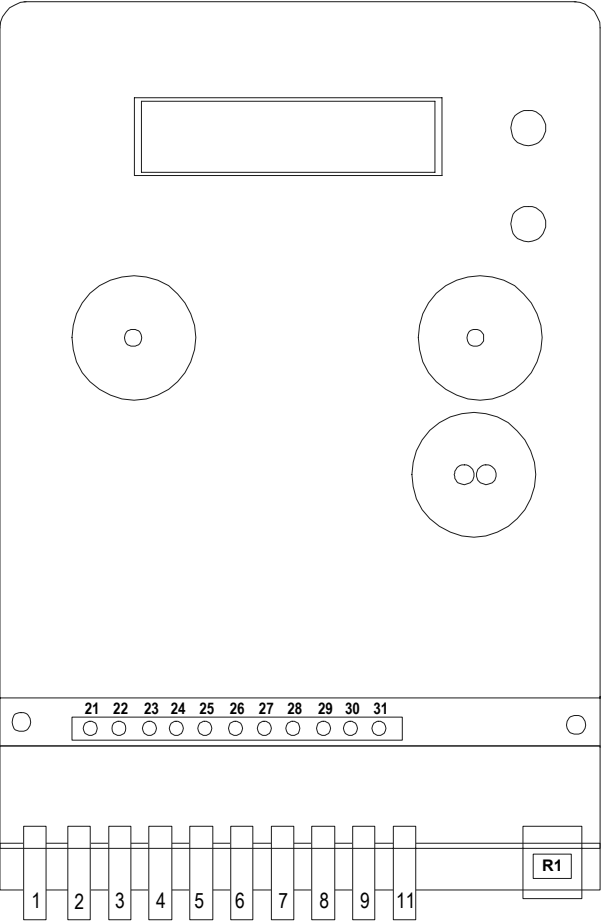
	<p>No. Terminal description</p> <p><u>Lower board</u></p> <p>1 Current input IL1 – S1 2 Measurement UL1 3 Current output IL1 – S2 4 Current input IL2 – S1 5 Measurement UL2 6 Current output IL2 – S2 7 Current input IL3 – S1 8 Measurement UL3 9 Current output IL3 – S2 11 Neutral measurement</p> <p>R1 RS-232 or RS-485 Communications</p> <p><u>Upper board</u></p> <p>21 Relay output 1 22 Relay output 1 23 Relay output 2 24 Relay output 2 25 Relay output 3 26 Relay output 3 27 Input contact 1 28 Input contact 2 29 Input contact 3 30 Input contact 4 31 Input common contact</p>
--	---

NOTE: Current inputs .. /5A or /1A are isolated.

6.3.- Direct meter terminal ratio (see label on terminal cover)

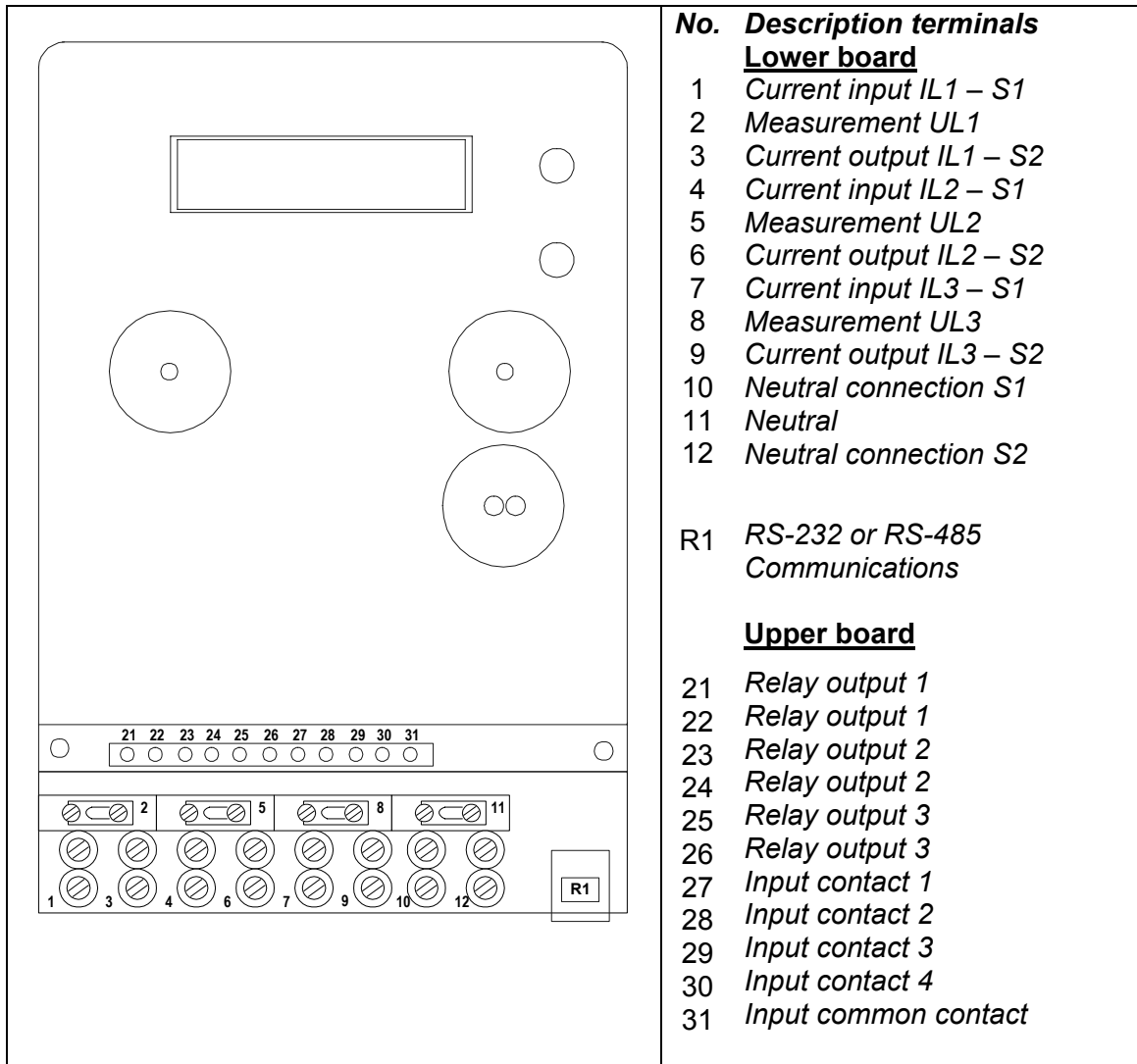

NOTE: The current inputs are isolated.

6.4.- Meter connection diagrams

Each CIRWATT model is especially designed for a different type of three phase system, therefore the connection diagram will vary.

The required connection diagram is located inside the terminal cover

Indirect meters: ... / 5A and ... / 1A

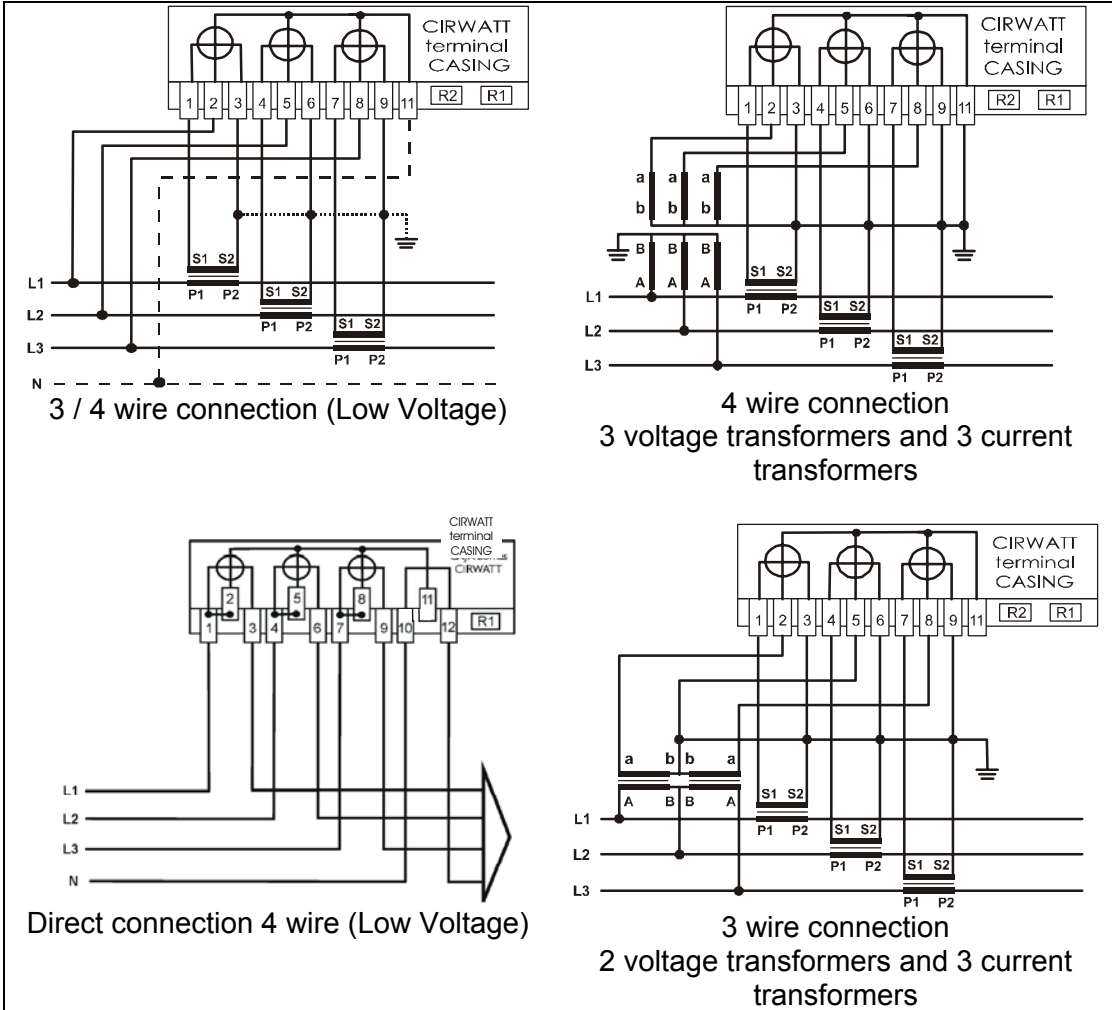

7.- MAINTENANCE

The only maintenance required by the CIRWATT is replacing the battery when it has run out.

<p>It is advised that the battery is changed when the number of hours of use has reached its average working life (10 years).</p>
--

The hours of use may be easily checked via the display.

8.- TECHNICAL SERVICE

In the event of any equipment failure or any operational queries please contact the technical service:

CIRCUTOR S.A. - After sales service.

Vial Sant Jordi, s/n

08232 Viladecavalls

Tel – (+34) 93 745 29 00

Fax - (+34) 93 745 29 14

E-mail - central@circutor.es

A.- CIRWATT connection diagram

It has 1 series port (Plus the optical port): R1: RS-232 or RS-485 port (according to model:) for on site or remote communications → Reading and setting

Connection to a PC

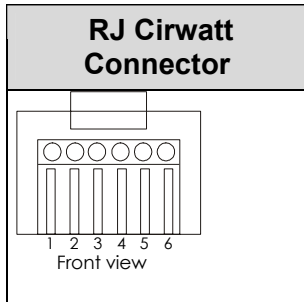

RS-232	
CIRWATT	P.C. (DB9)
1 – GND	5 – GND
2 – RX	3 – Tx
3 – TX	2 – Rx
4 –CTS	7 – CTS
5 – RTS	8 – RTS
6 – GND	5 – GND

RS-485	
CIRWATT	Converter (DB9)
1 – GND	5 – GND
2 –Tx/Rx (-)	2 – Tx/Rx (-)
3–Tx/Rx (+)	1 – Tx/Rx (+)
6 – GND	5 – GND

RS-232 to external Modem.

RJ Cirwatt Connector	CIRWATT	Modem (DB9)	Modem (DB25)
	1 – GND	5 – GND	7 – GND
	2 – Rx	2 – Rx	3 – Rx
	3 – Tx	3 – Tx	2 – Tx
	4 – CTS	7 – CTS	5 – CTS
	5 – RTS	8 – RTS	4 – RTS
	6 – GND	5 – GND	7 – GND

B.- Changing the Battery

Follow the steps below to change the battery:



1. Remove the terminal cover seal”
2. Change the battery.
3. Attach terminal cover.

The battery may be changed with or without the equipment being connected. The equipment has a SUPERCAP that keeps the meter's clock running for 96hours, in the event of the equipment being disconnected.

The battery reference number is written on the cover that holds the battery (CR2477N)

C.- Quadrants

Below is a chart showing the power sign and its corresponding energy quadrant used by the CIRWATT meter.

