



**MULTI-PURPOSE
THREE PHASE METER
CIRWATT Series
TYPE C**

TECHNICAL REPORT

(Revision 1.1)

(c) CIRCUTOR S.A.

Requested by:	Written by:	
CIRCUTOR, S.A.	Ramón Comellas Fusté Collegiate no.: 5354	

1. INTRODUCTION5

2. METER MODELS 7

3. PHYSICAL DESCRIPTION OF THE METER.....8

3.1. Display.....8

3.2. Keyboard9

3.3. Technical details label 10

3.4. Mechanical design 12

3.5. Data storage 13

3.6. Measurement system 14

3.6.1. Base board (power supply and measurement)..... 14

3.6.2. Measurement/power supply circuit. 14

3.6.3. Measurement calculation..... 15

3.7. Input/output module 16

3.7.1. Digital outputs..... 16

3.7.2. Digital inputs..... 16

3.8. Security levels 17

3.8.1. Manufacturers’ seals. 17

3.8.2. Terminals cover seals. 18

3.8.3. Setting, bill closure and meter start up seal 18

3.8.4. Transformer ratios, integration period, market type and area of installation label seal..... 19

3.8.5. Protection of information stored in the memory. 20

4. DESCRIPTION OF THE OPERATION OF THE METER.....21

4.1. Display system..... 21

4.1.1. Standby screen..... 22

4.1.1.1. Critical and non-critical alarms. 25

4.1.1.2. Battery low alarm. 25

4.1.2. Menu screen. 25

4.1.3. Data screen. 26

4.2. Screen description 28

4.2.1. Standby mode Screen..... 28

4.2.1.1. R screen (STANDBY)..... 28

4.2.2. Reading mode Screen..... 28

4.2.2.1. L Screen (SOURCE)..... 30

4.2.2.2. CONTRACT 1 screen..... 30

4.2.2.3. CONTRACT 1 screen: CURRENT..... 30

4.2.2.4. CONTRACT 1: CLOSURE 01..... 31

4.2.2.5. CONTRACT 1 screen: CLOSURE 02..... 32

4.2.2.6. CONTRACT 1 screen: CLOSURE 03..... 32

4.2.2.7. CONTRACT 1 screen: CLOSURE 04..... 32

Requested by:	Written by:	
CIRCUTOR, S.A.	Ramón Comellas Fusté Collegiate no.: 5354	

- 4.2.2.8. CONTRACT 1 screen: CLOSURE 05.....33
- 4.2.2.9. CONTRACT 1 screen: CLOSURE 06.....33
- 4.2.2.10. CONTRACT 2 screen.....33
- 4.2.2.11. CONTRACT 2 screen: CURRENT.....33
- 4.2.2.12. CONTRACT 2 screen: CLOSURE 01.....34
- 4.2.2.13. CONTRACT 2 screen: CLOSURES 02 - 06.....34
- 4.2.2.14. L3 Screen (CONTRACT 3).....34
- 4.2.2.15. CONTRACT 3 screen: CURRENT AND CLOSURES 01 - 06.-
 Importation.....34
- 4.2.2.16. CONTRACT 3 screen: CURRENT AND CLOSURES 01 - 06.-
 Exportation.....35
- 4.2.2.17. Screen L4 (INFORMATION).....35
- 4.2.2.18. INFORMATION screen: INDICATORS.....36
- 4.2.2.19. INFORMATION screen: CONTRACT PARAMETERS.....37
- 4.2.2.20. INFORMATION screen: TRANSFORMATION RATIOS.....37
- 4.2.2.21. INFORMATION screen: VALUES IN PROGRESS.....38
- 4.2.2.22. INFORMATION screen: INSTANT VALUES.....39
- 4.2.2.23. INFORMATION screen: COMMUNICATIONS.....39
- 4.2.2.24. INFORMATION screen: IDENTIFIERS.....40
- 4.2.2.25. INFORMATION screen: OUTPUT CONSTANTS.....40
- 4.2.2.26. INFORMATION screen: TIME CHANGE.....41
- 4.2.2.27. MANUFACTURER’S INFORMATION screen: MODEL.....41
- 4.3. Contracts in Cirwatt.....43
 - 4.3.1. Number and assignment of contracts.....43
 - 4.3.2. Parameters of a contract.....43
 - 4.3.2.1. Activation date.....43
 - 4.3.2.2. Season.....44
 - 4.3.2.3. Types of days.....44
 - 4.3.2.4. Tariff periods. Type of day.....44
 - 4.3.2.5. Powers.....45
 - 4.3.2.6. Bill closures.....45
 - 4.3.3. Maximums.....46
 - 4.3.4. Defined, active and latent contracts.....47
 - 4.3.5. Modification of contracts.....47
 - 4.3.5.1. Modification of an active contract.....48
 - 4.3.5.2. Modification of a latent contract.....48
 - 4.3.6. Deleting contracts.....49
 - 4.3.7. Returning a meter – logger to zero.....49
- 4.4. Inputs and outputs.....50
 - 4.4.1. Digital outputs.....50
 - 4.4.2. Digital inputs.....50
- 4.5. Files.....52
- 4.6. Functions of the keyboard.....53

Requested by:	Written by:	
CIRCUTOR, S.A.	Ramón Comellas Fusté Collegiate no.: 5354	

4.6.1. Unsealed key.53

4.6.2. Sealed key.53

4.7. Load curves54

4.8. Official time change55

4.9. Measurement validation criteria56

4.9.1. Setting the clock with > T1 = 30 seconds deviation.....56

4.9.2. Setting the clock with > T10 minutes deviation.....56

4.9.3. Communications fault between meter and logger.....56

4.9.4. No power supply in at least one phase.56

5. VERIFICATION (IMPULSE LEADS)57

6. COMMUNICATIONS58

7. REAL TIME CLOCK.....59

8. LITHIUM BATTERY60

9. TECHNICAL FEATURES.....61

10. INSTALLATION AND START UP.....64

10.1. Installing the equipment64

10.2. Indirect meter terminal ratios (see label on terminal cover).....65

10.3. Indirect meter terminal ratios (see label on terminal cover).....66

10.4. Meter connection diagram67

10.4.1. 4 wire connection, indirect model.....67

10.4.2. 4 wire connection direct model.....68

11. MECHANICAL PLANS69

12. REPORTS ON TESTS MADE.....70

Requested by:	Written by:	
CIRCUTOR, S.A.	Ramón Comellas Fusté Collegiate no.: 5354	

1. INTRODUCTION

The C Type CIRWATT is a multi-purpose three-phase, four quadrant, digital meter with class 0.5S or 1.0 in active energy measurement and class 1.0 or 2.0 in reactive energy measurement.

It has been especially designed for installations where the electro-mechanical meters do not meet the current requirements. It is specifically for those installations that require a meter with a tariff system or where electricity billing is done by using load profiles.

The CIRWATT meets the existing standards applied to electronic meters and has an independent data retention system that avoids data loss in the absence of power supply.

Below are some of the main features that will be more fully described later:

- **Power supply:** It has been designed so that the equipment always operates when there is voltage between the system wires (self-supplied).
- **Voltage measurement:** Multi-range in voltage, guaranteeing the system measurement classes from 3x57.7V to 3x230V.
- **Current measurement:** This can be done via current transformers /5A or /1A ($I_{\max} = 2 \cdot I_N$) ratio or via direct connection with a maximum effective range of 100A.
- **Operating frequency:** The self-detecting system frequency allows it to operate in any 50Hz or 60Hz system.
- **Accuracy:** The CIRWATT has the following accuracy classes: class 0.5S (IEC60687) or 1.0 in active energy (IEC 61036) and class 1.0 or 2.0 in reactive energy (IEC 61268).
- **Data memory:** It has a FLASH memory (batteries not required) and it is rotating (once it is full, it will record over the oldest data). The memory is organised into three files: load profiles (two profiles for independent loads), tariffs and events.
- **Clock:** The CIRWATT has a real time clock and a synchronisation system with the system frequency. In both cases an error below 0.5 seconds/day at 25 °C is guaranteed.
- **Battery:** The clock and the RAM memory work off a lithium battery with a working life of 10 years (at 25°C). It has to be highlighted that it is easy to replace without the need to disconnect the equipment. It also has a capacitor able to store the RAM data and store the clock in real time for more than 4 days.

Requested by:	Written by:	
CIRCUTOR, S.A.	Ramón Comellas Fusté Collegiate no.: 5354	

- **Communications:** It has 2 channels for transmitting information, meaning that the meter can be adapted to any type of situation: on site reading or remote reading. The first port is an optical interface and the second may be either RS-232 or RS-485 according to the model.
- **Digital inputs and outputs:** It has digital inputs and outputs that allow the expansion of the uses of the meter.
- **Impulse LEDs:** These are used to verify active and reactive energy and for indirect meters with a cadence of 20,000 pulses/kWh and 20,000 pulses/kvarh respectively. For direct meters (without external transformers) the cadence is 1,000 pulses/kWh for measuring active energy and 1,000 pulses/kvarh for reactive energy measurement.
- **Safety:** The equipment has been designed with the necessary seals to ensure against it being handled by unauthorised persons. It meets all safety, immunity and emission standards.
- **Construction features:** The casing has been designed to meet the DIN 43859 standard and its size to meet DIN 43857.

Requested by:	Written by:	
CIRCUTOR, S.A.	Ramón Comellas Fusté Collegiate no.: 5354	

2. METER MODELS

Below are the configuration options for each installation:

Configuration Option	Code	Feature
4 wires	4	Connection mode
Class 0.5S Active / Class 1.0 Reactive	05	Accuracy
Class 1.0 Active / Class 2.0 Reactive	10	
3x57V ... 3x230/400V (Multi-range)	U	Voltage measured
/1A (Transformer. Maximum 2A effective)	T1	Current measured
/5A (Transformer. Maximum 10A effective)	T5	
10A (Direct. Maximum 100A effective)	D1	
Automatic (50/60Hz)	C	Frequency
Without communications	0	Communications
RS-232	1	
RS-485	2	
Without inputs/outputs	0	Expansion
4 inputs + 3 outputs (optomos)	4	
4 inputs + 3 outputs (relay)	5	
4 inputs + 3 outputs (24V opto-coupler)	9	
Medium sized industry model	C	Model
Revision	00	

Requested by:	Written by:	
CIRCUTOR, S.A.	Ramón Comellas Fusté Collegiate no.: 5354	

3. PHYSICAL DESCRIPTION OF THE METER

Below is a physical description of the different parts in the CIRWATT:



3.1. DISPLAY

Data is presented via a LCD display with two lines of 20 characters each. Here all information is displayed, for example: energy meters, electrical parameters, status indicators, etc.

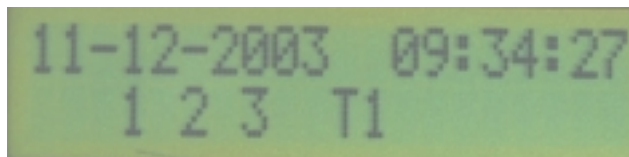

Requested by:	Written by:	
CIRCUTOR, S.A.	Ramón Comellas Fusté Collegiate no.: 5354	

3.2. KEYBOARD

The equipment has two buttons that allow the CIRWATT's display and set-up parameters to be managed. One of these is sealed and is used to block non-authorized operations by the end user, such as bill closures, starting the meter and opening special programs (for example, transformer ratios).

The other button is completely accessible to the user and allows the different information screens to be browsed.

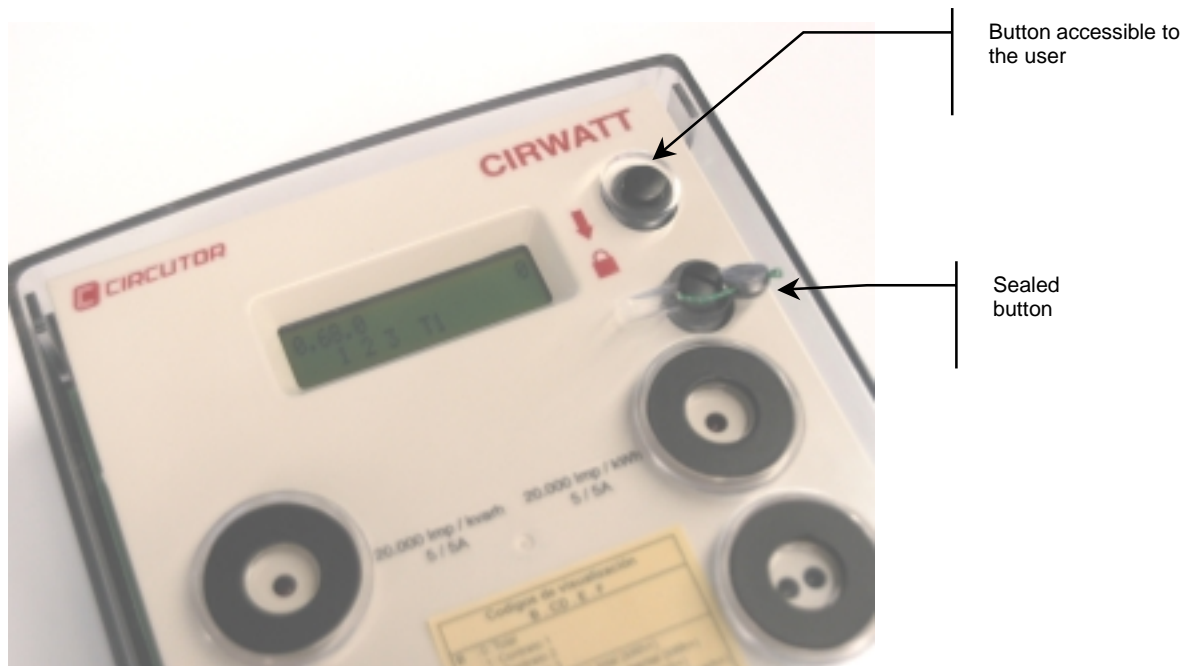

They operate by using the short press-long press system. A short press is one that lasts for less than 2 seconds. While a long press lasts more than 2 seconds

Requested by:	Written by:	
CIRCUTOR, S.A.	Ramón Comellas Fusté Collegiate no.: 5354	

3.3. TECHNICAL DETAILS LABEL

On the front of the meter is the technical details label, showing the following information:

- **Active energy ① and reactive energy ② pulse ratios:** This defines the frequency at which the two LEDs (active and reactive energy) flash. For indirect meters this ratio is 20,000 impulse/kWh and 20,000 impulses/kvarh. The 5/5 A sign shows that this ratio is defined in respect to the power it is measuring in the transformer secondary. In 100A direct meters the ratio is 1,000 impulses/kWh and 1,000 impulses/kvarh
- **Operating features ③:** This part of the label describes: the operating voltage, frequency, nominal current and accuracy of the active and reactive energy measurement.
- **Measurement features ④:** The measurement transformers used for connecting to the installation are described. These values correspond to the programs in the meter. It will also show the integration period of maximum demand (if used).
- **Year of manufacture ⑤:** The year in which the meter was manufactured.
- **Series number ⑤:** The unique identity number for each meter.
- **Bar code ⑤:** Bar code to identify the meter. Its specifications have been defined by UNESA.
- **Model identifier ⑥:** Manufacturer's code to identify the model. By using this code its configuration may be known: power supply, current measured, measurement system, if it has an expansion card and the model, etc.
- **Meter symbols ⑦:** Symbols showing conformity to EC isolation and measurement method standards.
- **Display codes ⑧:** Summary of display codes in accordance with IEC/UNE-EN 62056-61 OBIS standard.
- **Optical port ⑨:** This complies with the mechanical and electrical specifications of the IEC 61107 standard.

Requested by:	Written by:	
CIRCUTOR, S.A.	Ramón Comellas Fusté Collegiate no.: 5354	



Requested by:	Written by:	
CIRCUTOR, S.A.	Ramón Comellas Fusté Collegiate no.: 5354	

3.4. MECHANICAL DESIGN

The CIRWATT casing comes under the DIN 43859 standard and its size complies with the DIN 43857 standard.

The internal design of the CIRWATT is notable for its great strength and simplicity. It comprises two printed circuit boards:

- **Base board:** On the board there are all the components for electrical measurement, communications and protective parts.

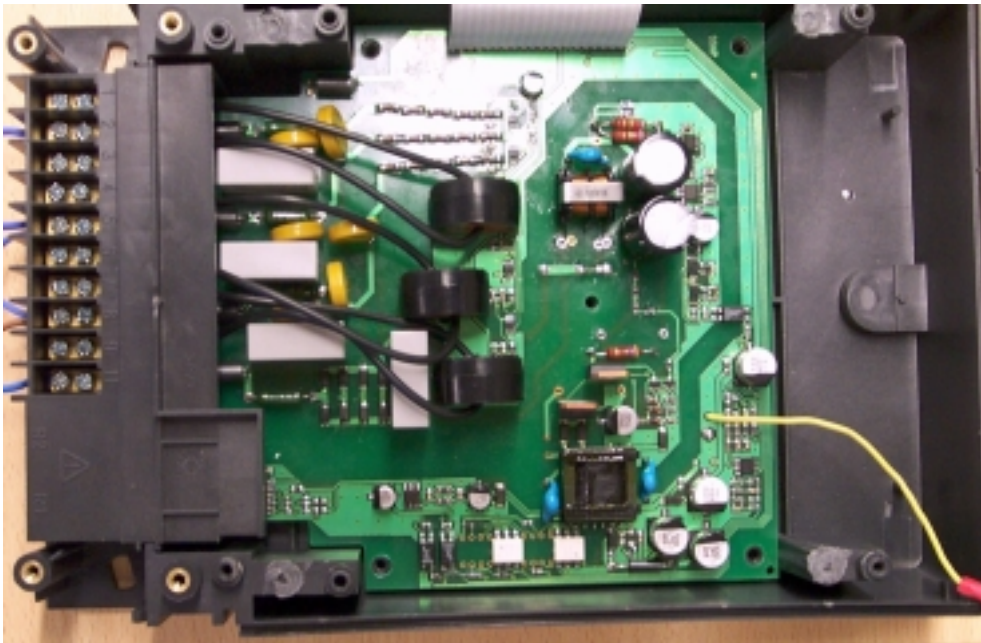

Requested by:	Written by:	
CIRCUTOR, S.A.	Ramón Comellas Fusté Collegiate no.: 5354	

- **Logic board:** all processing, control and display electronics are contained here. There are also the buttons, optical interface and the optional inputs/outputs. It is a multi-layer board that makes it highly immune to electro-magnetic interference. Its SMD assembly also increases the reliability of the equipment.

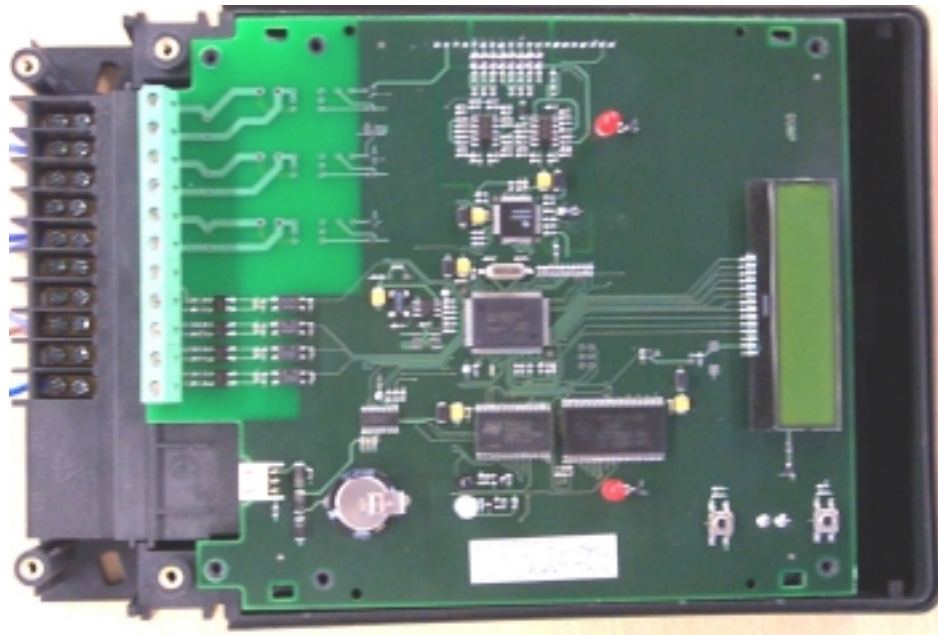

3.5. DATA STORAGE

To store data, the CIRWATT two, completely differentiated memory areas:

- **Program memory:** The CIRWATT program is recorded on the internal FLASH memory of the microprocessor.
- **Data memory:** This memory stores all the useful information for control and billing. The energy meters (bill closures), load profiles and events are stored here. This memory is also a FLASH memory and ensures that data is kept when there is no power supply.

Requested by:	Written by:	
CIRCUTOR, S.A.	Ramón Comellas Fusté Collegiate no.: 5354	

3.6. MEASUREMENT SYSTEM

The measurement system for the CIRWATT multi-purpose three-phase meter is described below.

3.6.1. *Base board (power supply and measurement).*

This printed circuit board houses the measurement and power supply for the meter as well as the communications and input protection.

3.6.2. *Measurement/power supply circuit.*

The meter is supplied via a voltage input (self-supplying). Many of the measurement features also affect the power supply.

- **Measurement:** It has a high degree of protection against external events. This protection prevents the meter suffering any damage from transients, voltage surges or overloads in the current circuit. A +/-20% voltage from the nominal will not affect the proper working of the meter and the measurements made are guaranteed to be correct.
- **Power supply:** The meter will always continue working when the Phase-Neutral or voltage between phases is up to 20% less than the minimum nominal operating voltage.

Requested by:	Written by:	
CIRCUTOR, S.A.	Ramón Comellas Fusté Collegiate no.: 5354	

3.6.3. Measurement calculation.

Processing voltage and current signals is done via a 16-bit converter (± 32768 points) and a 16 bit at 20 MHz microprocessor. These parts offer high power, speed and accurate calculations.

The equipment has a system of meters to calculate energy. These meters add up the energy consumed and generated by the installation. There are 6 energy totalisers (3 for consumption and 3 for generation). This information is detailed per phase and three phase:

- 4 active energy generated meters (L1, L2, L3 y III)
- 4 active energy consumed meters (L1, L2, L3 y III)
- 4 inductive energy generated meters (L1, L2, L3 y III)
- 4 inductive energy consumed meters (L1, L2, L3 y III)
- 4 capacitive energy generated meters (L1, L2, L3 y III)
- 4 capacitive energy consumed meters (L1, L2, L3 y III)

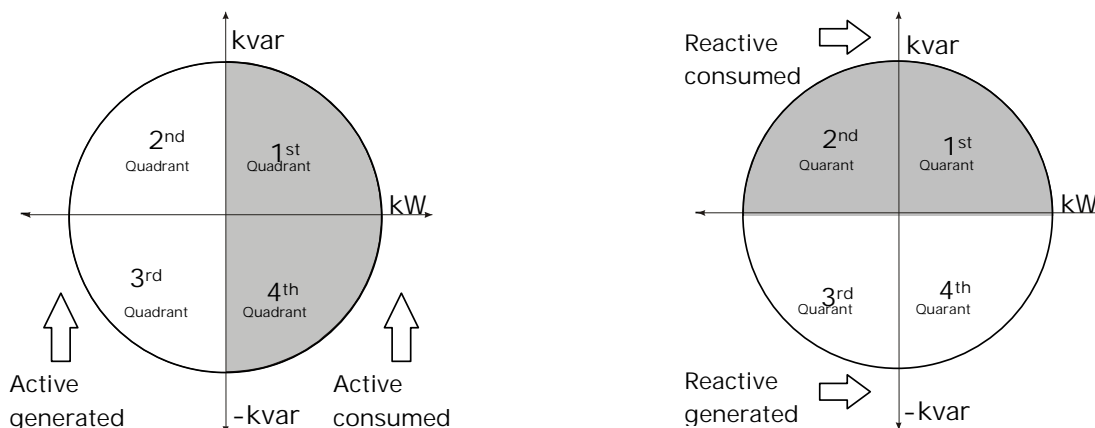

The equipment also calculates the following electrical parameters:

- Phase voltage 1, 2 and 3.
- Phase current 1, 2 and 3.
- Frequency in phase 1.
- Power factors in phases 1, 2 and 3.
- Active power in phases 1, 2, 3 and three phase.
- Reactive power in phases 1, 2, 3 and three phase.
- Apparent power in phases 1, 2, 3 and three phase.

Requested by:	Written by:	
CIRCUTOR, S.A.	Ramón Comellas Fusté Collegiate no.: 5354	

3.7. INPUT/OUTPUT MODULE

This is located on the CPU board and is an optional fitting. It is not necessary for the proper working of the meter.

3.7.1. *Digital outputs.*

The CIRWATT has 3 digital free of potential outputs. There are three relays that may be fitted:

- **Mechanical relays.**
 - Maximum operating power: 1,500 W.
 - Maximum operating voltage: 400 V AC.
 - Maximum operating current: 6 A AC.
 - Mechanical life: $30 \cdot 10^6$ operations.
 - Switch speed: low.
- **Solid state relays (optomos types).**
 - Maximum operating voltage: 400 V AC.
 - Maximum operating current: 150 mA AC.
 - Mechanical life: unlimited.
 - Switch speed: high.
- **Opto-coupler.**
 - Maximum operating voltage: 24 V DC.
 - Maximum operating current: 100 mA DC.
 - Mechanical life: unlimited.
 - Switch speed: high.

3.7.2. *Digital inputs.*

The CIRWATT has 4 digital inputs with one common, free of potential and opto-isolated.

Requested by:	Written by:	
CIRCUTOR, S.A.	Ramón Comellas Fusté Collegiate no.: 5354	

3.8. SECURITY LEVELS

The CIRWATT three-phase meter has the necessary seals to guarantee that no part of the meter is used by any unauthorised person.

3.8.1. Manufacturers' seals.

Once the meter is manufactured and checked, the manufacturer attaches these seals to prevent any of the meter's electronics being used. To reach this seal it is necessary to first unseal the terminal cover.



Requested by:	Written by:	
CIRCUTOR, S.A.	Ramón Comellas Fusté Collegiate no.: 5354	

3.8.2. Terminals cover seals.

These seals are attached once the equipment has been fitted. These seals will prevent the modification of the meter’s connection.

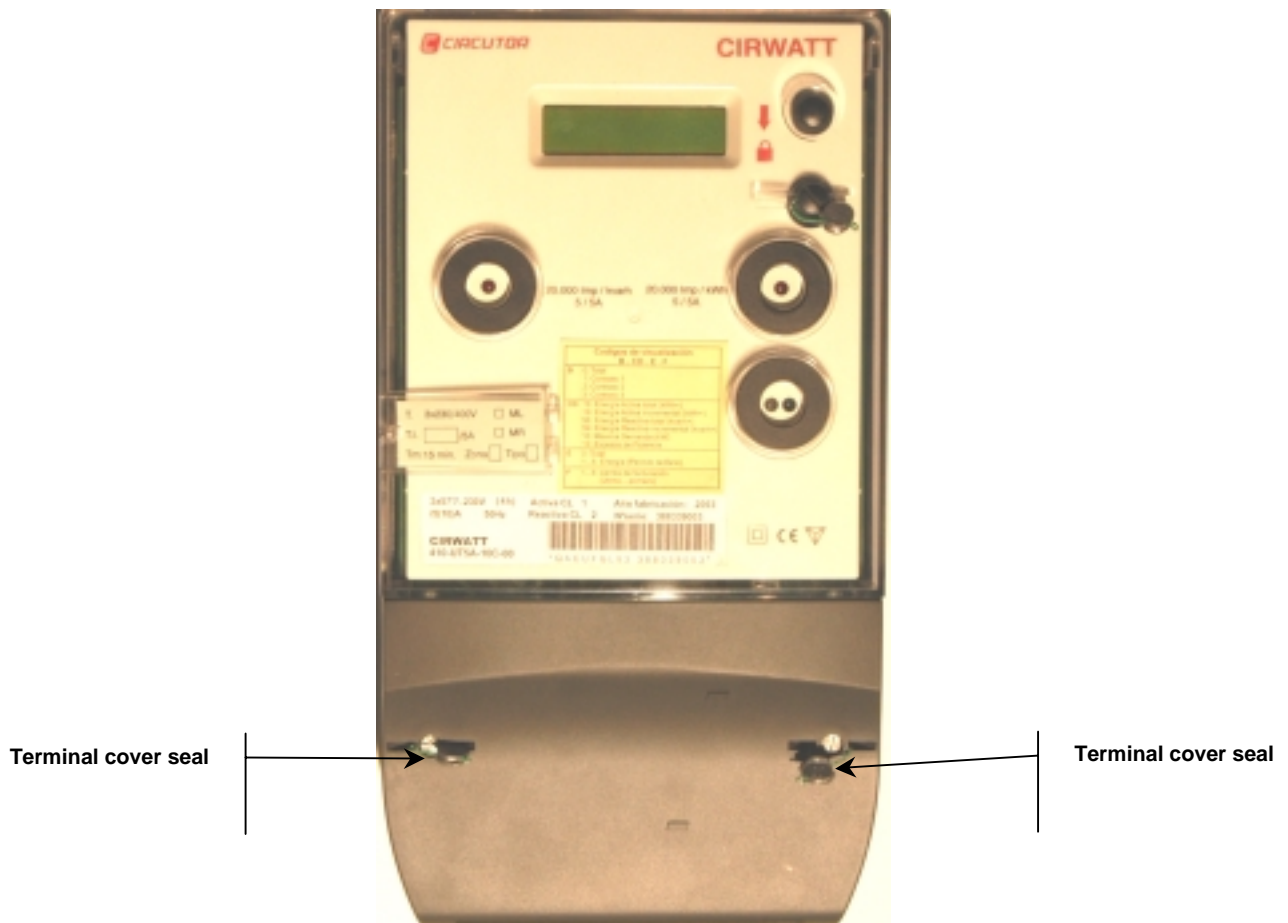

Changing the clock battery is protected by this seal.

3.8.3. Setting, bill closure and meter start up seal.

This seal blocks any setting that may affect the meter recording data, for example: tariff selection, timing calendar configuration, clock setting, recording period to obtain load curve, transformer ratios, etc.

Requested by:	Written by:	
CIRCUTOR, S.A.	Ramón Comellas Fusté Collegiate no.: 5354	

It also blocks bill closures and equipment start up (deleting counters and files).

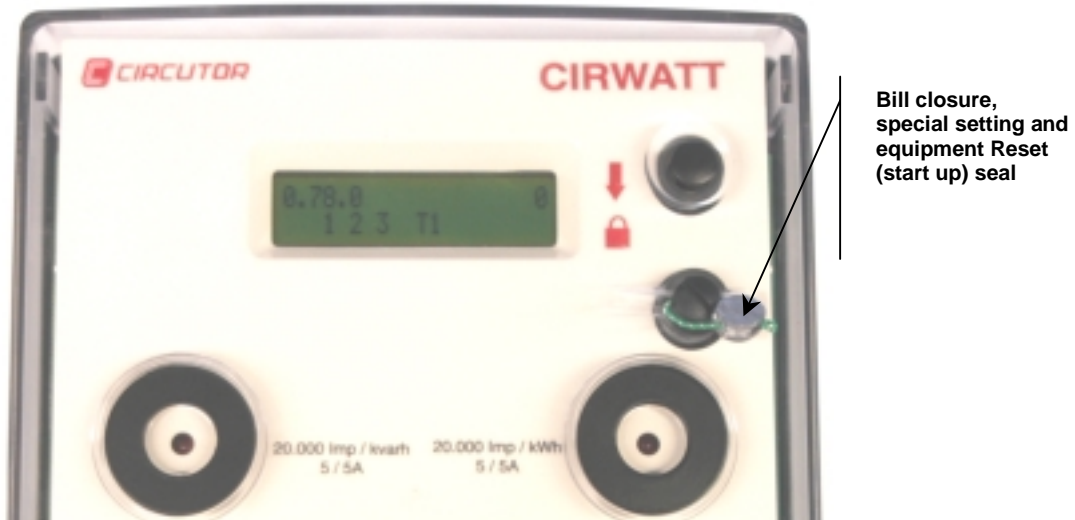

3.8.4. Transformer ratios, integration period, market type and area of installation label seal.

This blocks the alteration of the transformer ratios label attached by the authorised installer.

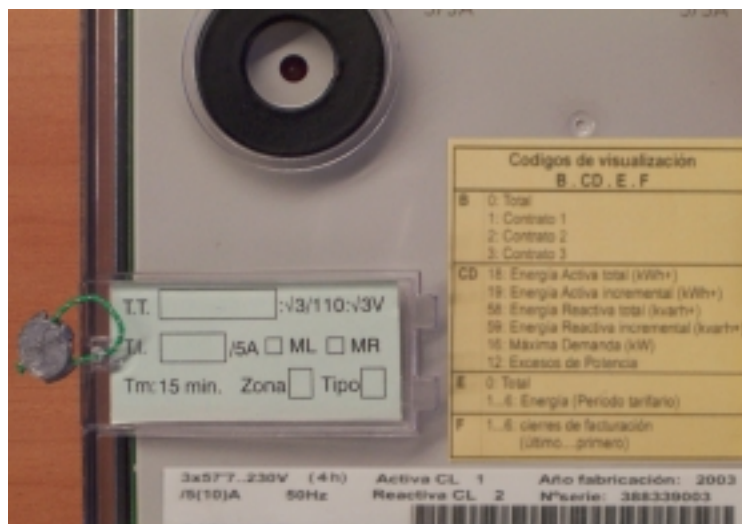

Requested by:	Written by:	
CIRCUTOR, S.A.	Ramón Comellas Fusté Collegiate no.: 5354	

3.8.5. Protection of information stored in the memory.

All communications access to the meter's memory is protected by reading and writing passwords.

These passwords have more than 4000 million combinations, making the meter highly protected against the alteration of recorded information (load curves, events, tariffs, set-up).

Requested by:	Written by:	
CIRCUTOR, S.A.	Ramón Comellas Fusté Collegiate no.: 5354	

4. DESCRIPTION OF THE OPERATION OF THE METER

This section shall describe how the equipment behaves from an operational point of view. That is to say, it shall explain how all the information provided is handled as well as how the different functions of the system are configured.

The description sections will be divided as follows:

- Display system.
- Tariff control system.
- Inputs and outputs.
- Files.
- Keyboard functions.

4.1. DISPLAY SYSTEM

There are two Screen Display modes:

- STANDBY mode.
- READING mode.

STANDBY mode is always the default mode whenever the READING mode is not activated by pressing the corresponding reading button.

READING mode is activated by a long press on the reading button. This mode uses tree structure screens, organised on three hierarchical levels from which information can be accessed.

Once 60 seconds have passed after the last press in READING mode, the display will return to STANDBY mode.

There are three different types of screens:

- Standby screen.
- Menu screen.
- Data screen.

Requested by:	Written by:	
CIRCUTOR, S.A.	Ramón Comellas Fusté Collegiate no.: 5354	

4.1.1. Standby screen.

The standby screen shows information without the need to use the buttons on the equipment. It is used to show the customer the necessary information for him to control measurement in the easiest possible way.

The standby screen is only used in STANDBY mode. All lines of information on this screen are ROTATING. In the event of a serious alarm being shown, the rotation freezes at this line.

In either event the reading buttons can still be used. A short press freezes the rotation and subsequent short presses advance or display different lines on the screen. At the end of 60 seconds it returns to ROTATING mode.

The following information is shown on each line:

- Line 1: Shows in ROTATING mode the **Link direction and the Point of Measurement direction** on the equipment that establishes the IEC-870-5-102-REE protocol for border points (the link direction is shown as 5 digits identified by the code R and the Point of Measurement direction is also shown as a maximum of 5 digits with the code P.); information on the **Current Totals of Active Energy in the two directions and Reactive energy in the four quadrants** (shown by identification code and data in units of kWh or kvarh) and the **Date and Local Time** of the equipment (the format will be day-month-year hour:minute:seconds).

The ROTATING line alternates the information every 6 seconds as set by the UNE-EN 61038 standard on Timing Switches. If there is an alarm, it is shown every two ROTATING screens by the word **FAULT** followed by the letter **N**, **C** or **B** corresponding to the alarm. The display on this type of screen is shown in the diagram below:

```

R.XXXXX P.XXXXX
B-CD.E.FF XXXXXXXX
B-CD.E.FF XXXXXXXX
B-CD.E.FF XXXXXXXX
B-CD.E.FF XXXXXXXX
B-CD.E.FF XXXXXXXX
B-CD.E.FF XXXXXXXX
DD-MM-YYYY HH:MM:SS
    
```

Requested by:	Written by:	
CIRCUTOR, S.A.	Ramón Comellas Fusté Collegiate no.: 5354	

- Line 2: This shows the permanent information on the operating indicators using a line of alphanumeric indicators. The format of the line will be as follows:

Q1 1+2+3+ T123 CNB P

Being:

- Q1 the quadrant (Q1,Q2,Q3,Q4).
- 1+2+3+ the presence of voltage in each phase with its corresponding current direction.
- T123 the tariff periods in operation in the contracts 1, 2 and 3 respectively.
- N non critical alarm.
- C critical alarm.
- B battery alarm.
- P special parameterisation enabled.

The following diagram shows an example of the screen in STANDBY mode. Movement between screens is done automatically every 6 seconds or whenever the non-sealed key is given a short press.

Requested by:	Written by:	
CIRCUTOR, S.A.	Ramón Comellas Fusté Collegiate no.: 5354	

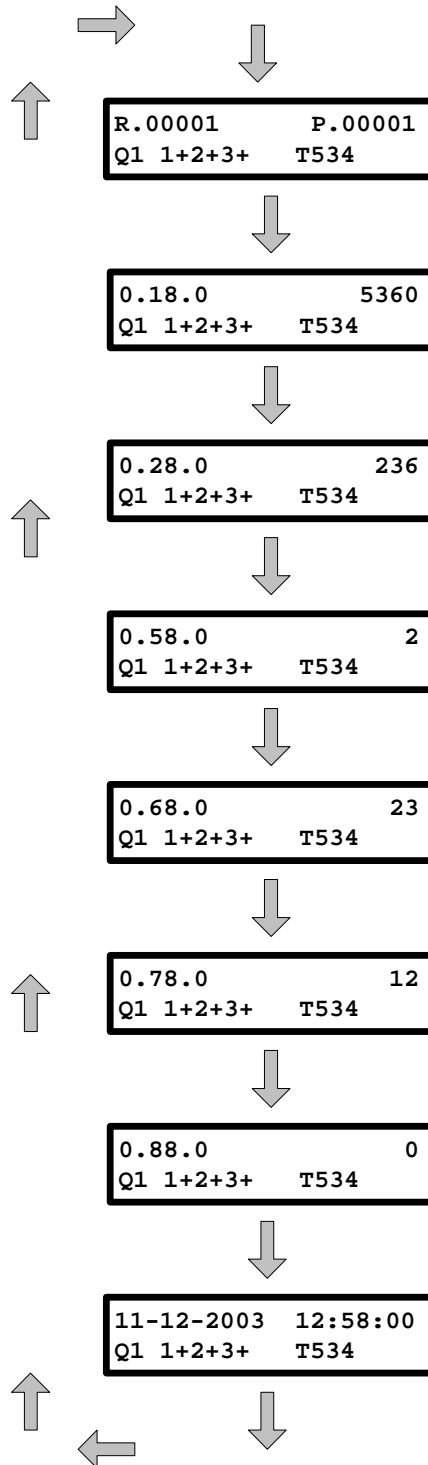

Requested by:	Written by:	
CIRCUTOR, S.A.	Ramón Comellas Fusté Collegiate no.: 5354	

4.1.1.1. Critical and non-critical alarms.

These alarms refer to the operation of the meter and are set off by the meter's internal alarms.

Internal and external events directly affecting measurement set off the critical alarm. Its C symbol flashes.

Events not directly affecting measurements, but showing a meter malfunction, set off the non-critical alarm. The meter has to be replaced as soon as possible. Its N symbol flashes.

The standby values alternate with the alarm display represented by the word "FAULT" followed by the letters N, C, B, if it is a non-critical, critical or battery alarm.

Each one generates an event that is included in the set defined in the protocol.

4.1.1.2. Battery low alarm.

This alarm is goes off when the battery reserves reach 10% of the total. It switches off if the battery reserves are above 50% of the total. The symbol will be an intermittent B. This alarm will also set off a non-critical alarm as indicated in the previous section.

4.1.2. Menu screen.

The Menu screen shows the different options to access the data screen or other secondary menu screens.

It is only used in READING mode.

This screen shows a number of options of which the last one is always the BACK option. This option returns to the screen above. The line being used is shown by the fact that it is flashing.

Browsing the Menu screens is done via the button: a short press advances the cursor to the following line and if it on the last line it advances to the first line. A long press on it will bring up the screen from that option.

Requested by:	Written by:	
CIRCUTOR, S.A.	Ramón Comellas Fusté Collegiate no.: 5354	

4.1.3. Data screen.

The Data screen shows information on a certain group of data. It can only be used in READING mode.

Browsing between Data screens is done using the button: a short press advances the cursor to the following line and if it is on the last screen it advances to the first screen. A long press on any of the screens will return to the screen on the level above.

The data lines have two fields: a code and the data value. Nine characters are reserved for the code field and the remainder for the value field up to the whole 20 characters on the display.

The Code fields are used to identify the data on the Data and Standby screens.

The structure of the data codes on the display are based on the IEC/UNE-EN 62056-61 OBIS standard.

Requested by:	Written by:	
CIRCUTOR, S.A.	Ramón Comellas Fusté Collegiate no.: 5354	

The structure of the fields and separators used, is as follows:

B .	C	D .	E .	F
------------	----------	------------	------------	----------

- The B Values Group has a size of 1 character. It sets the contract to which the data corresponds. It can take values of 0,1, 2 or 3. The 0 value is used for data not associated to any contract.
- The separator that follows the B Values Group is a full stop (.)
- The C Values Group has a size of 1 or 2 characters according to the event. It generally defines the physical or abstract size of the data. It takes the values defined in the IEC standard.
- There is no separator following the C Values Group.
- The D Values Group has a size of 1 or 2 characters according to the event. It defines the type or result of the process if a size defined by group C according to different algorithms. It can have values 0 to 9 defined by the IEC standard.
- The separator that follows the D Values Group is a full stop (.)
- The E Values Group has a size of 1 character. It generally defines the tariff corresponding to the value defined by B, C and D. It can take values 0 to 9 from those defined by the IEC standard.
- The separator that follows the E Values Group is a full stop (.)
- The F Values Group has a size of 2 characters. It defines the number of the billing period, most recent to oldest, of the values defined by B, C, D and E. It takes all values defined in the IEC standard.

The total length of the Code field will not exceed 9 characters, including separators. When the C field takes up more than 1 character, it does not show the F field, because the size of the code will always be less than or equal to 9 characters.

The contract data screens (L1x, L2x, L3x) has an option on the first screen that allows the ABSOLUTE or INCREMENTAL values to be displayed.

If a long press is made on the INCREMENTAL (or ABSOLUTE) option it moves on to show the INCREMENTAL (or ABSOLUTE) data.

Once the option is selected the behaviour of the screen must be the same as in the general case described in this section.

If none of the initial options is selected (ABSOLUTE or INCREMENTAL) a short press will advance it on to the following screen presenting ABSOLUTE data as a default.

Requested by:	Written by:	
CIRCUTOR, S.A.	Ramón Comellas Fusté Collegiate no.: 5354	

4.2. SCREEN DESCRIPTION

4.2.1. Standby mode Screen.

There is only one screen in STANDBY mode and is defined as the STANDBY screen.

4.2.1.1. R screen (STANDBY).

This screen is displayed in STANDBY mode, i.e. the one which the meter display shows by default whilst no action is taken with the buttons to access READING mode.

4.2.2. Reading mode Screen.

These screens are accessed in READING mode, i.e. by using the corresponding action on the equipment's buttons. They are used to obtain all information that the meter can display using a browsing system via hierarchical screen structure. The sequence of the screens is as follows:

Requested by:	Written by:	
CIRCUTOR, S.A.	Ramón Comellas Fusté Collegiate no.: 5354	

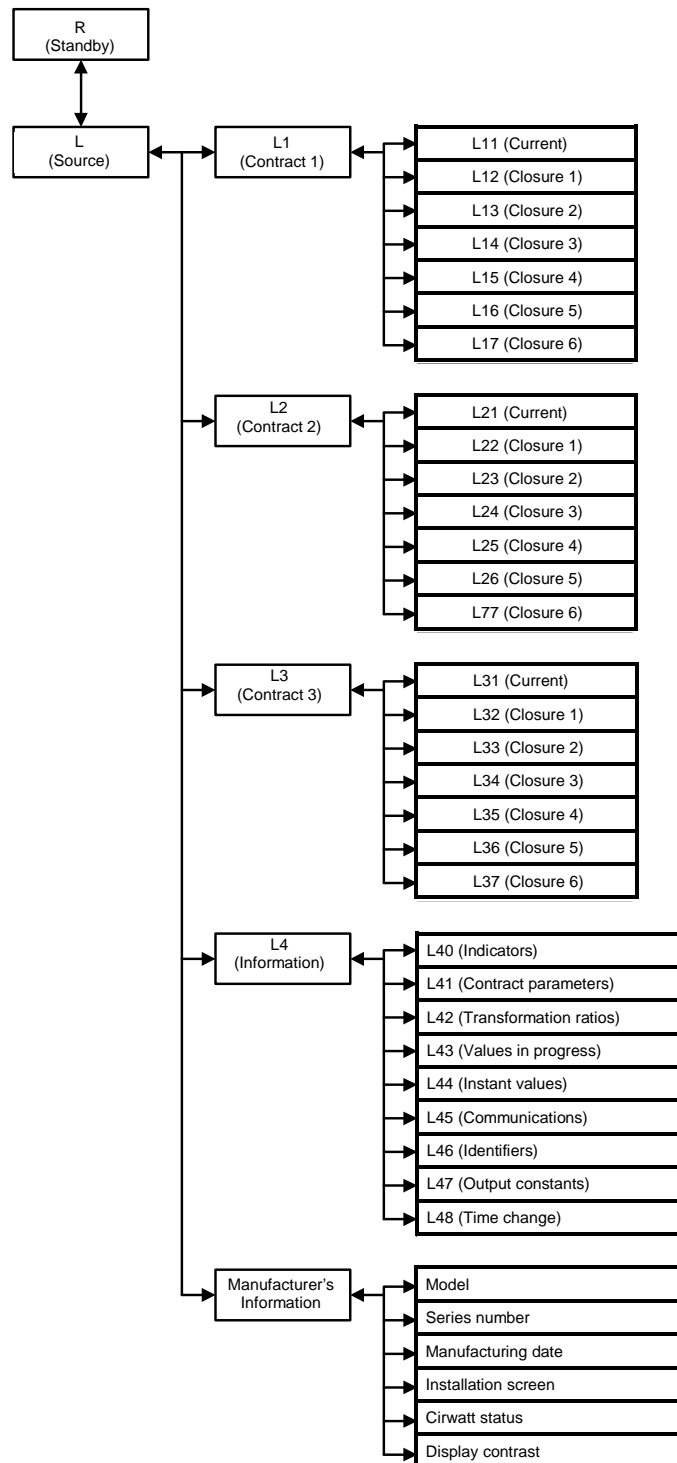

Requested by:	Written by:	
CIRCUTOR, S.A.	Ramón Comellas Fusté Collegiate no.: 5354	

4.2.2.1. L Screen (SOURCE).

This is the first screen accessed in READING mode. It is a MENU screen that accesses other secondary MENU screens.

The options on this screen are:

- CONTRACT 1 accesses data on contract 1.
- CONTRACT 2 accesses data on contract 2.
- CONTRACT 3 accesses data on contract 3.
- INFO: accesses information not related to contracts.
- INFO FAB: accesses extra information defined by the manufacturer.
- BACK: returns to STANDBY screen.

It does not show menu options for contracts that are not defined.

4.2.2.2. CONTRACT 1 screen.

This screen accesses information about contract 1. It is a MENU screen giving access to other secondary MENU screens.

The options on this screen are:

- CURRENT: accesses current values for contract 1.
- CLOSURE 1: accesses contract 1 values for the last closure.
- CLOSURE 2: accesses contract 1 values for the penultimate closure.
- CLOSURE 3: accesses contract 1 values for the antepenultimate closure.
- CLOSURE 4: accesses contract 1 values for the fourth closure.
- CLOSURE 5: accesses contract 1 values for the fifth closure.
- CLOSURE 6: accesses contract 1 values for the sixth closure.
- BACK: returns to the previous screen.

All data screens depending on this screen have the value 1 in group B of the code. They do not display closures that do not exist.

4.2.2.3. CONTRACT 1 screen: CURRENT.

This screen shows information on current Values for contract 1. It is a DATA screen, except for the first display, which is a MENU screen with two options (ABSOLUTE, INCREMENTAL).

Requested by:	Written by:	
CIRCUTOR, S.A.	Ramón Comellas Fusté Collegiate no.: 5354	

This screen only shows information when it is activated, i.e. if certain tariffs or records such as excess or maximum have not been activated, no information about these tariffs or records will appear on the screen.

The ABS (INC) menu option changes the display to Absolute (Incremental). If no option is selected, after a short press the Absolute data is shown by default.

The types of data shown on this screen are shown in order below:

- ABSOLUTE ACTIVE ENERGY: These are identified with the code 1.18.X. Tariff periods for Active Energy from the start of measuring (if active), including the total.
- ABSOLUTE REACTIVE ENERGY: These are identified with the code 1.58.X. Tariff periods for Q1 Reactive Energy from the start of measuring (if active), including the total.
- INCREMENTAL ACTIVE ENERGY: These are identified with the code 1.19.X. Consumption per tariff period for Active Energy from the start of measuring (if active), including the total.
- INCREMENTAL REACTIVE ENERGY: These are identified with the code 1.59.X. Consumption per tariff period for Q1 Reactive Energy from the start of measuring (if active), including the total.
- POWER EXCESSES: These are identified with the code 1.12.X. Excesses from the last bill closure (if active).
- MAXIMUMS: These are identified with the code 1.16.X. Maximums from the last bill closure (if active) including the total.

Data is presented with zeros to the left until the length of the data value field is completed.

4.2.2.4. CONTRACT 1: CLOSURE 01.

This shows information on contract 1 Values from the last closure. The screen behaves in the same way as CONTRACT1: CURRENT.

The type of data shown on this screen is shown below:

- ABSOLUTE ACTIVE ENERGY: These are identified with the code 1.18.X.01. Tariff periods for Active Energy from the start of measuring until the last closure (if active), including the total.
- ABSOLUTE REACTIVE ENERGY: These are identified with the code 1.58.X.01. Tariff periods for Q1 Reactive Energy from the start of measuring until the last closure (if active), including the total.

Requested by:	Written by:	
CIRCUTOR, S.A.	Ramón Comellas Fusté Collegiate no.: 5354	

- INCREMENTAL ACTIVE ENERGY: These are identified with the code 1.19.X.01. Consumption per tariff period for Active Energy for the last billing period (if active), including the total.
- INCREMENTAL REACTIVE ENERGY: These are identified with the code 1.59.X.01. Consumption per tariff period for Q1 Reactive Energy for the last billing period (if active), including the total.
- POWER EXCESSES: These are identified with the code 1.12.X.01. Excesses from the last billing period (if active).
- MAXIMUMS: These are identified with the code 1.16.X.01. Maximums from the last billing period (if active) including the total.

Data is presented with zeros to the left until the length of the data value field is completed.

4.2.2.5. CONTRACT 1 screen: CLOSURE 02.

This shows information on contract 1 Values from the penultimate closure. The screen behaves in the same way as CONTRACT1: CLOSURE 01.

The information is displayed in exactly the same way as on CONTRACT 1: CLOSURE 01, but the Value F Group has the value 02 instead of 01.

4.2.2.6. CONTRACT 1 screen: CLOSURE 03.

This shows information on contract 1 Values from the antepenultimate closure. The screen behaves in the same way as CONTRACT1: CLOSURE 01.

The information is displayed in exactly the same way as on CONTRACT 1: CLOSURE 01, but the Value F Group has the value 03 instead of 01.

4.2.2.7. CONTRACT 1 screen: CLOSURE 04.

This shows information on contract 1 Values from closure 04. The screen behaves in the same way as CONTRACT1: CLOSURE 01.

The information is displayed in exactly the same way as on CONTRACT 1: CLOSURE 01, but the Value F Group has the value 04 instead of 01.

Requested by:	Written by:	
CIRCUTOR, S.A.	Ramón Comellas Fusté Collegiate no.: 5354	

4.2.2.8. CONTRACT 1 screen: CLOSURE 05.

This shows information on contract 1 Values from closure 05. The screen behaves in the same way as CONTRACT1: CLOSURE 01.

The information is displayed in exactly the same way as on CONTRACT 1: CLOSURE 01, but the Value F Group has the value 05 instead of 01.

4.2.2.9. CONTRACT 1 screen: CLOSURE 06.

This shows information on contract 1 Values from closure 06. The screen behaves in the same way as CONTRACT1: CLOSURE 01.

The information is displayed in exactly the same way as on CONTRACT 1: CLOSURE 01, but the Value F Group has the value 06 instead of 01.

4.2.2.10. CONTRACT 2 screen.

This screen accesses information on contract 2. It behaves in exactly the same way as the CONTRACT 1 Screen.

The options on this screen are:

- CURRENT: accesses current values for contract 2.
- CLOSURE 1: accesses contract 2 values for the last closure.
- CLOSURE 2: accesses contract 2 values for the penultimate closure.
- CLOSURE 3: accesses contract 2 values for the antepenultimate closure.
- CLOSURE 4: accesses contract 2 values for the fourth closure.
- CLOSURE 5: accesses contract 2 values for the fifth closure.
- CLOSURE 6: accesses contract 2 values for the sixth closure.
- BACK: returns to the previous screen.

All data screens depending on this screen have the value 2 in group B of the code.

4.2.2.11. CONTRACT 2 screen: CURRENT.

This screen shows current Values from contract 2. It behaves in the same way as the CONTACT 1 screen: CURRENT, but changes the group B code from 1 to 2. The data shown is the same as that shown on the CONTRACT 1 screen: CURRENT, with the exception of Power Excesses, which do not appear.

Requested by:	Written by:	
CIRCUTOR, S.A.	Ramón Comellas Fusté Collegiate no.: 5354	

Data is presented with zeros to the left until the length of the data value field is completed.

4.2.2.12. CONTRACT 2 screen: CLOSURE 01.

This screen shows current Values from contract 2 from the last closure. It behaves in the same way as the CONTACT 1 screen: CLOSURE 1, but changes the group B code from 1 to 2. The data shown is the same as that shown on the CONTRACT 1 screen: CURRENT, with the exception of Power Excesses, which do not appear.

Data is presented with zeros to the left until the length of the data value field is completed.

4.2.2.13. CONTRACT 2 screen: CLOSURES 02 - 06.

This screen shows current Values from contract 2 from the closures prior to the last closures. It behaves in the same way as the CONTACT 1 screen: CLOSURE 02 – CLOSURE 06, but changes the group B code from 1 to 2, and with the exception of Power Excesses which do not appear.

4.2.2.14. L3 Screen (CONTRACT 3).

This screen accesses information on contract 3. It behaves in exactly the same way as the CONTRACT 1 Screen.

The options on this screen are:

- CURRENT: accesses current values for contract 3.
- CLOSURE 1: accesses contract 3 values for the last closure.
- CLOSURE 2: accesses contract 3 values for the penultimate closure.
- CLOSURE 3: accesses contract 3 values for the antepenultimate closure.
- CLOSURE 4: accesses contract 3 values for the fourth closure.
- CLOSURE 5: accesses contract 3 values for the fifth closure.
- CLOSURE 6: accesses contract 3 values for the sixth closure.
- BACK: returns to the previous screen.

All data screens depending on this screen have the value 3 in group B of the code.

4.2.2.15. CONTRACT 3 screen: CURRENT AND CLOSURES 01 - 06.- Importation.

Requested by:	Written by:	
CIRCUTOR, S.A.	Ramón Comellas Fusté Collegiate no.: 5354	

This screen shows current Values from contract 3. It behaves in the same way as the CONTRACT 1 screen: CURRENT, but changes the group B code from 1 to 3 and without showing the power excesses information.

Data is presented with zeros to the left until the length of the data value field is completed.

4.2.2.16. CONTRACT 3 screen: CURRENT AND CLOSURES 01 - 06.- Exportation.

This screen shows current Values from contract 2. It behaves in the same way as the CONTRACT 1 screen: CURRENT, but changes the group B code from 1 to 3 and without showing the power excesses information

As contract 3 is valid for both the purchase and sale of energy, the data codes will depend on which contract is set for which direction of energy. This is applicable for both current values as well as closures.

In the event that contract 3 is set for exportation, the type of data displayed on this screen and their order is the following (for CURRENT data):

- ABSOLUTE ACTIVE ENERGY: These are identified with the code 3.28.X. Tariff periods for Active Energy from the start of measuring (if active), including the total.
- ABSOLUTE REACTIVE ENERGY: These are identified with the code 3.68.X. Tariff periods for Q2 Reactive Energy from the start of measuring (if active), including the total.
- INCREMENTAL ACTIVE ENERGY: These are identified with the code 3.29.X. Consumption per tariff period for Active Energy from the last billing closure (if active), including the total.
- INCREMENTAL REACTIVE ENERGY: These are identified with the code 3.69.X. Consumption per tariff period for Q2 Reactive Energy from the last billing closure (if active), including the total.
- MAXIMUMS: These are identified with the code 3.26.X. Maximums from the last bill closure (if active) including the total.

The remaining closures follow the same structure described above.

Data is presented with zeros to the left until the length of the data value field is completed.

4.2.2.17. Screen L4 (INFORMATION).

Requested by:	Written by:	
CIRCUTOR, S.A.	Ramón Comellas Fusté Collegiate no.: 5354	

This screen accesses information not related to contract billing values. It is a MENU screen giving access to other dependent MENU screens.

The options within this screen are:

- OPERATION INDICATORS.
- CONTRACTED POWERS: access to the parameters for the 3 contracts (contracted powers).
- TRANSFORMATION RATIOS: access to voltage and current transformation ratio values.
- VALUES IN PROGRESS: access to maximum power values in progress, totals and power value from the last integration period.
- INSTANT VALUES: access to instant values of the electrical dimensions.
- COMMUNICATIONS: access to the remote and local communications parameters for the equipment.
- IDENTIFIERS: access to equipment identifiers, including series numbers defined in the IEC-870-5-102 protocol.
- OUTPUT CONSTANTS: access to impulse values for the outputs on the equipment.
- BACK: returns to the previous screen.

4.2.2.18. INFORMATION screen: INDICATORS.

This screen shows information on the operating indicators. It is used to verify the proper working of the equipment in all fundamental areas while it is being installed and on site checks afterwards.

As these indicators do not correspond to any specific contract, but is information general to all, the B field takes the value 0. It is a DATA screen.

Requested by:	Written by:	
CIRCUTOR, S.A.	Ramón Comellas Fusté Collegiate no.: 5354	

The type of data displayed on this screen is described below:

- ACTIVE QUADRANT: This is indicated by the code 0.13.38. It shows the direction of flow of the active and reactive energy or quadrant (1, 2, 3 or 4).
- PRESENCE OF VOLTAGE: This is indicated by the code 0.12.38. It shows the presence of voltage in each phase (123 if there is voltage in all, blank if they do not have voltage).
- CURRENT DIRECTION: This is indicated by the code 0.11.38. It shows the importation direction (+) or exportation direction (-) in each phase (111 if imported, 222 if exported, 000 if there are none).
- ACTIVE TARIFF FOR EACH CONTRACT: This is indicated by the code 0.18.128. It shows the active tariff at the time of reading each contract (contract 1, contract 2, contract 3) (values from 1 to 6 for each contract).
- SETTING MODE: This is indicated by the code 0.96.2.4. It shows if the setting mode is enabled (0 not enabled, 1 enabled).
- ALARMS: This is indicated by the code 0.96.5.0. It shows the alarms defined in the operation specification. The data field will display the letters cnb, which will be activated according to the nature of the alarm.

4.2.2.19. INFORMATION screen: CONTRACT PARAMETERS.

This screen shows information on the contract parameters. It is used to indicate the values of the powers contracted. Given that it is only applied to power excesses in Contract 1, the following example shows only those parameters in the first contract. It is a DATA screen.

The type of data displayed on this screen is described below:

- CONTRACTED POWERS: This is indicated by the code 1.135.X (for contract 1). It corresponds to the values in kW to 2 decimal points of the contracted powers that will be used as excess calculations.

4.2.2.20. INFORMATION screen: TRANSFORMATION RATIOS.

This screen shows information on the transformer ratios. As these indicators do not correspond to any specific contract, but is information general to all, the B field takes the value 0. It is a DATA screen.

The type of data displayed on this screen is described below:

- CURRENT RATIO PRIMARY: This is indicated by the code 0.04.2. It shows the value of the current ratio primary to one decimal point.

Requested by:	Written by:	
CIRCUTOR, S.A.	Ramón Comellas Fusté Collegiate no.: 5354	

- CURRENT RATIO SECONDARY: This is indicated by the code 0.04.5. It shows the value of the current ratio secondary to one decimal point.
- VOLTAGE RATIO PRIMARY: This is indicated by the code 0.04.3. It shows the value of the voltage ratio primary to one decimal point (composite voltage).
- VOLTAGE RATIO SECONDARY: This is indicated by the code 0.04.6. It shows the value of the voltage ratio secondary to one decimal point (composite voltage).

4.2.2.21. INFORMATION screen: VALUES IN PROGRESS.

This screen shows information on values in progress for maximum/total power and power from the last integration period (15 minutes).

As these indicators do not correspond to any specific contract, but is information general to all, the B field takes the value 0. It is a DATA screen.

The type of data displayed on this screen is described below:

- TOTAL A+: This is indicated by the code 0.18.0. Shows the actual total value of the Active Energy consumed.
- TOTAL A-: This is indicated by the code 0.28.0. Shows the actual total value of the Active Energy delivered to the system.
- TOTAL R1: This is indicated by the code 0.58.0. Shows the actual total value of the Reactive Energy in quadrant 1.
- TOTAL R2: This is indicated by the code 0.68.0. Shows the actual total value of the Reactive Energy in quadrant 2.
- TOTAL R3: This is indicated by the code 0.78.0. Shows the actual total value of the Reactive Energy in quadrant 3.
- TOTAL R4: This is indicated by the code 0.88.0. Shows the actual total value of the Reactive Energy in quadrant 4.
- INPUT POWER IN PROGRESS: This is indicated by the code 0.14.0. Shows the value of the average input power being taken in during the current integration period.
- OUTPUT POWER IN PROGRESS: This is indicated by the code 0.24.0. Shows the value of the average output power being taken in during the current integration period
- LAST INPUT PERIOD POWER: This is indicated by the code 0.15.0. Shows the value of the average input power being taken in during the last integration period.
- LAST OUTPUT PERIOD POWER: This is indicated by the code 0.25.0. Shows the value of the average output power being taken in during the last integration period.

Requested by:	Written by:	
CIRCUTOR, S.A.	Ramón Comellas Fusté Collegiate no.: 5354	

4.2.2.22. INFORMATION screen: INSTANT VALUES.

This screen shows instant values of the electrical dimensions.

As these indicators do not correspond to any specific contract, but is information general to all, the B field takes the value 0. It is a DATA screen.

The type of data displayed on this screen is described below:

- VOLTAGES PER PHASE: Showing the instant values for Voltage in each phase. These are indicated by the codes 0.327.0, 0.527.0, 0.727.0.
- CURRENTS PER PHASE: Showing the instant values for Current in each phase. These are indicated by the codes 0.317.0, 0.517.0, 0.717.0.
- COS Φ PER PHASE: Showing the instant values for COS ϕ in each phase. These are indicated by the codes 0.337.0, 0.537.0, 0.737.0.
- INSTANT POWER A: This shows the total value of the instant Active Power in the three phases with their sign. It is indicated by the code 0.17.0.
- INSTANT POWER R: This shows the total value of the instant Reactive Power in the three phases with their sign. It is indicated by the code 0.37.0.
- AVERAGE POWER FACTOR: This shows the value of the instant average Power Factor in the three phases. It is indicated by the code 0.137.0.

4.2.2.23. INFORMATION screen: COMMUNICATIONS.

This screen shows information on the different parameters for the communications ports.

As these indicators do not correspond to any specific contract, but is information general to all, the B field takes the value 0. It is a DATA screen.

The configuration data for the ports are in the following format:

VVVVVV C, where **VVVVVV** indicates the baud speed with six whole digits and **C** is the parity (for example, "019200 n").

The type of data displayed on this screen is described below:

- SERIES OPTICAL PORT CONFIGURATION: This is identified by the code 0.00.0.
- SERIES ELECTRICAL PORT CONFIGURATION 1: This is identified by the code 0.00.1.
- SERIES ELECTRICAL PORT MODEM START UP MODE 1: This is identified by the code 0.00.3.

Requested by:	Written by:	
CIRCUTOR, S.A.	Ramón Comellas Fusté Collegiate no.: 5354	

4.2.2.24. INFORMATION screen: IDENTIFIERS.

This screen shows information on the different equipment identifiers including those concerning the IEC870 protocol.

As these indicators do not correspond to any specific contract, but is information general to all, the B field takes the value 0. It is a DATA screen.

The type of data displayed on this screen is described below:

- LINK DIRECTION: This is identified by the code 0.00.5.
- MEASUREMENT POINT DIRECTION: This is identified by the code 0.00.6.
- DATE OF COMMUNICATIONS VERSION PROTOCOL (dd/mm/yy): This is identified by the code 0.00.7.
- VERSION OF EQUIPMENT'S FIRMWARE: This is identified by the code 0.02.0.
- INTEGRATION PERIOD FOR THE FIRST LOAD CURVE: This is identified by the code 0.08.4.
- INTEGRATION PERIOD FOR THE SECOND LOAD CURVE: This is identified by the code 0.08.5.

4.2.2.25. INFORMATION screen: OUTPUT CONSTANTS.

This screen shows information on the output impulse values. As these indicators do not correspond to any specific contract, but is information general to all, the B field takes the value 0. It is a DATA screen.

The type of data displayed on this screen is described below:

- TYPES OF IMPULSE OUTPUTS AND VALUES: This is identified by the codes: 0.03.3 (output 1), 0.03.4 (output 2), 0.03.5 (output 3), 0.03.6 (output 4). For each output (from 1 to 4) they indicate the type of associated output and the impulse weight.

The options for each type of output are:

- **Ax Y** ($x = 1$: imported active, $x = 2$: exported active; **Y** = impulse weight in decimals of KW).
- **rx Y** (x = quadrant no.: reactive quadrant **x**; **Y** = impulse weight in decimals of KW).
- **Pot** (power demand meter)
- **Cx Py** (x = contract no., y = tariff period no.: tariff output).

Requested by:	Written by:	
CIRCUTOR, S.A.	Ramón Comellas Fusté Collegiate no.: 5354	

When the output is not associated with any type the data shows the word Nil.

For example, “**A1 10**” for active importation, giving one pulse every 0.1Wh; “**r1 100**” for reactive quadrant 1, giving 1 pulse every 1Wh; “**Pot**” for power demand meter, “**C1 P1**” for tariff 1 of contract 1.

4.2.2.26. INFORMATION screen: TIME CHANGE.

This screen shows information on the dates of time changes. As these indicators do not correspond to any specific contract, but is information general to all, the B field takes the value 0. It is a DATA screen.

The type of data displayed on this screen is described below:

- TIME CHANGE WINTER-SUMMER: This is identified by the code 0.00.8. Showing the date and Winter-Summer time change.
- TIME CHANGE SUMMER-WINTER: This is identified by the code 0.00.9. Showing the date and Summer-Winter time change.

4.2.2.27. MANUFACTURER’S INFORMATION screen: MODEL.

The firmware version installed and the meter model appear on this screen.

4.2.2.28. MANUFACTURER’S INFORMATION screen: SERIES NUMBER.

The meter’s series number appears on this screen. It has 9 digits and the first three are always 388 (E.g.: 388XXXXXX).

4.2.2.29. MANUFACTURER’S INFORMATION screen: MANUFACTURING DATE.

This shows the date (day – month – year) when the meter was manufactured.

4.2.2.30. MANUFACTURER’S INFORMATION screen: INSTALLATION SCREEN.

The voltage, current in the 3 phases and the frequency can be seen at the same time on this screen The current measured shows its symbol, something which is very useful when checking if the external connections have been correctly made.

The maximum current that can be shown is 9A. If this current is exceeded the equipment shows the letter ‘O’.

4.2.2.31. MANUFACTURER’S INFORMATION screen: CIRWATT STATUS.

Requested by:	Written by:	
CIRCUTOR, S.A.	Ramón Comellas Fusté Collegiate no.: 5354	

This screen is useful for knowing the status of the meter. The meter continuously checks the vital working parts and displays if there are any errors in any of them.

4.2.2.32. MANUFACTURER'S INFORMATION screen: DISPLAY CONTRAST.

The display contrast can be changed using this screen. The default contrast value setting is 75%, but by pressing the unsealed key, this can be decreased to 5%. Once at this point, if the unsealed key is pressed again the contrast returns to 95%.

The following diagram shows the special manufacturer's menu, showing which keys have to be pressed to access it.

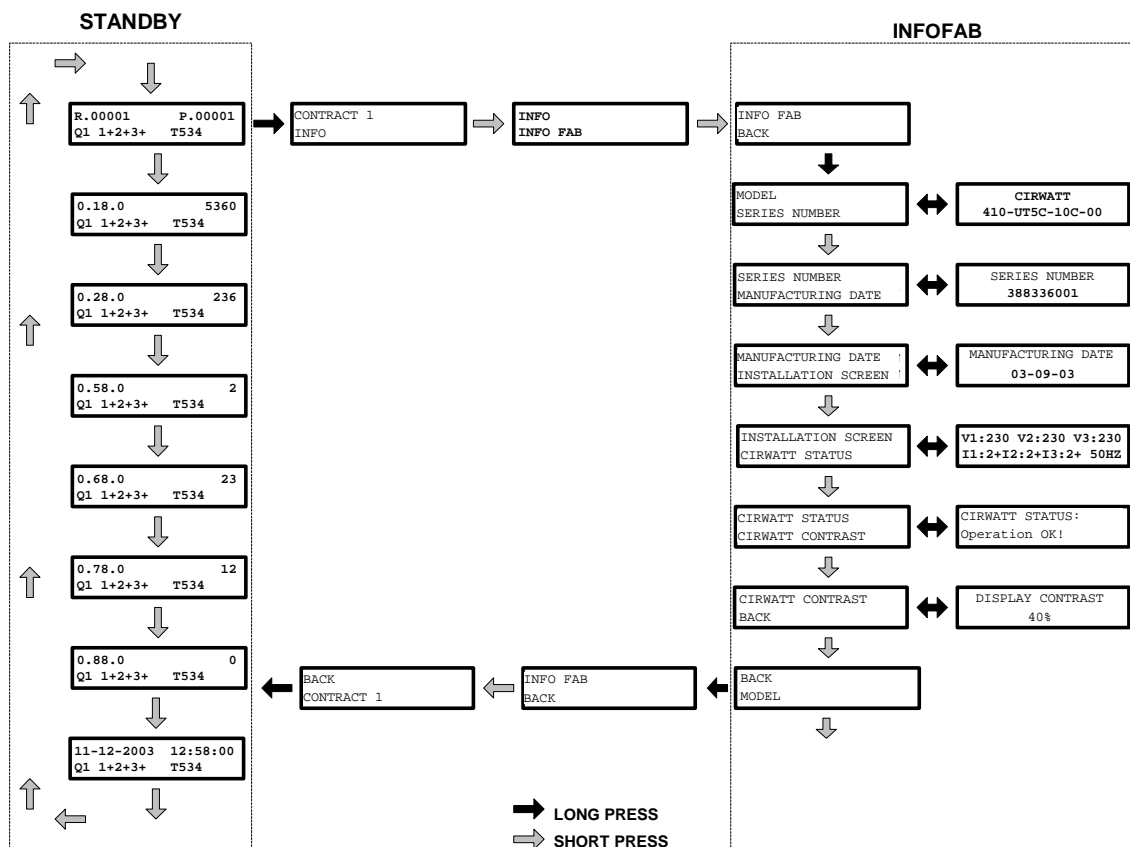

Requested by:	Written by:	
CIRCUTOR, S.A.	Ramón Comellas Fusté Collegiate no.: 5354	

4.3. CONTRACTS IN CIRWATT.

As well as basic measurements, it is necessary that the equipment makes a set of calculations to allow a proper invoicing with the type of contract on it.

It is understood by contract, the set of parameters that structure the measurement made by the logger so as to reflect the contractual billing agreements.

4.3.1. *Number and assignment of contracts.*

Depending on the measuring point type the meter – logger will have 0, 1, 2 or 3 defined contracts.

The Transport / Distribution and Generation / Transport borders do not require the definition of any type of contract.

The remaining borders and customers necessitate the definition of up to three contracts. The first (contract 1) to obtain the necessary data for invoicing the Third Party Access to the System (TAS), the second (contract 2) for the agreement between the Marketer and Customer or regulated market customers and the third (contract 3) for invoicing generators under special circumstances or a second contract between Marketer and Customer.

4.3.2. *Parameters of a contract.*

It is considered that a parameter is defined if it has an assigned value. It is not defined if this is blank.

A parameter that is not used will not be able to have a value assigned from previous parameter settings and therefore will remain undefined.

4.3.2.1. Activation date.

This is the date from which the meter – logger uses the contract parameters to calculate the necessary data for invoicing.

Requested by:	Written by:	
CIRCUTOR, S.A.	Ramón Comellas Fusté Collegiate no.: 5354	

4.3.2.2. Season.

The word Season is given to each period of time into which the natural year can be divided and during which the invoicing conditions associated with it do not vary. The maximum number of seasons is 12.

Two types of seasons are considered:

- Winter / Summer seasons. These form two different seasons during the year and are delineated by the dates of the official time change, without the need for any type of setting. It changes automatically every year.
- Defined seasons. Each season starts on a predetermined date, the end of which is the starting date for the following season in a chronological fashion and not being influenced by the year. Each season is identified by a number starting with 1 and increasing by 1 up to a maximum of 12.

4.3.2.3. Types of days.

The days of the year are classified as:

- Working days.
- Holidays.
- Special days.

Working days are Monday, Tuesday, Wednesday, Thursday and Friday. All have the same tariff rate throughout a season.

Holidays are Saturday and Sunday and other days considered to be holidays. All have the same tariff rate throughout a season.

A special day is one, which is assigned a specific tariff, different to the others. The maximum number of special days is 10.

Special days and holidays other than Saturdays and Sundays are identified by their date and with a format that may contain one offs.

4.3.2.4. Tariff periods. Type of day.

Each hourly block to which a predetermined tariff is applied is called a tariff period. In the regulated market and for TAS they are defined each year by the administrator. Others types may exist apart from these, after agreement between the Customer and Marketer. There will be a minimum of one hourly block and a maximum of nine. Each period is identified by a number starting at one and increasing.

Requested by:	Written by:	
CIRCUTOR, S.A.	Ramón Comellas Fusté Collegiate no.: 5354	

Type of day is assigned to the set of tariff periods given to each of the 24 hours in the day.

Each type of day is identified by a number starting at 1 and increasing by one for successive types.

Working days and holidays have an associated type of day for each season. Each special day has one type of day associated with it.

4.3.2.5. Powers.

Each tariff period has a power associated with it corresponding to the value of the contracted power in each period. This is the calculation basis for invoicing excess power required from the system.

In the event that this parameter is not defined for any tariff period, it will mean that there is no contracted power per period to perform the excess calculations. If the power is defined in only one period, the remaining periods not being defined, it will be assumed that they have a zero power defined and excess calculations will be made for all periods.

4.3.2.6. Bill closures.

Bill closure is considered to be the storage in the memory of the following values at a predetermined time:

- Values showing energy totals at a predetermined time (absolute reading).
- Values of the energy measured from the previous closure or from the meter start up, if it is the first closure (incremental reading).

Measurements and calculations stored are:

- Absolute and incremental active energy values.
- Absolute and incremental inductive and capacitive reactive energy values.
- Average active power calculated every 15 minutes maximum.
- Power excesses calculations.

Closures are made on total measurements and on all tariff periods of active contracts.

Each closure has the date and time when it was made.

Requested by:	Written by:	
CIRCUTOR, S.A.	Ramón Comellas Fusté Collegiate no.: 5354	

A minimum time in minutes has to pass between consecutive closures. This time can be set and will be 10 minutes as a default setting.

The meter – logger keeps an historical record of the last 64 closures (if only one contract is active). These are performed and chronologically ordered from most recent to oldest. If three contracts are active, the maximum number of closures that can be stored is 21.

The types of closure are:

- Immediate closure. This may be done at any time by a manual command from the button or communications message. The power values are taken as up to the end of the integration period 15 minutes immediately prior to the command. Closure by button affects all active contracts, closure by communications message may affect one or more of the active contracts.
- Automatic closure. These are programmable parameters showing the date when the automatic closure of each contract was made. The date may contain one offs during the month and year. This type of closure may affect one or more of the active contracts.

An extra-ordinary closure is done in the following circumstances:

- Change of transformer ratio affecting all contracts.
- Change of contracted power per period, affecting the contract modified.
- Change of season or type of day, affecting the contract modified.

4.3.3. Maximums.

The highest average value of active power demanded during a 15 minute period in the time between two consecutive bill closures, is called the maximum.

These 15 minute periods will coincide with the integration periods of the 15 minute load curve, i.e. in each hour they will start on 0, 15, 30 and 45 minutes and ending with the start of the following period.

Maximums are associated to each tariff period that they define and to the whole set. Each value are identified by the date, hour and minute in which they happened.

15 minute periods where there has been time checking, a power cut or reconnection, or where something invalid has occurred (change of parameter or intrusion), will not be taken into account for the purposes of maximums calculations.

Requested by:	Written by:	
CIRCUTOR, S.A.	Ramón Comellas Fusté Collegiate no.: 5354	

4.3.4. Defined, active and latent contracts.

A contract is said to be defined when at least the seasons and types of day have been defined.

A defined contract is active when it is being used to calculate the requirements for invoicing.

Each contract has a latent contract associated with it. This is to allow the parameters of the active contract to be changed on a date prior to it becoming valid.

A contract changes from latent to active when the activation date is reached, even when the equipment is not connected to a power supply or when the equipment starts up after being reconnected.

When the activation date of a latent contract is reached, the logger has to automatically perform an immediate and extra-ordinary bill closure on the affected contract. The parameters set for the latent contract become undefined. This way the latent contract is removed from that point.

In the event that there is no active contract and other different contracts are set and activated, the recorded information at the time of activation will not be altered and data for all active contracts will be displayed.

4.3.5. Modification of contracts.

A contract is said to be modified if any previously set contract parameter is reset, altered or deleted.

The modification may affect an active or latent contract.

Although the parameters of a contract form part of a single set, partial or one off modifications may be made to groups of parameters. these groups are determined by their coherency between each other.

In the event of modifying a group of powers, it will also be necessary to change the group of seasons and types of day beforehand in order to maintain coherency. The groups are:

- Holidays (up to 30).
- Powers.

Requested by:	Written by:	
CIRCUTOR, S.A.	Ramón Comellas Fusté Collegiate no.: 5354	

- Automatic bill closure date.
- Seasons (12) and types of day (10).

Modification is done by whole groups by deleting existing parameters and replacing them with those defining the modification.

Modification of the Power and Seasons groups and types of day generate an automatic bill closure before the change is implemented. When the two groups are modified in one single process, only one bill closure is created. The remaining groups are implemented immediately and do not generate a bill closure.

If the modification entails a reduction in invoicing periods, the meter – logger will behave as follows when the bill closure is activated and performed:

- Records of the closures performed at that time are stored in the memory and may be displayed.
- The overall total and those totals for the remaining period are stored. From then on, the overall total and the totals for the periods still remaining with the new setting are displayed and continue to increase. The deleted totals are no longer stored and displayed.

If contract modifications that entail invoicing periods to be lengthened are made, there is a bill closure at the time of activation. The information recorded up to then and all totals are stored. Totals for new periods start from zero and those already existing increase from the previous value.

4.3.5.1. Modification of an active contract.

Modification to an active contract may affect one or more parameter groups and may be done immediately. An automatic bill closure on the affected contract may occur prior to the change depending on the parameters.

4.3.5.2. Modification of a latent contract.

Modification to a latent contract may affect one or more parameter groups and does not generate an automatic closure.

If the activation date is before the current date it will act as a modification of an active contract and will not take into consideration that activation date.

If a modification is made with an activation date different to the already existing date and before the current date, the new activation date is considered to be the date of the last modification received.

Requested by:	Written by:	
CIRCUTOR, S.A.	Ramón Comellas Fusté Collegiate no.: 5354	

4.3.6. Deleting contracts.

Deleting a contract is undefining all those parameters that have been defined and the related data not being displayed.

If more than one contract have been defined, are active and one of them is deleted leaving the remainder, then a bill closure is done at the time of deletion. From then on information on this contract is deleted and no longer displayed, except that information referring to bill closures that may exist. The remaining contracts and corresponding totals are not modified.

4.3.7. Returning a meter – logger to zero.

All set parameters and stored data are deleted. Totals go back to zero. The date and time, the battery status and the manufacturer set parameters remain.

The default parameters included are the following:

Link direction	1
Measurement point direction	1
Passwords	1
Speed at all ports	9600 bauds
Configuration of all ports	8N1
Seasonal change	Automatic

This operation is always done on site and is protected by the password and seal and generates an event.

Requested by:	Written by:	
CIRCUTOR, S.A.	Ramón Comellas Fusté Collegiate no.: 5354	

4.4. INPUTS AND OUTPUTS

The equipment has an optional expansion card for inputs and outputs. The functions of this card can be configured.

4.4.1. Digital outputs.

Digital outputs are those parts that can externally transmit electrical signals from the meter – logger using a free of potential contact. This type of output is optional. They come in two types:

- **Measured energy impulses**
 - Sends active energy impulses taken from the system.
 - Sends active energy impulses given to the system.
 - Sends reactive energy impulses taken from the system.
 - Sends reactive energy impulses given to the system.
- **Signalling and control impulses**
 - Power demand meter impulse.
 - Tariff period indicator (from 1 to 9)

All existing outputs are numbered from 1 upwards.

Each one can be assigned a configuration for any function, with no restrictions. The weight of the impulse can also be set for energy impulses.

4.4.2. Digital inputs.

Digital inputs can be configured to perform the following functions:

- **Setting tariffs:** Each input can be programmed to externally show the equipment the active tariff. In the event of being the tariff system being configured by using the internal clock, the value of the tariff shown by the inputs will have priority. It will also be possible to select if the tariff value is given by the binary combination or direct from the inputs.
- **Synchronising the power demand meter:** It is possible to show the integration period of the power demand meter by using an external input. As previously stated it can operate together with the internal system linked to the clock with the external system. However the latter will always have priority.

Requested by:	Written by:	
CIRCUTOR, S.A.	Ramón Comellas Fusté Collegiate no.: 5354	

- **Bill closure:** Finally the input may be programmed so that it produces a bill closure when it detects a pulse to do so. All possible closure systems have the same priority and operate with the same safety timings.

Requested by:	Written by:	
CIRCUTOR, S.A.	Ramón Comellas Fusté Collegiate no.: 5354	

4.5. FILES

Data is organised into three types of file. Each one has an area of this memory reserved for it, so that each of these memory areas can only be used to store data for that file:

- **Load profile records:** Energy consumption is periodically recorded.
- **Tariff records:** When a bill closure is made, all tariffs are recorded from the meter readings. These records are only made from energy consumed (2 quadrants).
- **Event register:** All dates of the set-up modifications, battery changes, time changes, bill closures etc are recorded.

Type		Record size	Nº of Records	Time
Events		12 bytes	>512	
Tariff		1024 bytes	64	> 5 years (1 contract)
Load profiles	Programmable 1	64 bytes	5120	> 213 days (with hourly integration period)
	Programmable 2	64 bytes	5120	> 50 days (with quarter hourly integration period)

Data in each of the files is organised on a rotating basis. This means that once the memory is full, new data is stored instead of the oldest data. This system ensures that the meter always has updated information and has the most recent data obtained.

Requested by:	Written by:	
CIRCUTOR, S.A.	Ramón Comellas Fusté Collegiate no.: 5354	

4.6. FUNCTIONS OF THE KEYBOARD

The functions of the keyboard are defined below. It is based on a single key and a long press/short press system. A short press is one lasting less than 2 seconds. On the other hand a long press is one that lasts longer than 2 seconds.

4.6.1. Unsealed key.

In ROTATING mode a short press will freeze the rotation. The following short presses will move forward or display the different lines on the screen. On the other hand a long press moves it on to the (flashing) menu option displayed on the screen.

4.6.2. Sealed key.

This key allows the billing to be manually closed, place the meter in special writing mode and resets it.

Requested by:	Written by:	
CIRCUTOR, S.A.	Ramón Comellas Fusté Collegiate no.: 5354	

4.7. LOAD CURVES

The logger as two incremental load curves, which comply with the specifications in the Royal decree 2018/1997 and its Associated technical Instructions. Both load curves store records with the number of sizes required by the regulation. The depth of recording in both cases is 5120 and the integration period is completely configurable by the user.

In the event of voltage faults, or the clock going forward, the dips in the load curve are made up of invalid zeros.

A load curve incremental value that does not completely correspond to the time in which it is included, is marked as invalid. For example, if it is a value for consumption over several hours.

If load curves are requested in sizes that the equipment does not have recorded, it will answer the request with the sizes it has recorded and will send as zero or invalid those that it does not have recorded.

In both cases the resolution is in 8 digits for energy values measured in kWh or kvarh.

Requested by:	Written by:	
CIRCUTOR, S.A.	Ramón Comellas Fusté Collegiate no.: 5354	

4.8. OFFICIAL TIME CHANGE

The meter – logger will automatically change the official time. In the event that the equipment is not receiving any power at that time, the change will be made on restarting the equipment and restoring the power supply.

The parameters defining this change have two different formats, one of which is generic allowing annual automatic up dates and the other which includes parameters specifically from a communications protocol message. The formats are:

- Generic format independent from the year, with month, day, hour, pre-set back or forward, according to the rules in force (last Sunday in March, etc.).
- Format that specifies year, month, day, time, back or forward.

The parameters for the official time change are automatically updated at the start of the year according to the generic format and independently from the format in which it is programmed. In the event of receiving an established message in the communications protocol to update the official time change, the format is modified according to the message.

Requested by:	Written by:	
CIRCUTOR, S.A.	Ramón Comellas Fusté Collegiate no.: 5354	

4.9. MEASUREMENT VALIDATION CRITERIA

Energy, power demand meter and excesses records will be invalidated when a series of events occur that creates false values. In the specific case of load curves, there is an invalid bit (IV) indicating that this record is not valid. Events that generate invalid measurements are described in the sections below.

4.9.1. *Setting the clock with > T1 = 30 seconds deviation.*

During the fifteen minute period when the setting occurred will not be taken into account in calculating powers.

4.9.2. *Setting the clock with > T10 minutes deviation.*

This invalidates the measurement, i.e. IV qualifier = 1.

4.9.3. *Communications fault between meter and logger.*

If the communications fault coincides with the fifteen-minute period changeover and it lasts for more than 30 seconds, the affected periods will not be taken into account in calculating powers.

If the communications fault coincides with the hourly period changeover and it lasts for more than 10 minutes, the affected periods will be invalidated, i.e. the IV qualifier = 1.

4.9.4. *No power supply in at least one phase.*

This invalidates the measurement for the period in which the fault occurred, IV = 1.

Requested by:	Written by:	
CIRCUTOR, S.A.	Ramón Comellas Fusté Collegiate no.: 5354	

5. VERIFICATION (IMPULSE LEDS)

On the front of the meter there are two LEDs use to give impulses proportional to the consumed and generated active and reactive energy, thereby verifying the measurement.

These LEDs have a fixed cadence printed on the features label on the meter.

Its maximum value is 20,000 pulses (1,000 for the direct meter) for kWh and for kvarh, for measuring active and reactive energy respectively. This pulse ratio is connected to the voltage and nominal current of the meter.

To verify the meter, a minimum time has been defined determined by the following pulse that arrives after a minimum of 120 seconds from the start of verification.

Verification must always start and finish when an impulse arrives.

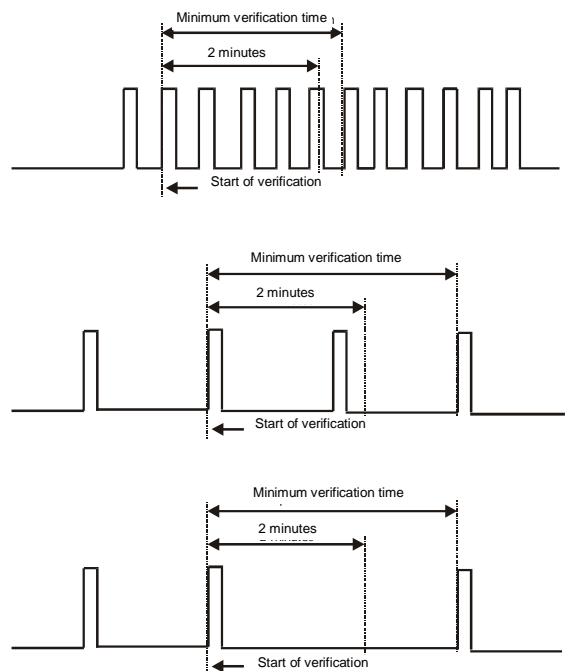

Requested by:	Written by:	
CIRCUTOR, S.A.	Ramón Comellas Fusté Collegiate no.: 5354	

6. COMMUNICATIONS

The equipment has two communications channels:

- **Optical interface:** Complying with the electrical and mechanical specifications in the IEC 61107 standard.
- **RS-232 or RS-485:** Allowing direct communication or via telephone modem for remote communication.

The communications protocol for both ports are:

- **IEC 870-5-102**
- **IEC 61107**

Requested by:	Written by:	
CIRCUTOR, S.A.	Ramón Comellas Fusté Collegiate no.: 5354	

7. REAL TIME CLOCK

By using this clock, the official date and time of the recordings are obtained. It also handles time and period changes.

The real time clock may be set by quartz or the electrical system. In both cases, the clock is accurate to less than 0.5 seconds per day at 25 °C.

When there is no power supply, the clock works off a lithium battery.

It also has a capacitor that can keep the RAM and real time clock supplied with voltage, allowing the battery to be changed without affecting the workings of the meter.

Requested by:	Written by:	
CIRCUTOR, S.A.	Ramón Comellas Fusté Collegiate no.: 5354	

8. LITHIUM BATTERY

The lithium battery that keeps the real time clock and the equipment's RAM working, ensures a 50% charge for 10 years under normal operating conditions.

If the meter suffers long periods of storage or extreme environmental conditions, the battery life will be changed.

The battery is located on the front of the equipment, protected by the terminal cover. Changing it is an event that is recorded in the corresponding file.

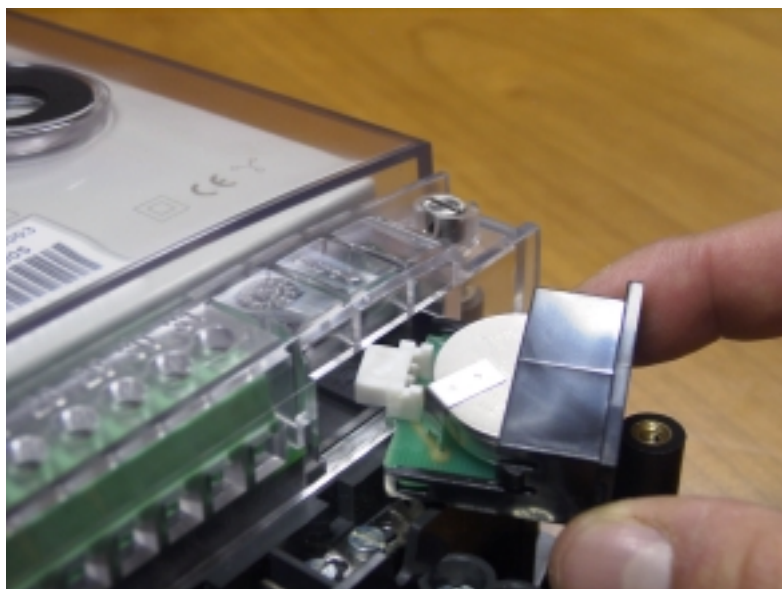

It is noted that the battery can be replaced with the meter receiving voltage, because there is no contact at any time with dangerous voltages.

The equipment also has a capacitor to supply the necessary energy to keep information during the first 96 hours without power supply and allows the battery to be changed without the clock having to be reset.

Requested by:	Written by:	
CIRCUTOR, S.A.	Ramón Comellas Fusté Collegiate no.: 5354	

9. TECHNICAL FEATURES

The CIRWATT electrical and mechanical design has incorporated all of the standards applicable to electronic meters. It also has included operational details (handling and maintenance).

Power Supply:	Self-supplied
Nominal Voltage:	3x57,7/100 V ... 3x230/400V +/- 20%
Consumption:	< 2W y <10VA
Frequency:	50/60Hz no difference
Operating temperature:	-20 °C to + 60 °C
Voltage Measured:	
Voltage:	Multi-range: 3x57.7/100 V ... 3x230/400V
Other voltages:	Via transformers
Frequency:	Automatic (50/60Hz no difference)
Current Measured:	
Currents:	10 A Direct (Max. 100A) Via current transformers (/5A or /1A)
Maximum current:	2·In (indirect) and 10·In (direct)
Accuracy:	
Active Energy:	Class 0.5S and 1.0 Class 1.0 and 2.0
Reactive Energy:	
Calculations and Process:	
Micro-processor:	16 bits - 20 MHz
Converter:	16 bits
Data Memory:	
Type:	FLASH (No battery required)
Configuration:	Rotating
File size:	- Events: 8 Kbytes - Tariffs: 64 Kbytes - Programmable load curve 1: 327 Kbytes - Programmable load curve 2: 327 Kbytes
Independent operating life:	Events: > 512 Tariffs: 64 closures (21 per contract) Load curve 1 (15 Minutes): > 50 days Load curve 2 (Hourly): > 213 days

Requested by:	Written by:	
CIRCUTOR, S.A.	Ramón Comellas Fusté Collegiate no.: 5354	

Battery:	
Type:	Lithium
Life:	50% of its capacity after 10 years
Battery changing time:	Maximum 96 hours without power supply
Clock:	
Type:	Quartz oscillator System frequency
Accuracy:	< 0.5 seconds/day at 25 °C
Digital Inputs:	Free of potential: 60-300 V AC.
Digital Outputs:	Free of potential
Type:	Mechanical, optoMOS or opto-coupling (24V) (according to model)
LED output:	
Maximum cadence:	20000 pulses / kW.h or kvar.h (indirect measurement) 1000 pulses / kW.h or kvar.h (direct measurement)
Safety:	Category III (110 V) according to EN-61010
Construction features:	
Casing:	According to DIN 43859 standard
Sizes:	According to DIN 43857 standard

Requested by:	Written by:	
CIRCUTOR, S.A.	Ramón Comellas Fusté Collegiate no.: 5354	

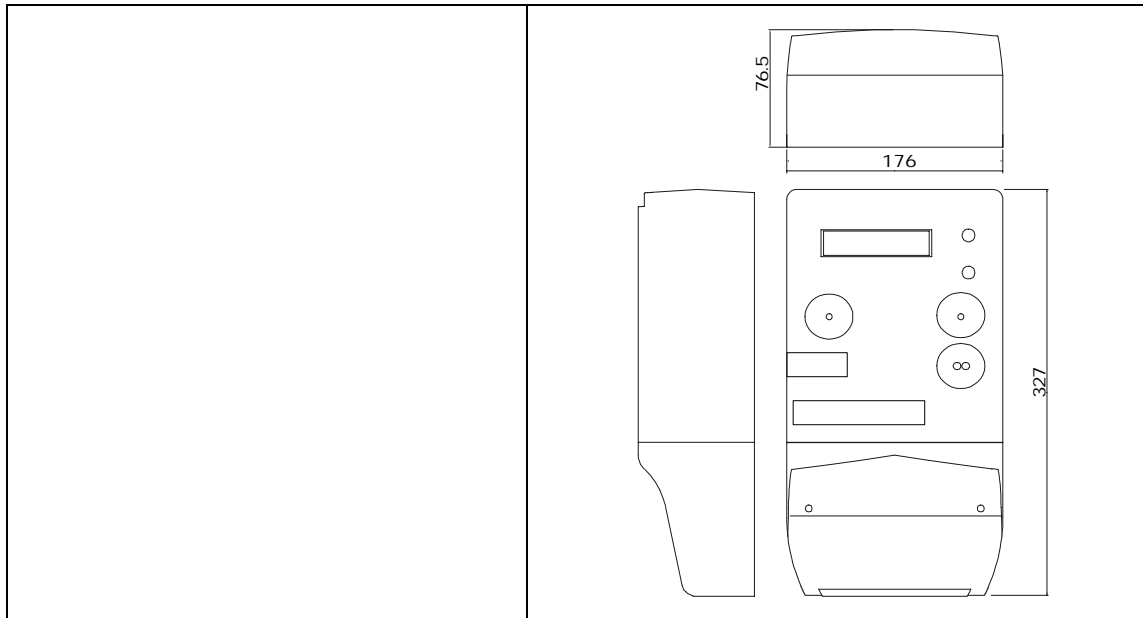

Optical Reader:	IEC-1107 for on-site access
Series Port:	RS-232 or RS-485 CHANNEL
Tests Standards:	
EN 60687 EN 61036 EN 61268	Standards for static, active energy meters for alternating current, class 0.5S and 1.0. Standards for static, reactive energy meters for alternating current, class 0.5S and 1.0.
EN 55022	- Conducted emissions: Class B - Radiated emissions: Class B
EN 61000-4-6	- Immunity to RF fields coupled to cables (common mode): 10 V
EN 61000-4-8	- Immunity to magnetic fields at system frequency: 30 A/m

Requested by:	Written by:	
CIRCUTOR, S.A.	Ramón Comellas Fusté Collegiate no.: 5354	

10. INSTALLATION AND START UP

10.1. INSTALLING THE EQUIPMENT

The meter has been designed to comply with the DIN 43857 standard defining the size and fixing points.

It must be remembered that all connections must remain under the terminal cover.



Remember that when the equipment is connected, the terminals may be dangerous if touched. Opening the covers or removing parts may access parts, which are dangerous when touched. The equipment must not be used until it is finally installed.

Requested by:	Written by:	
CIRCUTOR, S.A.	Ramón Comellas Fusté Collegiate no.: 5354	

10.2. INDIRECT METER TERMINAL RATIOS (SEE LABEL ON TERMINAL COVER)

	<p>No. Terminal description</p> <p><u>Lower Board</u></p> <p>1 Current input IL1 – S1 2 Measurement UL1 3 Current output IL1 – S2 4 Current input IL2 – S1 5 Measurement UL2 6 Current output IL2 – S2 7 Current input IL3 – S1 8 Measurement UL3 9 Current output IL3 – S2 11 Neutral Measurement</p> <p>R1 RS-232 or RS-485 communications</p> <p><u>Upper Board</u></p> <p>21 Relay Output 1 22 Relay Output 1 23 Relay Output 2 24 Relay Output 2 25 Relay Output 3 26 Relay Output 3 27 Contact input 1 28 Contact input 2 29 Contact input 3 30 Contact input 4 31 Common contact input</p>
--	---

NB: The /5A or /1A current inputs are isolated

Requested by:	Written by:	
CIRCUTOR, S.A.	Ramón Comellas Fusté Collegiate no.: 5354	

10.3. INDIRECT METER TERMINAL RATIOS (SEE LABEL ON TERMINAL COVER)

	<p>No. Terminal description</p> <p><u>Lower Board</u></p> <p>1 Current input IL1 – S1 2 Measurement UL1 3 Current output IL1 – S2 4 Current input IL2 – S1 5 Measurement UL2 6 Current output IL2 – S2 7 Current input IL3 – S1 8 Measurement UL3 9 Current output IL3 – S2 10 Neutral connection S1 11 Neutral 12 Neutral connection S2</p> <p>R1 RS-232 or RS-485 communications</p> <p><u>Upper Board</u></p> <p>21 Relay Output 1 22 Relay Output 1 23 Relay Output 2 24 Relay Output 2 25 Relay Output 3 26 Relay Output 3 27 Contact Input 1 28 Contact Input 2 29 Contact Input 3 30 Contact Input 4 31 Common contact input</p>

NB: The current inputs are isolated

Requested by:	Written by:	
CIRCUTOR, S.A.	Ramón Comellas Fusté Collegiate no.: 5354	

10.4. METER CONNECTION DIAGRAM

All CIRWATT models are designed to be connected with 4 wires, but will keep operating and maintain its class with a 3 wire connection.

The required connections are shown in the diagram on the inside of the terminal cover

10.4.1. 4 wire connection, indirect model.

Connecting the current stage is always done via a /5 or /1 transformer according to model. The voltage measurement connection may be direct or via a transformer according to the system voltage.

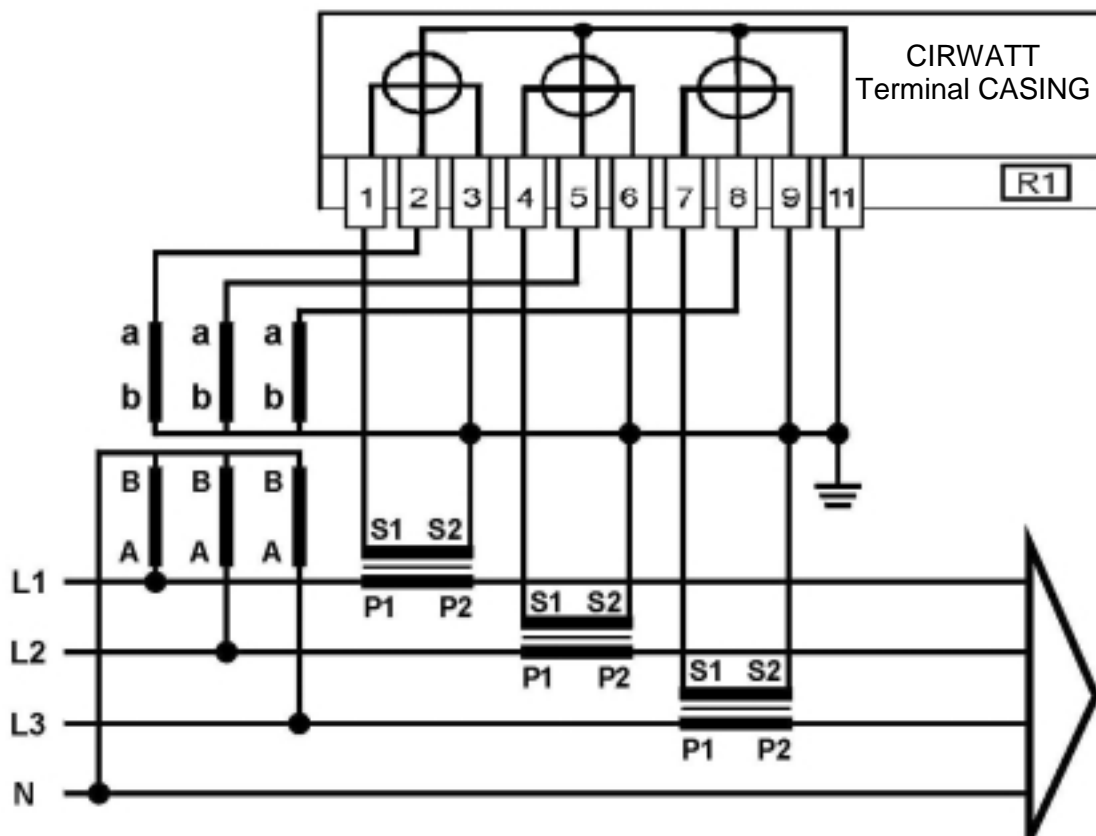

Requested by:	Written by:	
CIRCUTOR, S.A.	Ramón Comellas Fusté Collegiate no.: 5354	

10.4.2. 4 wire connection direct model.

Both the current and voltage measurement are done without the need for external transformers.

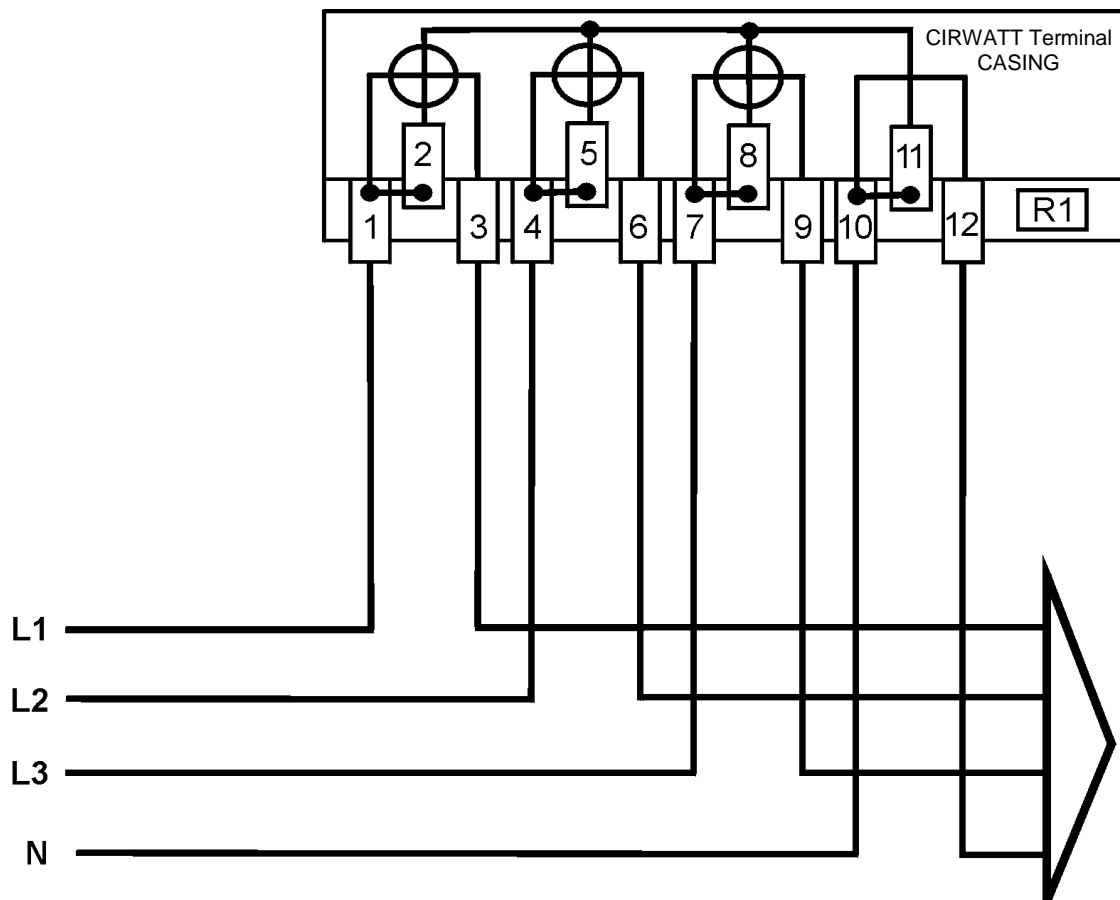

Requested by:	Written by:	
CIRCUTOR, S.A.	Ramón Comellas Fusté Collegiate no.: 5354	

11. MECHANICAL PLANS

Requested by:	Written by:	
CIRCUTOR, S.A.	Ramón Comellas Fusté Collegiate no.: 5354	

12. REPORTS ON TESTS MADE

Requested by:	Written by:	
CIRCUTOR, S.A.	Ramón Comellas Fusté Collegiate no.: 5354	