



**MULTI-PURPOSE
THREE PHASE METER**

**CIRWATT Series
(Version 3.xx)**

**Installation Manual
(M98165601-03 / 04A)**

(c) CIRCUTOR S.A.

INSTALLATION MANUAL	TABLE OF CONTENTS	PAGE No.
1.- INTRODUCTION		2
2.- METER MODELS		2
3.- SAFETY LEVELS (Seals)		0
4.- DISPLAY		3
4.1.- Display Modes		4
4.1.1.- STAND BY Mode		4
4.1.2.- READING Mode		4
4.2.- Types of screen		5
4.2.1.- Stand by screen		5
4.2.2.- Menu Screen		5
4.2.3.- Data Screen		5
4.3.- STAND BY Mode screen		6
4.4.- READING screens mode		7
4.4.1.1.- Screen L1 (CONTRACT 1)		8
4.4.1.2.- Screen L2 (CONTRACT 2)		12
4.4.1.3.- Screen L3 (CONTRACT 3)		12
4.4.1.4.- Screen L4 (INFORMATION)		14
4.4.1.5.- Screen L5 (INFO FAB)		18
5.- TECHNICAL FEATURES		19
6.- INSTALLATION AND START-UP		21
6.1.- Installing the equipment		21
6.2.- Meter terminals ratio (see label on terminal cover)		21
6.3.- Meter connection diagrams		22
7.- MAINTENANCE		23
8.- TECHNICAL SERVICE		23
A.- CIRWATT communications diagram		24
B.- Changing the battery		25
C.-Quadrants		26

1.- INTRODUCTION

CIRWATT is a multi-purpose three-phase, four quadrant, digital meter. Its great versatility is its main feature, allowing it to adapt to the needs of the individual user.

It has been especially designed for installations where the electro-mechanical meters do not meet the current requirements. It is specifically for those installations that require a meter with a tariff system or where electricity billing is done by using load profiles.

2.- METER MODEL

The different meter configuration options covering the needs of each installation are shown below:

Meter version		CIRWATT	□ □□- □□□□- □□□- □□
4 wire / 3 wire	4	Connection mode	←
Class 0.5S active / Class 1 reactive	05	Accuracy	←
Class 0.2S active / Class 0.5 reactive	02		←
3x57/100 V (4 w)	L	Measured voltage	←
3x63.5/110 V (4 w)	M		←
3x127/220 V (4 w)	N		←
3x220/380 V (4 w)	O		←
3x230/400 V (4 w)	Q		←
3x110/190 V (4 w)	T		←
/5 (10) A three phase	T5	Measured current	←
/1 (2) A three phase	T1		←
50 Hz	A	Frequency	←
60 Hz	B		←
RS-232 / RS-232	1	Communications company/user	←
RS-232 / RS-485	2		←
Without card	0	Expansion card	←
3 inputs	1		←
4 outputs (optomos)	2		←
4 outputs (relay)	3		←
3 inputs + 4 outputs (optomos)	4		←
3 inputs + 4 outputs (relay)	5		←
Meter + Tariff setter + Power demand meter + Recorder	D	Mode	←
Version and/or protocols		Revision	←



The units for any power or energy data transmitted via the protocol will be kW, kWh, kvarh, regardless of how they are displayed.

4.1.- Display Modes.

4.1.1.- STAND BY Mode

Whenever READING mode is not activated by pressing the corresponding reading button/s, this screen will always appear as a default.

4.1.2.- READING Mode

This is activated by pressing , entering the variable selection menu. Pressing the  key moves through the menu and by pressing , enters the option that is flashing on the display. 60 seconds after the last press, the Display returns to STAND BY Mode.

4.2.- Types of screen.

There are three types of screen:

4.2.1.- Stand by screen

The STAND BY screen presents information without needing to use any of the equipment's buttons. This is typically used to show to the customer the necessary information for him to control measurement in the easiest way possible.

In the case of the 4x20 display (4 line screen), the second is a SCROLL screen (presenting different information in a different way after a time)

R00001	F00001
0000520	0.180
083550	29.1003
L3	T1 CNB

4.2.2.- Menu Screen

The MENU screen presents different options to access data screens or other secondary menu screens.

It is only used in READING mode.

Cont r at o 1
I nFo
I nFo Fab
L3 T1 CNB

4.2.3.- Data Screen.

The DATA screens show information on a specific group of data. It is only used in READING mode.

The data lines consist of two fields: one code (9 characters reserved) and the value of the data

00001480	1.18.1
00002378	1.18.1
00001891	158.1
L3	T1 CNB

4.3.- STAND BY mode screen

Screens	Text	Type	Comments
R	r.xxxxx P.xxxxx	FIXED	Link Address and Measurement Point
	0.18.0 XXXXXXXXXX 0.28.0 XXXXXXXXXX 0.58.0 XXXXXXXXXX 0.68.0 XXXXXXXXXX 0.78.0 XXXXXXXXXX 0.88.0 XXXXXXXXXX	SCROLL	Absolute active energy input total Absolute active energy output total Total Q1 absolute reactive energy Total Q2 absolute reactive energy Total Q3 absolute reactive energy Total Q4 absolute reactive energy
	DD-MM-YYYY HH:MM:SS	FIXED	Date and Local Time
	Alphanumeric indicators line		
	Q1	Quadrant (Q1, Q2, Q3, Q4) (See APPENDIX C)	
	1+2+3+	Presence of voltage in each phase with its corresponding current direction	
	T123	Current tariff periods in contracts 1, 2 and 3 respectively	
	C	Critical alarm due to internal or external incidents directly affecting measurement. This will be flashing.	
	N	Non critical alarm not affecting measurement creating a meter malfunction. This will be flashing.	
	B	Low battery alarm. This will be flashing.	
P	Special parameter mode activated		

Code field	B. C D. E. F xxxxxxxx
B.	1 character long. Defines the contract corresponding to the data. It may take the values 0,1,2 or 3. 0 is used for data not associated with any contract
C	1 or 2 characters long according to circumstances. Generally defines the physical or abstract size of the data. It may take the values defined in the IEC/UNE-EN62056-61 OBIS standard
D.	1or 2 characters long according to circumstances. Defines the type or result
E.	1 character long. Generally defines the tariff for the value defined by B, C and D. It may take the values 0 to 9 defined in the IEC/UNE-EN62056-61 OBIS standard
F	2 characters long. Defines the invoice period number from most recent to oldest of values defined by B, C, D and E. It may take the values defined in the IEC/UNE-EN62056-61 OBIS standard
Xxxxxxxx	Values

4.4.- READING screens mode.

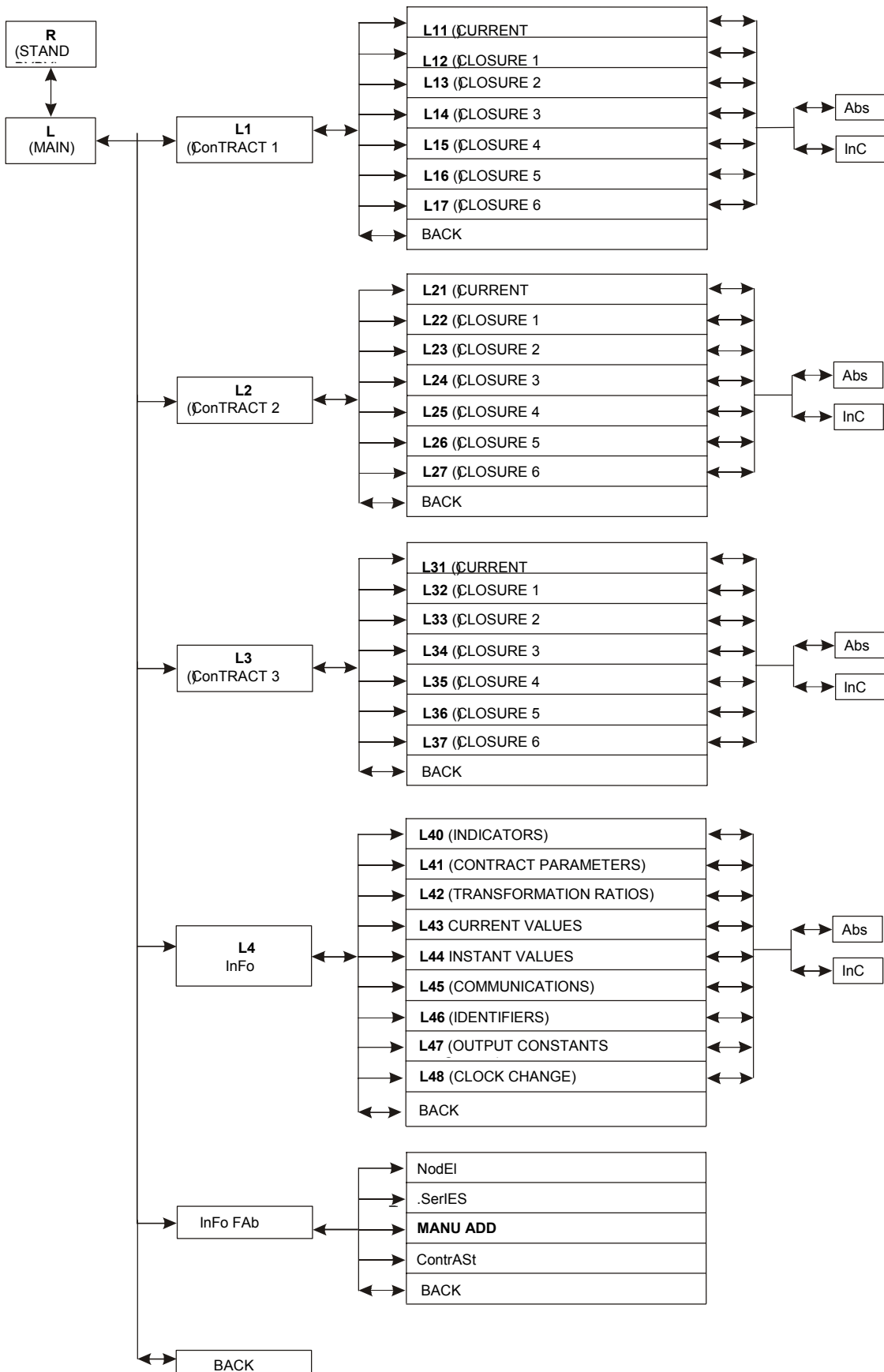

Screen L (Main)

This is the first screen accessed in READING Mode. It is a MENU screen to access other secondary MENU screens.

Screens	Text	Comments
L	ContrAct 1	Accesses current values for contract 1
	ContrAct 2	Accesses current values for contract 2
	ContrAct 3	Accesses current values for contract 3
	InFo	Accesses information not relevant to the contracts
	InFo FAb	Accesses extra information defined by the manufacturer:
	BaCK	Returns to STAND BY screen

4.4.1.1.- Screen L1 (CONTRACT 1)

This is the screen that accesses information on contract 1. It is a MENU screen. It accesses the secondary MENU screens.

Screens	Text	Comments
L1	Current	Accesses current values for contract 1
	CLOSURE 1 DD-MM-YY	this shows information on values from contract 1 closure 1(most recent).
	CLOSURE 2 DD-MM-YY	Accesses values for contract 1 closure 2
	CLOSURE 3 DD-MM-YY	Accesses values for contract 1 closure 3
	CLOSURE 4 DD-MM-YY	Accesses values for contract 1 closure 4
	CLOSURE 5 DD-MM-YY	Accesses values for contract 1 closure 5
	CLOSURE 6 DD-MM-YY	Accesses values for contract 1 closure 6 (oldest)
	Back	Returns to the previous screen

4.4.1.1.1. Screen L11 (CONTRACT 1): CURRENT

This screen shows information on the current values for contract 1. On entering this menu two options appear for data display: absolute values and incremental values.

The ABSOLUTE option (**ABS**) displays absolute values for active and reactive energy, as well as power excesses and maximum demands.

The INCREMENTAL option (**INC**) displays incremental values for active and reactive energy from the last bill closure, as well as power excesses and maximum demands.

If no option is selected, after the following press it will display data in Absolute values as a default.

Either of the two screens will only display information when it is active, that is to say, if certain tariffs or recordings such as excesses or maximums have not been activated, they will not appear on the information screen for these tariffs and recordings.

The codes for Absolute values are shown below:

L11	AbS (Absolute)	
	KWH	1.18.1
	KWH	1.18.2
	KWH	1.18.3
	KWH	1.18.4
	KWH	1.18.5
	KWH	1.18.6
	KWH	1.18.0

Tariff periods for Active Energy from the start of measurement (if active), included in the total (period 0)

1.18.x where x = tariff (period)

	KVARL	1.58.1	Tariff periods for Q1 Reactive Energy from the start of measurement (if active), included in the total (period 0) 1.58.x where x = tariff (period)
	KVARL	1.58.2	
	KVARL	1.58.3	
	KVARL	1.58.4	
	KVARL	1.58.5	
	KVARL	1.58.6	
	KVARL	1.58.0	
	Power Excesses	1.12.1	Excesses from the last bill closure (if active) 1.12.x where x = tariff (period)
	Power Excesses	1.12.2	
	Power Excesses	1.12.3	
	Power Excesses	1.12.4	
	Power Excesses	1.12.5	
	Power Excesses	1.12.6	
	MAXIMUMS	1.16.1	Maximums from bill closure (if active), included in the total (period 0) 1.16.x where x = tariff (period)
	MAXIMUMS	1.16.2	
	MAXIMUMS	1.16.3	
	MAXIMUMS	1.16.4	
	MAXIMUMS	1.16.5	
	MAXIMUMS	1.16.6	
	MAXIMUMS	1.16.0	

The codes for the absolute variable values are shown below:

L11	Inc (Incremental)		
	KWH	1.19.1	Consumption per Active Energy tariff period from the last bill closure (if active) included in the total 1.19.x where x = tariff (period)
	KWH	1.19.2	
	KWH	1.19.3	
	KWH	1.19.4	
	KWH	1.19.5	
	KWH	1.19.6	
	KWH	1.19.0	
	KVARL	1.59.1	Consumption per Q1 Reactive Energy from the last bill closure (if active), included in the total 1.59.x where x = tariff (period)
	KVARL	1.59.2	
	KVARL	1.59.3	
	KVARL	1.59.4	
	KVARL	1.59.5	
	KVARL	1.59.6	
	KVARL	1.59.0	
	Power Excesses	1.12.1	Excesses from the last bill closure(if active) 1.12.x where x = tariff (period)
	Power Excesses	1.12.2	
	Power Excesses	1.12.3	
	Power Excesses	1.12.4	
	Power Excesses	1.12.5	
	Power Excesses	1.12.6	
	MAXIMUMS	1.16.1	Maximums from the bill closure (if active), included in the total 1.16.x where x = tariff (period)
	MAXIMUMS	1.16.2	
	MAXIMUMS	1.16.3	
	MAXIMUMS	1.16.4	
	MAXIMUMS	1.16.5	
	MAXIMUMS	1.16.6	
MAXIMUMS	1.16.0		

4.4.1.1.2. Screen L12 (CONTRACT 1 :CLOSURE 01)

Shows information on the values for contract 1 from the last closure. The screen acts in the same way as the L11 screen, using Absolute or Incremental values.

		ABS (Absolute)	
L12	KWH	1.18.1.01	Tariff period for Active Energy from the start of measurement to the last closure (if active), including the total (period 0) 1.18.x.01 where x = tariff (period)
	KWH	1.18.2.01	
	KWH	1.18.3.01	
	KWH	1.18.4.01	
	KWH	1.18.5.01	
	KWH	1.18.6.01	
	KWH	1.18.0.01	
	KVARL	1.58.1.01	Tariff period for Q1 Reactive Energy from the start of measurement to the last (if active), including the total (period 0) 1.58.x.01 where x = tariff (period)
	KVARL	1.58.2.01	
	KVARL	1.58.3.01	
	KVARL	1.58.4.01	
	KVARL	1.58.5.01	
	KVARL	1.58.6.01	
	KVARL	1.58.0.01	
	Power Excesses	1.12.1.01	Excesses from last billing period (if active) 1.12.x.01 where x = tariff (period)
	Power Excesses	1.12.2.01	
	Power Excesses	1.12.3.01	
	Power Excesses	1.12.4.01	
	Power Excesses	1.12.5.01	
	Power Excesses	1.12.6.01	
	MAXIMUMS	1.16.1.01	Maximums from the last billing period (if active) included in the total 1.16.x.01 where x = tariff (period)
MAXIMUMS	1.16.2.01		
MAXIMUMS	1.16.3.01		
MAXIMUMS	1.16.4.01		
MAXIMUMS	1.16.5.01		
MAXIMUMS	1.16.6.01		
MAXIMUMS	1.16.0.01		

The codes for the incremental value variables are shown below:

		Inc (Incremental)	
L12	KWH	1.19.1.01	Consumption per Active Energy tariff periods from the last billing period (if active), included in the total (period 0) 1.19.x.01 where x = tariff (period)
	kWh	1.19.2.01	
	KWH	1.19.3.01	
	KWH	1.19.4.01	
	KWH	1.19.5.01	
	KWH	1.19.6.01	
	KWH	1.19.0.01	
	KVARL	1.59.1.01	Consumption per Q1 Reactive Energy tariff periods from the last billing period (if active), included in the total (period 0) 1.59.x.01 where x = tariff (period)
	KVARL	1.59.2.01	
	KVARL	1.59.3.01	
	KVARL	1.59.4.01	
	KVARL	1.59.5.01	
	KVARL	1.59.6.01	
	KVARL	1.59.0.01	
	Power Excesses	1.12.1.01	Excesses from last billing period (if active) 1.12.x.01 where x = tariff (period)
	Power Excesses	1.12.2.01	
	Power Excesses	1.12.3.01	
	Power Excesses	1.12.4.01	
	Power Excesses	1.12.5.01	
	Power Excesses	1.12.6.01	

	MAXIMUMS	1.16.1.01	Maximums form last billing period (if active) included in the total (period0) 1.16.x.01 where x = tariff (period)
	MAXIMUMS	1.16.2.01	
	MAXIMUMS	1.16.3.01	
	MAXIMUMS	1.16.4.01	
	MAXIMUMS	1.16.5.01	
	MAXIMUMS	1.16.6.01	
	MAXIMUMS	1.16.0.01	

4.4.1.1.3. Screen L13 (CONTRACT 1: CLOSURE 02)

Shows information on the values for contract 1 from the penultimate closure. The screen acts the same as for L12..

The information is displayed in exactly the same way as in screen L12, but field F will have the value 02 instead of 01.

Fox example: 1.18.1.02 → Absolute active energy consumed, from period 1, penultimate bill closure.

4.4.1.1.4. Screen L14 (CONTRACT 1: CLOSURE 03)

Shows information on the values for contract 1 from the ante penultimate closure. The screen acts the same as for L12..

The information is displayed in exactly the same way as in screen L12, but field F will have the value 03 instead of 01.

Fox example: 1.18.1.03 → Absolute active energy consumed, from period 1, bill closure 3.

4.4.1.1.5. Screen L15 (CONTRACT 1: CLOSURE 04)

Shows information on the values for contract 1 from closure 04. The screen acts the same as for L12..

The information is displayed in exactly the same way as in screen L12, but field F will have the value 04 instead of 01.

Fox example: 1.18.1.04 → Absolute active energy consumed, from period 1, bill closure 4

4.4.1.1.6. Screen L16 (CONTRACT 1: CLOSURE 05)

Shows information on the values for contract 1 from closure 05. The screen acts the same as for L12..

The information is displayed in exactly the same way as in screen L12, but field F will have the value 05 instead of 01.

Fox example: 1.18.1.05 → Absolute active energy consumed, from period 1, bill closure 5.

4.4.1.1.7. Screen L17 (CONTRACT 1) CLOSURE 06)

Shows information on the values for contract 1 from closure 06. The screen acts the same as for L12..

The information is displayed in exactly the same way as in screen L12, but field F will have the value 06 instead of 01.

Fox example: 1.18.1.06 → Absolute active energy consumed, from period 1, bill closure 6.

4.4.1.2.- Screen L2 (CONTRACT 2)

This screen accesses information on contract 2. It acts in the same way as L1.

All data screens that depend on this screen have the value 2 in group B of the code.

4.4.1.2.1. Screen L21 (CONTRACT 2: CURRENT)

This shows information on the current values for contract 2. It acts in the same way as screen L11, but changes the group B code from 1 to 2. The information is displayed in exactly the same way as in screen L11, except for Power Excesses, which will not appear

Data is displayed with zeros to the left to fill up the length of the display.

For example: 2.16.2 → Absolute, current maximum demand for period 2 and for contract 2.

4.4.1.2.2. Screen L22 (CONTRACT 2: CLOSURE 01)

This shows information on the current values for contract 2. It acts in the same way as screen L12, but changes the group B code from 1 to 2. The information is displayed in exactly the same way as in screen L11, except for Power Excesses, which will not appear

Data is displayed with zeros to the left to fill up the length of the data field display

For example: 2.18.2.01 → Absolute active energy consumed, from period 2, penultimate bill closure from contract 2.

4.4.1.2.3. Screen L23, L24, L25, L26, L27 (CONTRACT 2: CLOSURES 02 TO 06)

Shows information on the values for contract 2 from the closures prior to the last closure. It acts in the same way as screens L13-L17, but the group B code changes from 1 to 2 and does not display Power Excesses.

4.4.1.3.- Screen L3 (CONTRACT 3)

This screen accesses information on contract 3. It acts in the same way as screen L1,

4.4.1.3.1. Screen L31-L37 (CONTRACT 3: CURRENT AND CLOSURES 01 TO 06)

Import direction.

This shows information on the current values for contract 3. It acts in the same way as screen L11, but the group B code changes from 1 to 3 and does not display Power Excesses.

As contract 3 is valid for both the purchase and sale of energy, the data codes will depend on the contract being set for one or other energy direction This is applicable both for current values and for all the closures.

Export direction

This shows information on the current values for contract 3. It acts in the same way as screen L11, but the group B code changes from 1 to 3 and does not display Power Excesses.

		AbS (Absolute)	
L31-L37	KWH	3.28.1	Tariff periods for Active Energy from the start of measurement (if active), included in the total 3.28.x where x = tariff (period)
	KWH	3.28.2	
	KWH	3.28.3	
	KWH	3.28.4	
	KWH	3.28.5	
	KWH	3.28.6	
	KWH	3.28.0	
	KVARL	3.68.1	Tariff periods for Q2 Reactive Energy from the start of measurement (if active), included in the total 3.68.x where x = tariff (period)
	KVARL	3.68.2	
	KVARL	3.68.3	
	KVARL	3.68.4	
	KVARL	3.68.5	
	KVARL	3.68.6	
	KVARL	3.68.0	
	MAXIMUMS	3.26.1	Maximums from the bill closure (if active), included in the total 3.26.x where x = tariff (period)
	MAXIMUMS	3.26.2	
	MAXIMUMS	3.26.3	
	MAXIMUMS	3.26.4	
MAXIMUMS	3.26.5		
MAXIMUMS	3.26.6		
MAXIMUMS	3.26.0		

The codes for the incremental value variables are shown below:

		Inc (Incremental)	
L31-L37	KWH	3.29.1	Consumption per Active Energy tariff periods from the last billing period (if active), included in the total 3.29.x.01 where x = tariff (period)
	KWH	3.29.2	
	KWH	3.29.3	
	KWH	3.29.4	
	KWH	3.29.5	
	KWH	3.29.6	
	KWH	3.29.0	
	KVARL	3.69.1	Consumption per Q2 Reactive Energy tariff periods from the last billing period (if active), included in the total 3.69.x.01 where x = tariff (period)
	KVARL	3.69.2	
	KVARL	3.69.3	
	KVARL	3.69.4	
	KVARL	3.69.5	
	KVARL	3.69.6	
	KVARL	3.69.0	
	MAXIMUMS	3.26.1	Maximums from the last billing period (if active) included in the total 3.26.x.01 where x = tariff (period)
	MAXIMUMS	3.26.2	
	MAXIMUMS	3.26.3	
	MAXIMUMS	3.26.4	
MAXIMUMS	3.26.5		
MAXIMUMS	3.26.6		
MAXIMUMS	3.26.0		

4.4.1.4.- Screen L4 (INFORMATION)

This screen accesses information not relevant to the contract billing values. It is a MENU screen. It accesses other dependent MENU screens as shown below:

Screens	Text	Comments
L40	OPERATIONAL INDICATORS	To check the proper working of the equipment in all its basic aspects during installation and for subsequent in situ checks
L41	POWER CONTRACTS	This is used to indicate the values of the contracted powers. It only applies to power excesses in Contract 1
L42	TRANSFORMATION RATIOS	This shows information on transformation ratios
L43	CURRENT VALUES	Shows information on current power, maximum, totals and power form the last integration period (As a default: 15 minutes)
L44	INSTANT VALUES	This shows information on the instant values of different electrical magnitudes
L45	COMMUNICATIONS	This shows information on the different parameters of the communications ports
L46	IDENTIFIERS	This shows information on the equipment's different identifiers, included those for the IEC870-5-102 protocol
L47	OUTPUT CONSTANTS	This shows information on the output impulse values
L48	TIME CHANGE	This shows information on the dates of the time change.
L49	BACK	Returns to the previous screen

4.4.1.4.1. Screen L40 (INFORMATION: INDICATORS)

This screen shows information on the operating indicators. These are used to check the proper working of the equipment in all its basic aspects during installation and for subsequent in situ checks. It is a DATA screen

As these indicators do not correspond to a specific contract, but is data general to all, field B takes the value 0.

Screen	Text	Code	Comments
L40	INDICATORS	0.13.38 e.g. 1	ACTIVE QUADRANT: This indicates the direction of the active or reactive energy or quadrant (1,2,3 or 4)
		0.12.38 e.g. 123	PRESENCE OF VOLTAGE: Indicates the presence of voltage in each phase (123 if there is voltage in all, blank if there is no voltage)
		0.11.38 e.g. 120	CURRENT DIRECTION: This indicates the direction of importation (+) or exportation (-) in each phase (111 if they are imported, 222 if exported, 000 if there is none)
		0.18.128 e.g. 633	ACTIVE TARIFF FOR EACH CONTRACT: This indicates the active tariff at the time of reading for each contract (contract 1, contract 2, contract 3)(values form 1 to 6 for each contract)
		0.96.2.4 e.g. 0	PARAMETERISATION MODE: This indicates if the parameterisation mode is enabled (0 disabled, 1 enabled)
		0.96.5.0 e.g. cnb	ALARMS: This indicates the alarms defined in section 4.3. The data field will display the letters cnb, which will become active according to the type of alarm.

4.4.1.4.2. Screen L41 (INFORMATION: CONTRACT PARAMETERS)

This screen shows information on the contracted powers for contract 1. It only applies to power excesses in Contract 1. It is a DATA screen

Screen	Text	Code	Comments
L41	CONTRACT POWERS	1.135.1	CONTRACTED POWERS: This is for the values of the contracted powers in kW to 2 decimals that will be used to calculate excesses 1,135.x where x = tariff (period)
		1.135.2	
		1.135.3	
		1.135.4	
		1.135.5	
		1.135.6	

4.4.1.4.3. Screen L42 (INFORMATION: TRANSFORMATION RATIOS)

This screen shows information on the transformation ratios. As this data does not correspond to any specific contract but is data general to all, field B will have the value 0. It is a DATA screen

Screen	Text	Code	Comments
L42	TRANSFORMATION RATIOS	0.04.2	CURRENT RATIO PRIMARY : This shows the current ratio primary to 1 decimal
		0.04.5	CURRENT RATIO SECONDARY: This shows the current ratio secondary to 1 decimal
		0.04.3	VOLTAGE RATIO PRIMARY : This shows the voltage ratio primary to 1 decimal (compound voltage)
		0.04.6	VOLTAGE RATIO SECONDARY : This shows the voltage ratio secondary to 1 decimal (compound voltage)

4.4.1.4.4. Screen L43 (INFORMATION: CURRENT VALUES)

This screen shows information on current values power, maximum, totals and power from the last integration period (As a default 15 minutes). As this data does not correspond to any specific contract but is data general to all, field B will have the value 0. It is a DATA screen

Screen	Text	Code	Comments
L43	CURRENT	0.18.0	TOTAL A+: This shows the current total for Active Energy taken from the system
		0.28.0	TOTAL A-: This shows the current total for Active Energy taken from the system
		0.58.0	TOTAL R1: This shows the current total for Reactive Energy in Quadrant 1
		0.68.0	TOTAL R2: This shows the current total for Reactive Energy in Quadrant 2
		0.78.0	TOTAL R3: This shows the current total for Reactive Energy in Quadrant 3
		0.88.0	TOTAL R4: This shows the current total for Reactive Energy in Quadrant 4
		0.14.0	CURRENT INPUT POWER: This shows the average input power that is being integrated during the current integration period

		0.24.0	CURRENT OUTPUT POWER: This shows the average output power that is being integrated during the current integration period
		0.15.0	LAST PERIOD INPUT POWER: This shows the average input power that is being integrated during the last integration period
		0.25.0	LAST PERIOD OUTPUT POWER: This shows the average output power that is being integrated during the last integration period

4.4.1.4.5. Screen L44 (INFORMATION: INSTANT VALUES)

This screen shows information on the instant values of different electrical magnitudes. As this data does not correspond to any specific contract but is data general to all, field B will have the value 0.

Screen	Text	Code	Comments
L44	INSTANT	0.327.0	VOLTAGE PER PHASE: This shows the instant current values in each phase.
		0.527.0	
		0.727.0	
		0.317.0	CURRENT PER PHASE: This shows the instant Current values in each phase.
		0.517.0	
		0.717.0	
		0.337.0	COS Φ PER PHASE: This shows the instant cos Φ values in each phase.
		0.537.0	
		0.737.0	
		0.17.0	INSTANT ACTIVE POWER: This shows the total instant Active Power in each of the three phases with its sign.
		0.37.0	INSTANT REACTIVE POWER: This shows the total instant Reactive Power in each of the three phases with its sign.
		0.137.0	AVERAGE POWER FACTOR: This shows the average instant Power Factor in the three phases.

4.4.1.4.6. Screen L45 (INFORMATION: COMMUNICATIONS)

This screen shows information on the different parameters of the communications ports. As this data does not correspond to any specific contract but is data general to all, field B will have the value 0.

Screen	Text	Code	Comments
L45	COMMUNICATIONS	0.00.0	OPTICAL SERIES PORT SETTING: 000000n (009600 speed, n parity)
		0.00.1	ELECTRICAL SERIES PORT SETTING 1: 000000n (009600 speed, n parity)
		0.00.2	ELECTRICAL SERIES PORT SETTING 2: 000000n (009600 speed, n parity)
		0.00.3	ELECTRICAL SERIES PORT 1 MODEM START UP MODE : It will appear as data for the ASDU 142 of the protocol

4.4.1.4.7. Screen L46 (INFORMATION: IDENTIFIERS)

This screen shows information on the equipment's different identifiers, including those for the IEC870 protocol. As this data does not correspond to any specific contract but is data general to all, field B will have the value 0.

Screen	Text	Code	Comments
L46	IDENTIFIERS	0.00.5	LINK ADDRESS
		0.00.6	MEASUREMENT POINT ADDRESS
		0.00.7	DATE OF THE COMMUNICATIONS PROTOCOL VERSION: (DD-MM-YY), data from the ASDU 142 of the protocol will be shown
		0.02.0	EQUIPMENT'S FIRMWARE VERSION: data from the ASDU 142 of the protocol will be shown
		0.08.4	INTEGRATION PERIOD OF THE FIRST LOAD CURVE: this shows the integration period in minutes, 60 minutes as a default.
		0.08.5	INTEGRATION PERIOD OF THE SECOND LOAD CURVE: this shows the integration period of the second load curve in minutes, 15 minutes as a default.

4.4.1.4.8. Screen L47 (INFORMATION: OUTPUT CONSTANTS)

This screen shows information on the impulse values of the outputs. As this data does not correspond to any specific contract but is data general to all, field B will have the value 0.

Screen	Text	Code	Comments
L47	OUTPUT CONSTANTS	0.03.3	OUTPUT 1
		0.03.4	OUTPUT 2
		0.03.5	OUTPUT 3
		0.03.6	OUTPUT 4

Options for each type of output are:

- Ax Y: x = 1:imported active / x= 2: exported active / Y = impulse weight
- Rx Y: x = quadrant no. (reactive quadrant x) / Y = impulse weight
- Pow : Power demand meter
- C x P y: x = Contract No. / and = tariff period no. (the output indicates the tariff)

4.4.1.4.9. Screen L48 (INFORMATION: TIME CHANGE)

This screen shows information on the dates of the time changes. As this data does not correspond to any specific contract but is data general to all, field B will have the value 0.

Screen	Text	Code	Comments
L48	TIME CHANGE	0.00.8	WINTER-SUMMER TIME CHANGE: Shows the date and time of the Winter-Summer time change
		0.00.9	SUMMER-WINTER TIME CHANGE: Shows the date and time of the Summer-Winter time change

4.4.1.5.- Screen L5 (INFO FAB)

4.4.1.5.1. Model

This screen identifies the model of the equipment. (See section 2 Meter Model).

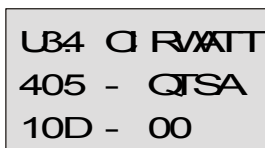

4.4.1.5.2. Series number

This screen identifies the series number of the equipment

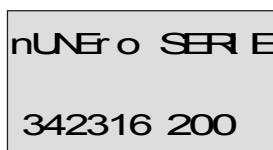

4.4.1.5.3. Date of manufacture

This screen identifies the date of manufacture of the equipment.

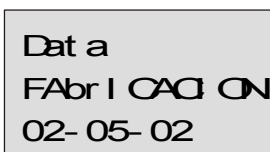

4.4.1.5.4. Contrast

The % display contrast is shown on this screen

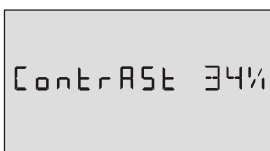

5.- TECHNICAL FEATURES

The electrical and mechanical design of the CIRWATT has incorporated all applicable standards for electronic meters.

Power supply	Self supplied
Nominal voltage:	According to model:
Consumption:	< 2W
Frequency:	50 Hz or 60 Hz (according to model:)
Operating temperature:	-20 ° C to + 60 ° C
Voltage Measurement:	
Connections:	3 or 4 wire in the same equipment
Reference voltage:	3 x 63.5/110V, 3 x 110/190V 3 x 127/220V 3 x 230/400V (according to type)
Frequency:	50 Hz or 60 Hz
Current measurement:	
Nominal current (base):	.../5A or .../ 1 A for direct measurement
Maximum current:	10 A or 20 A (2 x In) for indirect measurement
Accuracy: (According to model)	
Active Energy:	Class 0.2S or 0.5S (IEC 60687)
Reactive energy:	Class 0.5S or 1 (IEC 61268)
Data memory:	
Type:	FLASH (non volatile memory)
Setting	FIFO
Capacity:	Events: 512 events
	Tariffs: 21 months per contract
	Load curve: 213 days (hourly)
	2nd Load curve: 53 days (1/4 hourly)
Battery:	
Type:	Lithium
Life:	10 years (50% load)
Operation without battery nor voltage:	Maximum 24 hours
Clock:	
Type:	Quartz oscillator/Mains frequency
Accuracy:	< 0.5 s per day at 25 °C

Inputs:	Free of potential: 60-300 V AC.
Outputs: Type:	Free of potential Mechanical or optoMOS (According to model)
– Mechanical relays:	<ul style="list-style-type: none"> – Maximum operating power: 1,500 W. – Maximum operating voltage: 400 V AC. – Maximum operating current: 6 A AC. – Mechanical life 30·10⁶ operations. – Switching speed: low.
– Solid state relays: (optomos)	<ul style="list-style-type: none"> – Maximum operating voltage: 400 V AC. – Maximum operating current: 150 mA AC. – Switching speed: high.
LED outputs Maximum cadence	20000 pulses / kW.h or kvar.h
Safety:	Category III (110 V) according to EN-61010
Assembly features: Casing: Dimensions:	<p>According to DIN 43859 Standard According to DIN 43857 Standard</p>
Optical Reader: Protocols:	<p>Reading / Writing for local access. IEC 870-5-102, Modbus-RTU, Zmodem and IEC 6117</p>
Series port (According to model): Indirect meters:	<p>RS-232 or RS-485 (Reading Only) Modbus-RTU and Zmodem</p> <p>RS-232 (Reading / Writing) IEC 870-5-102, Modbus-RTU and ZModem</p> <p>RS-232 or RS-485 (Reading / Writing) IEC 870-5-102, Modbus-RTU and ZModem</p>
R2 / COM2: User Protocols:	
R1 / COM1: Company Protocols:	
Direct connection meters: R1 / COM1: Protocols:	
Tests/Standards: EN 60687 EN 61036 EN 55022 EN 61000-4-6 EN 61000-4-8	<p>Standard on static, active energy meters for alternating current, class 0.2S and 0.5S</p> <p>Standard on static, active energy meters for alternating current, class 1</p> <ul style="list-style-type: none"> • Conducted emissions: Class B • Radiated emissions: Class B • Immunity to RF fields joined to cables (common mode): 10 V • Immunity to magnetic fields at mains frequency: 30 A/m

6.- INSTALLATION AND START-UP

6.1.- Installing the equipment

The meter has been designed in accordance with the DIN 43857 standard defining the sizes and the mounting points.



It must be remembered that once the equipment is connected, the terminal may be dangerous when touched and opening the covers or removing pieces may access parts that are dangerous when touched. The equipment must not be used until it is fully installed.

Warning : All connections must be inside the terminal cover.

6.2.- Meter terminals ratio (see label on terminal cover)

	<p>No. Terminal description</p> <p>Lower board</p> <p>1 Current input IL1 – S1</p> <p>2 Measurement UL1</p> <p>3 Current input IL1 – S2</p> <p>4 Current input IL2 – S1</p> <p>5 Measurement UL2</p> <p>6 Current input IL2 – S2</p> <p>7 Current input IL3 – S1</p> <p>8 Measurement UL3</p> <p>9 Current input IL3 – S2</p> <p>11 Neutral measurement</p> <p>R1 RS-232 Communications</p> <p>R2 RS-232 or RS-485 Communications</p>
	<p>Upper board</p> <p>21 Output Relay 1</p> <p>22 Output Relay 1</p> <p>23 Output Relay 2</p> <p>24 Output Relay 2</p> <p>25 Output Relay 3</p> <p>26 Output Relay 3</p> <p>27 Output Relay 4</p> <p>28 Output Relay 4</p> <p>29 Output Relay 4</p> <p>30 Contact input 1</p> <p>31 Contact input 1</p> <p>32 Contact input 2</p> <p>33 Contact input 2</p> <p>34 Contact input 3</p> <p>35 Contact input 3</p> <p>Not used</p>

NOTE: The current inputs are isolated.

6.3.- Meter connection diagrams

Each CIRWATT model is especially designed for a different type of three phase system, therefore the connection diagram will vary.

The required connection diagram is located inside the terminal cover.

- Indirect meters: ... / 5A and .../ 1A

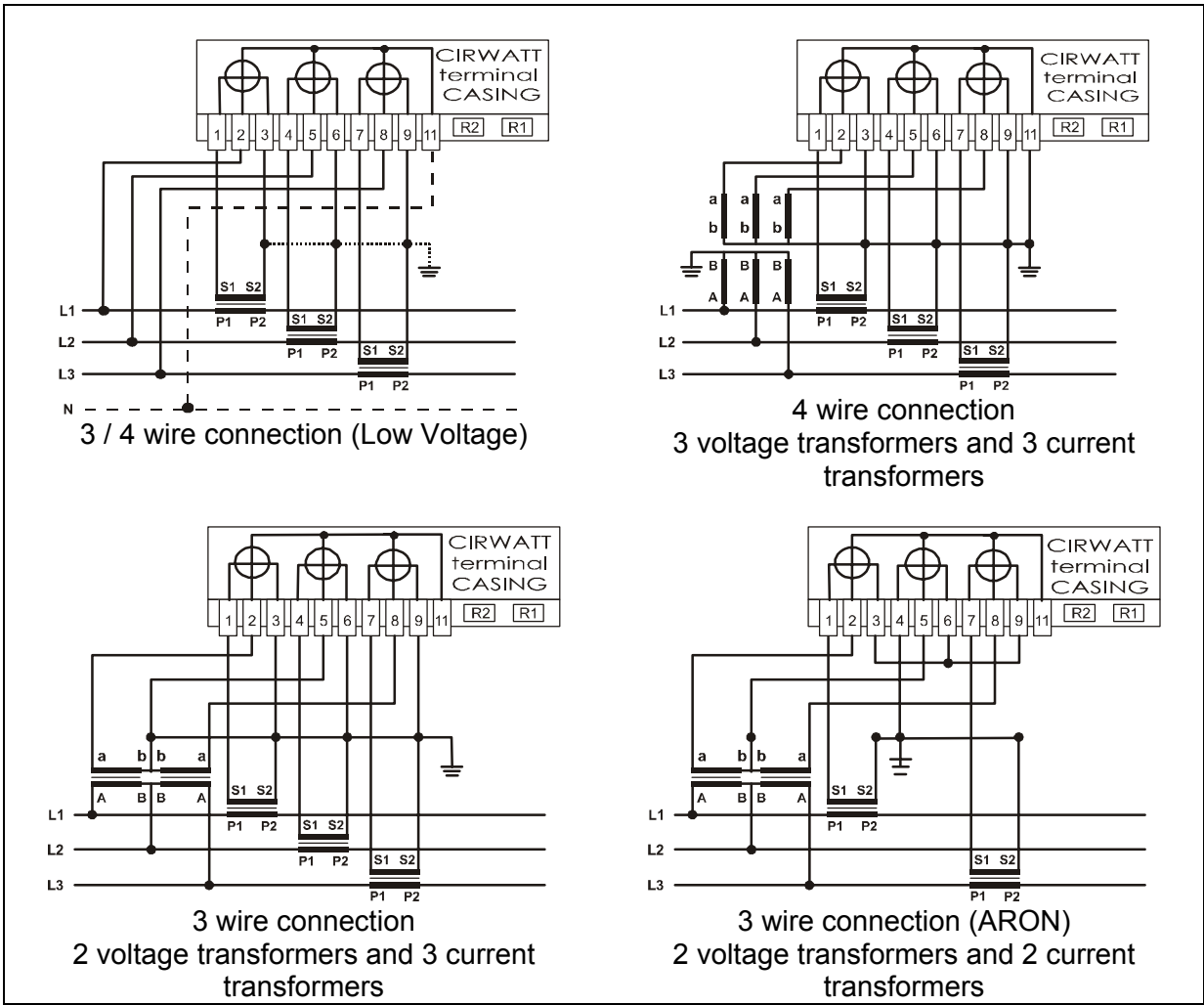

7.- MAINTENANCE

The only maintenance required by the CIRWATT is replacing the battery when it has run out.

It is advised that the battery is changed when the number of hours of use has reached its average working life (10 years).

The hours of use may be easily checked via the display.

8.- TECHNICAL SERVICE

In the event of any equipment failure or any operational queries please contact the technical service:

CIRCUTOR S.A. - After sales service.
Vial Sant Jordi, s/n
08232 Viladecavalls
Tel - (+34) 93 745 29 00
Fax – (+34) 93 745 29 14
E-mail - central@circutor.es

A.- CIRWATT connection diagram

- It has 2 series port (Plus the Optical port): company port (RS 1) and user port (RS-2)
- **R1:** complete RS-232 port for on site or remote communications (modem) → Reading and setting
- **R2:** RS-232 or RS-485 port (according to model) for on site or remote communications → Reading
- Connection diagram

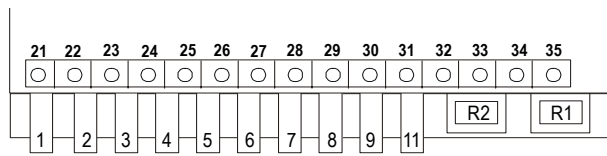

- Connection to a PC

RJ Cirwatt Connector	RS-232		RS.485	
	CIRWATT	P.C. (DB9)	CIRWATT	Converter (DB9)
<p>Front view</p>	1 – GND	5 – GND	1 – GND	5 – GND
	2 – RX	3 – Tx	2 –Tx/Rx (-)	2 – Tx/Rx (-)
	3 – TX	2 – Rx	3–Tx/Rx (+)	1 – Tx/Rx (+)
	4–CTS	7 – CTS		
	5 - RTS	8 – RTS		
	6 – GND	5 – GND	6 – GND	5 – GND

- RS-232 to external Modem

RJ Cirwatt Connector	CIRWATT	Modem (DB9)	Modem (DB25)
<p>Front view</p>	1 – GND	5 – GND	7 – GND
	2 – Rx	2 – Rx	3 – Rx
	3 – Tx	3 – Tx	2 – Tx
	4 –CTS	7 – CTS	5 – CTS
	5 – RTS	8 – RTS	4 – RTS
	6 – GND	5 – GND	7 – GND

B.- Changing the Battery

Follow the steps below to change the battery:

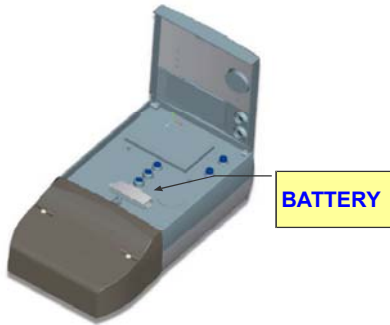

- Remove seal "Meter cover".
- Loosen the two screws that hold the battery compartment cover.
- Remove the battery compartment cover.
- Change the battery.
- Attach the battery compartment cover.
- Tighten the screws that hold the cover.

The battery may be changed with or without the equipment being connected. The equipment has a SUPERCAP that keeps the meter's clock running for 24 hours, in the event of the equipment being disconnected.

The battery reference number is written on the cover that holds the battery (CR2477N)

C. Quadrants

Below is a diagram showing the power sign and its corresponding energy quadrant used by the CIRWATT meter.

