

**THREE PHASE METER EDMK**

The EDMk three-phase electronic energy meter is capable of measuring consumed and generated energy (four quadrants): Active energy (consumed and generated), inductive reactive energy (consumed and generated) and capacitive reactive energy (consumed and generated), plus metering partial energies.

Measurements are in true effective value, via three AC voltage and neutral inputs and three AC current inputs. (via .../5A, .../1A or .../250mA for MC3 current transformers). The parameters measured and calculated are shown in the variables table

This manual describes how to configure and use the EDMk energy meter. This manual may be found in electronic format on the CIRCUTOR website: [www.circutor.com](http://www.circutor.com)

The device has to be provided of an magnetic-thermal switch to be disconnected. The fuses has to be type gl (IEC 269) or type M between 0,5 to 2 A.



Before any maintenance, modification to the connections, repair, etc., the equipment must be disconnected from the supply. If any operation or protection fault is suspected the equipment must remain out of service ensuring against any accidental reconnection. The equipment is designed to be changed quickly in the event of any breakdown

**1. KEYBOARD FUNCTION.**

The button allows the user to move through the different energy groups (if any): tariff one and partial tariff, or tariff one, two, three and partial tariff (EDM3k type). It used in the set up menu it is used to enter the data and move on to the next parameterisation screen.

The button allows the active or reactive energy display options to be displayed. It is used in the set up menu to increase the value by one digit if a variable has been entered or selected.

Generated or consumed energy can be selected using in the option. Inductive or capacitive energy can be selected in the reactive option. In the set up menu is used to move the cursor among the digits.

The button allows the display to come on in the absence of any power supply. This function allows the on site reading of meters when the device is out of service. This option is available when the meter has an optional station installed inside (see price list M3).

The button allows a quick access to the device's full parameterisation menu. To access this menu, press the button for less than one second.

The button deletes partial energies. To do this, press the button for less than 4 seconds. The message will then display "donE", indicating that these meters have been successfully started (active and reactive).

The button starts the meter in one step only with the minimum setting for the meter. (see section Parameterisation in one step only).

**2. STARTING UP**
**2.1. Previous information**

This option is only valid for installations where there is no voltage transformer to measure. Voltage is only measured directly (300V AC f-N / 500V AC f-f) and current measurement is via secondary external current transformers of .../1A, .../5A or in model MC3 of .../250 mA.

**2.2. Parameterization in one step only**

Keeping the button pressed for 1 second, the energy meter enables the current primary and secondary parameterisation on screen.

Using and buttons the value of the current transformer primary and secondary is validated using the button.

**3. COMPLET MENU**

Using the complete parameterisation of the meter, all setting options can be set. These options affect the setting of the external voltage transformers, if any, as well as the omission of energy meters which the customer believes to of little relevance or are not required in their installation.

**3.1. Voltage transformer**

On screen the words "PRI U" appear followed by 6 digits. These allow the voltage transformer primary to be set (from 1 to 999.999).

On screen the words "SEC U" appear followed by 3 digits. These allow the voltage transformer secondary to be set (from 1 to 999).

**3.2. Current transformer**

On screen the words "PRI R" appear followed by 4 digits. These allow the current transformer primary to be set (from 1 to 9.999).

On screen the words "SEC R" appear followed by the number 5 or 1. These allow the installed current transformer secondary ratio to be set (5 = .../ 5A or 1 = .../ 1A).

\* The option secondary in model MC3 does not exist is always 250mA

**3.3. Measurement in 2 or 4 quadrants**

On screen the words "QUAD" appear; one of the two available options must be selected: 2 = power consumption or 4 = consumption and generation.

**3.4. Backlight disconnection time setting**

On screen the words "DISP OFF" appear; the time the backlight is on can be set after pressing the keypad. The backlight is permanently on if 00 is set.

**3.5. Display or not reactive energy**

On screen the words "REACT" appear; this option allows the reactive energy to be displayed or omitted ("YES" or "NO").

**3.6. Display partial energy counters**

On screen the words "PART" appear; this option allows the partial active and reactive energy to be displayed or omitted ("YES" or "NO"). In the event of omission, the meter does not show energy and stops metering energy.

**3.7. Energy output pulse settings**

The screen shows "OUT ACT"; the energy to be associated to digital output 1 must be selected: Consumed active energy (IMPORT) or generated (EXPORT); once the data has been entered with , the W·h value must be entered by pressing. The screen shows "Out REA": the reactive energy to be associated to digital output 2 must be selected: L / C - / L - / C; once the data has been entered with the button , the var·h value must be entered by pressing the keypad. In case of selecting 2 quadrants (see section 3.3. Measurement in 2 or 4 quadrants), only are available L or C.

**4. DEFAULT SETTINGS**

The EDMK-ITF-C2 electronic three-phase meter is supplied with the following default settings:

VARIABLE	POINT	VALUE
Primary voltage	3.1	000001
Secondary voltage	3.1	001
Primary current	3.2	0005
Secondary current	3.2	5
Measure in 2 or 4 quadrants	3.3	2
Backlight disconnection	3.4	10
Reactive energy display	3.5	no
Partial energy counters	3.6	no
Energy pulses		
- Active energy	3.7	IMPORT
- w·h / pulse	3.7	1000
- Reactive energy	3.7	L
- var·h / pulse	3.7	1000

**5. TARIFFS (EDM3K MODEL)**

The tariff time is carried out using hardware. The equipment has a common and two inputs free of voltage to select the type of tariff required (Tariff 1, Tariff 2 or Tariff 3).

- Tariff 1: Without any bridge between terminals
- Tariff 2: Bridge between terminal A and S
- Tariff 3: Bridge between terminal B and S

**6. COMMUNICATIONS (RS-485 C2 MODEL)**
**6.1. Programming parameters**

Configurable parameters in the parameterisation menu:

- "NPER": Peripheral number 001 to 255
- "BAUD": Baud rate 1200-2400-4800-9600-19200
- "BITS": Length 8 bits
- "PART": No, Even, Odd
- "STOP": Stop bits 1 or 2

Default settings 001 / 9600 / 8 / N / 1

**6.2. Communication protocol**

The EDMk meter uses MODBUS RTU © communication protocol and network protocol RS-485. The format is as follows:

QUESTION: NP FT AAAA NNNN CRC

- NP: 1 Byte Peripheral number
- FT: 1 Byte Function 04 reading of n Words
- AAAA: 2 Bytes Address of 1st register
- NNNN: 2 Bytes Number of registers to be requested
- CRC: 1 Byte Cyclic Redundancy Checking

In the MODBUS © recordings, the energy is accumulated in kW·h x 100 (2 decimal points) with a length of 2 Words.

**6.3. Modbus/RTU © memory map**

PARAMETER	REGISTER
Active Energy (+)	00-01
Active Energy (-)	02-03
Inductive reactive energy (+)	04-05
Capacitive reactive energy (-)	06-07
Inductive reactive energy (-)	08-09
Capacitive reactive energy (+)	0A-0B
Partial active energy (+)	30-31
Partial active energy (-)	32-33
Partial inductive reactive energy (+)	34-35
Partial capacitive reactive energy (-)	36-37
Partial inductive reactive energy (-)	38-39
Partial capacitive reactive energy (+)	3A-3B

**6.4. Communications connections**

Description of connection for the RS-485 bus, for communication via an Intelligent Converter (485-RS232), or via an Ethernet Converter (Transparent / Modbus/TCP).

EDMk-ITF-RS485-C2	Intelligent converter	Ethernet converter
M31751	M54020	M54031 / M54032
BORNES RS-485	BORNES RS-485	RS-485 / RS-232
A (+)	1 (A)	A
B (-)	2 (B)	B
S (GND)	5 (GND)	S

**6.5. Communications description**

One or more EDMk meters can be connected to a computer or PLC. As well as the usual operation of each piece of equipment, this system may centralize data at one single point. The EDMk has an RS-485 series communications output. If more than one analyzer is connected to one RS-485 communication bus, it is necessary to assign to each a peripheral address (from 01 to 255) so that the remote computer or PLC sends data on different measured or calculated recordings to those addresses. The RS-485 connection is made with woven mesh shielded communications cables, with a minimum of three wires and with a maximum distance between remote computer and the last analyzer of 1.200 metres. This RS-485 series bus can connect up to a maximum of 32 devices. The EDMk meter communicates using the MODBUS RTU® protocol (Pulling Question / Answer).

**7. DISPLAY / LEDS**



The EDMk energy meter display is divided into two sections: the first of these (on the upper section) displays the value of the energy meters (Active energy and Inductive reactive energy or Capacitive). The second shows the measurement, in real time, being taken by the meter at that time.

- CPU CPU led indicates that the device is working right flashing in one second intervals.
- COMM COMM led flashes quickly in varible intervals when the device is receiving or sending information throught is RS-485 port.

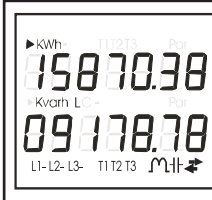

- L1-, L2- and L3- shows that the device has measured voltage in each phase. If one of these does not exist, the corresponding identification number does not appear. The symbols appearing behind each phase (L) indicate the direction of the current in the current transformers, showing if the point of measurement is consuming or generating energy ( L1, L2 and L3 flashing, informs of possible errors of connection of current transformers).
- T1, T2 y T3 (identification only available on the EDM3k; shows the tariff selected for that time, independently from the tariff displayed on the upper section.
- The  $\Sigma$  symbol indicates that load is inductive. The  $\Pi$  symbol indicates a capacitive load.
- The  $\rightarrow$  symbol shows that the meter is the first and fourth quadrant (consumption). The  $\leftarrow$  symbol indicates that the meter is in the second and third quadrant (generation).

**8. CONNECTIONS**

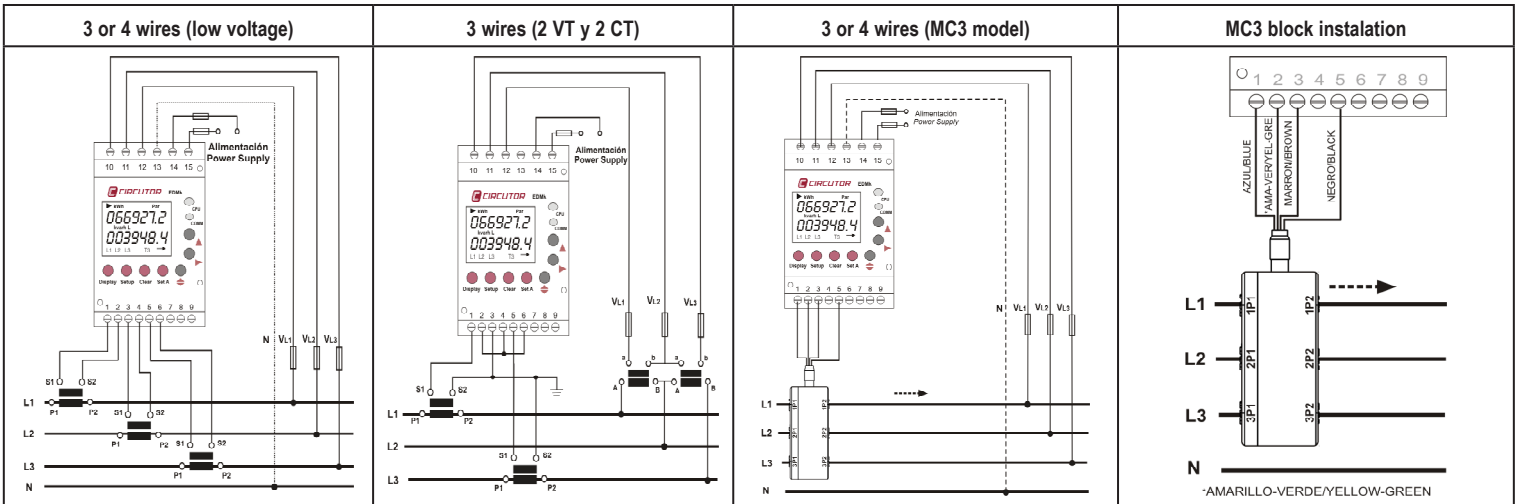

**9. TECHNICAL CHARACTERISTICS**

POWER SUPPLY	TIPO C.A.	TIPO C.C. & C.A.	MEASUREMENT CIRCUIT	
Single phase	230 V a.c.	85...265 Va.c/ 95...300 Vd.c	Rated voltage	300 V a.c. f-N / 500 V a.c. f-f
Voltage tolerance	-15 %... +10 %		Frequency	45...65 Hz
Frequency	45...65 Hz	0...65 Hz	Rated current	.../5 or .../1
Maximum burden	5 V-A		Permanent overload	1,2 In
Operating temperature	-20 °C...+60 °C	-20 °C...+60 °C	Voltage circuit burden per phase	0,3 V-A
Humedity (without condensation)	5 %...95 %		Current circuit burden per phase	0,3 V-A at 5 A. ó 0,06 V-A at 1 A
Maximum altitude	2.000 m		<b>PULSE OUTPUT TRANSISTOR FEATURES</b>	
<b>MECHANICAL FEATURES</b>			Opto-insulated transistor (open collector)	NPN
Casing material	Self extinguishing VO plastic		Maximum operating voltage	24 V c.c.
Protection assembled device (front)	IP 51		Maximum operating current	50 mA
Protection non assembled device	IP 31		Maximum frequency	5 imp / s
Supply and voltage measure wires	Minimum section 1 mm²		Pulse length	50 ms
Secondary current transformers wires	Minimum section 2,5 mm²		<b>TRANSISTOR OUTPUTS CONNECTIONS</b>	
Dimensions (mm)	85 x 52 x 70 (3 steps)		Output 1	Terminal 9 - 8
<b>CLASS</b>			Output 2	Terminal 7 - 8
Accuracy class in active energy	Class 1 - EN62053-21		<b>MAXIMUM COUNTER VALUE</b>	
Accuracy class in reactive energy	Class 2 - EN62053-23		9999999 kW	
<b>STANDARDS</b>			<b>SAFETY</b>	
EN62052-11, EN62053-21, EN62053-23, EN61010-1			Category III EN61010-1. Class II double insulation against electric shock.	

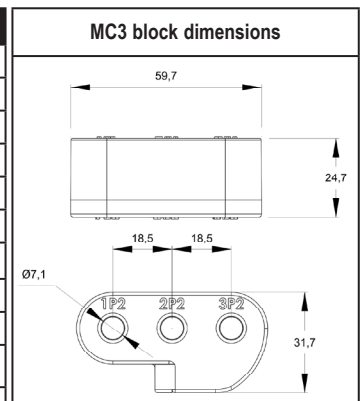

**10. TECHNICAL ASSISTANCE SERVICE**

In the event of any equipment failure or any operational queries please contact the technical service of CIRCUTOR, SA.

CIRCUTOR, SA. – After sales service.

Vial Sant Jordi s/n  
08232 Viladecavalls, Barcelona

Tel.: (+34) 93 745 29 00  
Fax: (+34) 93 745 29 14  
e-mail: central@circutor.es