



3 PHASE ENERGY ELECTRONIC METERS

MKT & MKT2

(Code 7 71 071 to 7 71 083)

INSTRUCTION MANUAL

(M 981 200 / 00 A)

(c) CIRCUTOR S.A.

3 PHASE ACTIVE & REACTIVE ENERGY ELECTRONIC METERS

1.- BASIC INSTRUCTIONS

1.1.- Delivery spot check

This manual is issued to help all the ACTIVE ENERGY METERS users to install and use them in order to get the best from them. After receiving the unit please check the following points:

- (a) Does this device corresponds to your order specifications?
- (b) Check if any damage was done during the shipment process.
- (c) Verify that it includes: One instruction manual .



1.2.- Safety considerations

This manual contains information and warnings that must be followed for operating the ENERGY METER safely and maintaining the instrument in a safe operating condition.

2.- MAIN CHARACTERISTICS

Three phase electric energy meters for low voltage networks at 400 V a.c. or 230 V a.c., provided with mechanical rotary display, that are designed to measure the electric energy consumed by any three phase circuit (3 or 4 wires). Those are suitable for such installations where a partial energy consumption analysis is required. Direct connection for the voltage signal (3 x 400 V a.c or 3 x 230 V a.c) and also for the current signal (input through internal current transformers) .

AVAILABLE MODELS:

a.- ACTIVE ENERGY METER TYPE MKT

3 phase active energy meter single tariff, direct current input . Display by means of an electromecanic integrating meter in kW.h.

<i>Code</i>	<i>type</i>	<i>Current</i>
7 71 071	MKT-20 - 230 V	Ib = 20 A - Imax = 60 A
7 71 072	MKT-20 - 400 V	Ib = 20 A - Imax = 60 A
7 71 074	MKT-40 - 230 V	Ib = 40 A - Imax = 120 A
7 71 075	MKT-40 - 400 V	Ib = 40 A - Imax = 120 A

b.- ACTIVE ENERGY METER DOUBLE TARIFF TYPE MKT2

3 phase active energy meter double tariff, direct current input. Display by means of two electromecanic integrating meters in kW.h. The energy will be accumulated by one or the another meter according to the state of the “tariff changing” input provided in the own meter.

<i>Code</i>	<i>type</i>	<i>Current</i>
7 71 078	MKT2-20 - 230 V	Ib = 20 A - Imax = 60 A
7 71 079	MKT2-20 - 400 V	Ib = 20 A - Imax = 60 A
7 71 082	MKT2-40 - 230 V	Ib = 40 A - Imax = 120 A
7 71 083	MKT2-40 - 400 V	Ib = 40 A - Imax = 120 A

Common features:

- All energy meters have **one pulse outputs**. This output permit a remote transmission of the measurement of the kW.h consumed.

Pulses: Open collector type : 5 24 V d.c. / 1..... 30 mA.

Ratio : 10 pulses / kW.h

Duration of pulse : 100 ms

- Current ratio is not necessary user-selected .

- All energy meters operate over two quadrants: **consumed power**.

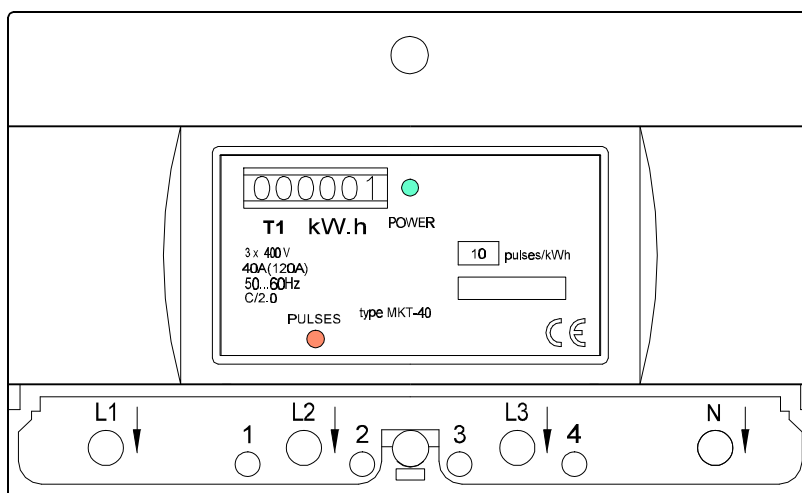

- The meter has a **LEDS** at its frontal cover :

- a green **Led** of "POWER" : indicates that the meter is connect to supply.
- a red **Led** (two for the **MKT2** model) for the metrology control and the energy flow visualisation. Such led blinks each 10 W. h

Particular features of the double tariff meter (MKT2 - xx)

It has an electric input for "tariff change action" (terminal Nr 3 - 4), that set the energy to be accumulated by one or another meter. This is an optocoupled input (4 kV with respect to the electric network).

The first tariff , **T1** , is assigned by voltage lack between those terminals.

Second tariff , **T2** , is selected by applying a 230 Va.c. \pm 10 voltage between those terminals.

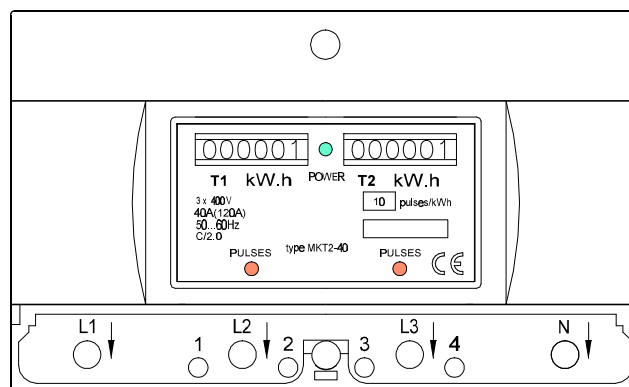

3.- INSTALLATION AND STARTUP



The manual you hold in your hands contains information and warnings that the user should respect in order to guarantee a proper operation of all the instrument functions and keep its safety conditions.

The instrument must not be powered and used until its definitive assembly on the cabinet's door.

Whether the instrument is not used as manufacturer's specifications, the protection of the instrument can be damaged.

When any protection failure is suspected to exist (for example, it presents external visible damages), the instrument must be immediately powered off. In this case contact a qualified service representative.

3.1.- INSTALLATION

Before applying AC power to the, check following points :

- (a) Power supply is taken from own phases **L1-L2 at 400 V a.c. \pm 20 %**
(or **230 V c.a. \pm 20 %** , MKTx-xx-230)



see model : MKTx-xx-400 or MKTx-xx-230 !

- (b) Current input : direct current (see model)
- (c) Frequency : 45 ... 65 Hz
- (d) Instrument burden : < 3 VA
- (e) Operation conditions :
- Operating temperature : -10° C / +45° C
- Humidity : < 75 % R.H. noncondensing

(f) Safety : Designed to meet protection class II as per EN 61010.

Mounting: 

Instrument is to be mounted onto a DIN rail.
All connections keep inside the cabinet.

Note that with the instrument powered on, the terminals could be dangerous to touching and cover opening actions or elements removal may allow accessing dangerous parts. Therefore, the instrument must not be used until this is completely installed.

The instrument must be connected to a power supply circuit protected with gl type (IEC 269) or M type fuses rated between 0.5 and 2 A. This circuit should be provided with an automatic switch (ON / OFF) or any equivalent element to disconnect the instrument from the power supply network. The supply and measuring current - voltage circuits will be both connected through a wire with a minimum cross-section depending of the direct current .

3.2.- ENERGY METER connection terminal

Terminal Nr	Designation	Concept
L1	L1	Phase L1 : Phase 1 voltage input Phase L1 direct current input
L2	L2	Phase L2 : Phase 2 voltage input Phase L2 direct current input
L3	L3	Phase L3 : Phase 3 voltage input Phase L3 direct current input
N	N	Neutral N voltage input
1	+	Pulse output (collector +) for active energy
2	--	Pulse output (COM --) for active energy
3	See model	MKT-xx : Not used MKT2-xx : a.c. voltage input for tariff change
4	See model	MKT-xx : Not used MKT2-xx : a.c. voltage input for tariff change

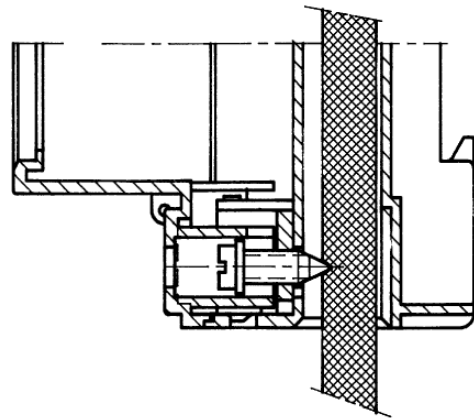
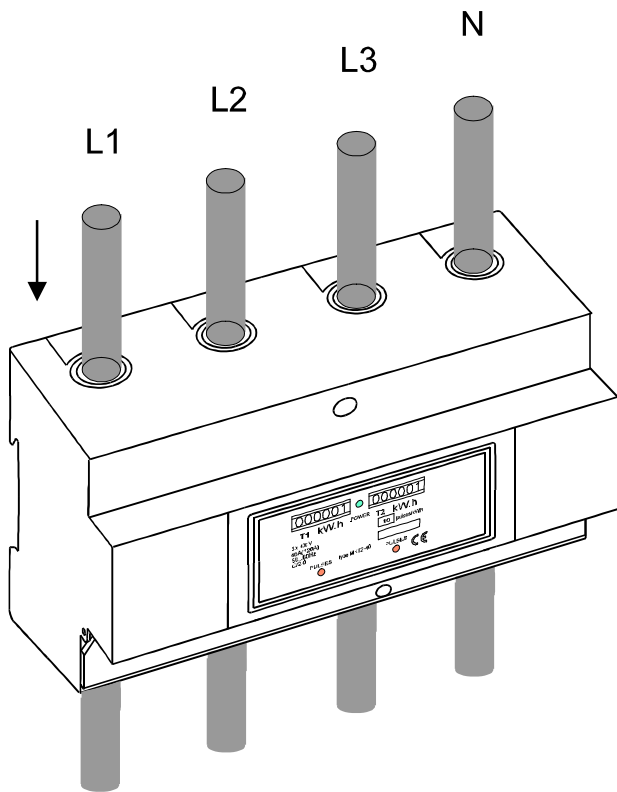

VOLTAGE INPUT VIEW

3.3.- Connection drawing of the THREE PHASE ENERGY METER in a three phase low voltage mains (with or without neutral wire)

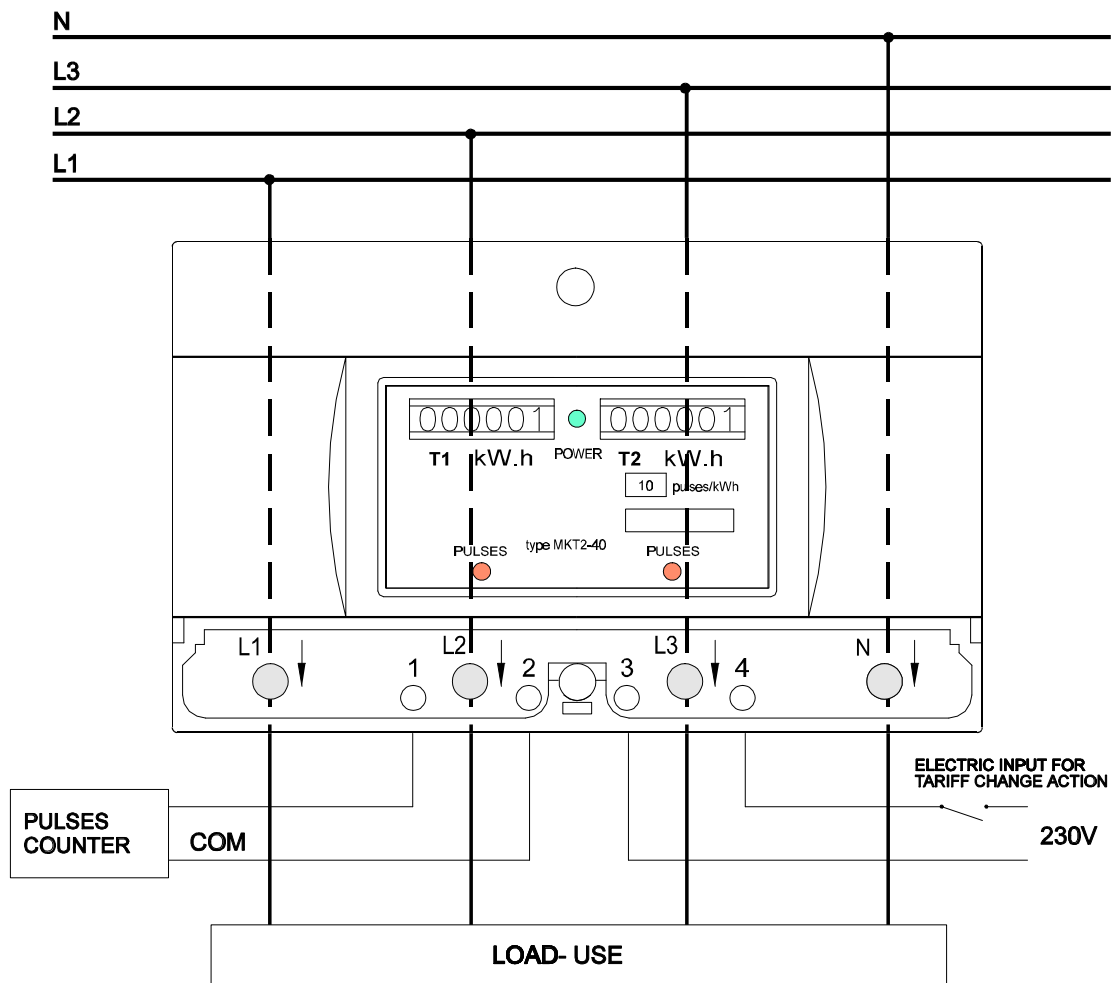

4.- TECHNICAL CHARACTERISTICS

Voltage circuit:

- Rated voltage : 400 V a.c. or 230 V a.c. (see model !)
 - Tolerance : $\pm 20 \%$
 - Consumption : $< 3 \text{ VA} / 2 \text{ W}$
 - Frequency : 45 ... 65 Hz
-

Current circuit:

	<i>MKT-20 & MKT2-20</i>	<i>MKT-40 & MKT2-40</i>
- Rated base current	20 A a.c.	40 A a.c.
- Maximum permanent current	60 A a.c.	120 A a.c.
- Minimum measuring current	0.1 A a.c.	0.2 A a.c.
- Minimum measuring current in the class (5 % Ib)	1 A a.c.	2 A a.c.

- Connection : Direct current
-

Display mode:

- Type : Mechanical rotative (no reset option).
 - Display : **6 digits**
 - Digit height : 4 mm
 - Energy units : kW.h
 - Resolution : 1 kW.h
 - Counting range : 999999 kW.h
-

Accuracy : As per class 2, according to IEC 1036 and EN-61036

Pulse outputs:

- Nr. of outputs : 1
 - Output type : By opto-isolated transistor
 - Nominal voltage : 5... 24 V d.c.
 - Maximum voltage : 55 V d.c.
 - Nominal current : 1...30 mA
 - Maximum current : 50 mA
 - Pulse sequence : 10 pulses / kW.h
 - Pulse duration : 100 ms
 - Isolation : 2,5 kV - 1 min
-

Electric input for "tariff change action - MKT2 :

- Voltage : 230 V a.c. \pm 10
 - Isolation : 2,5 kV - 1 min
-

Standards : IEC - 1036 , EN-61036, EN-61010

Constructive characteristics :

- Case type : Modular, self-extinguishing plastic
- Current cable input : Maximum \varnothing 11 mm
- Voltage connection : Metallic terminals with "posidraft" screws
- Assembly : Fixed onto DIN 46277 (EN 50022) symmetrical rail
- Protection : Built-in relay : IP 41 // Terminals : IP 20

- Dimensions : 140 x 70 x 110 mm (8 modules relay as per DIN 43 880)
- Weight : 0.390 kg

Operating temperature: -10 ° C / +45° C

- DIMENSIONS :

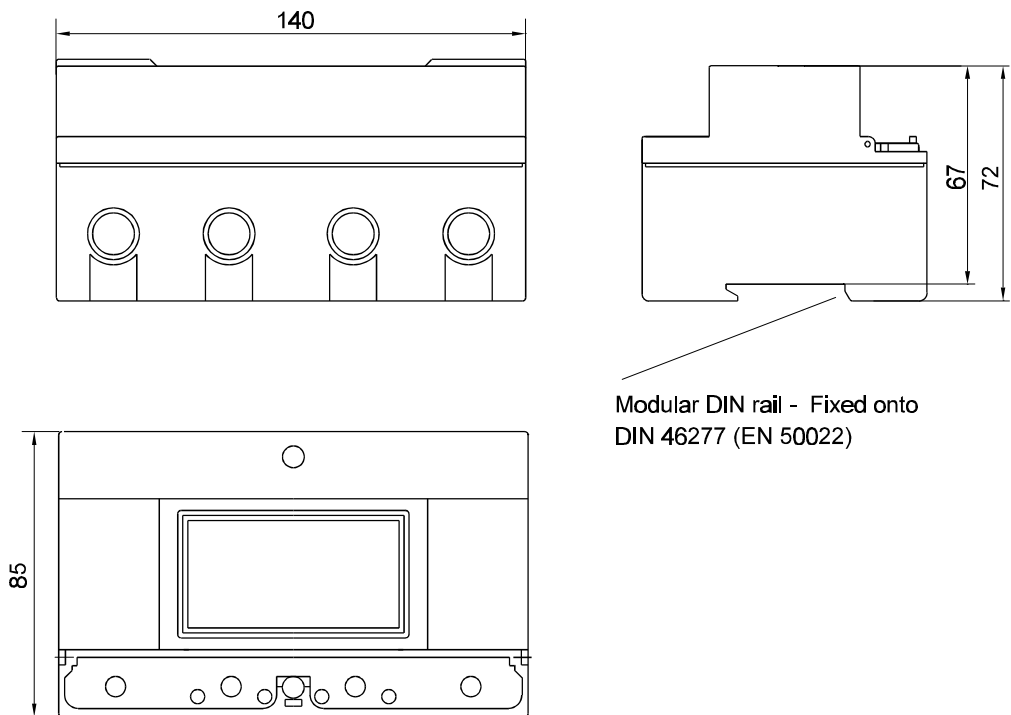

Modular DIN rail - Fixed onto
DIN 46277 (EN 50022)



5.- SAFETY CONSIDERATIONS

All installation specification described in this manual must be carefully observed by the user.

Note that with the instrument powered on, the terminals could be dangerous to touching and cover opening actions or elements removal may allow accessing dangerous parts. This instrument is factory-shipped at proper operation condition.

6.- MAINTENANCE

The MKT & MKT2 ENERGY METERS do not require any special maintenance. No adjustment, maintenance or repairing action should be done over the instrument open and powered and, should those actions are essential, high-qualified operators must perform them.

Before any adjustment, replacement, maintenance or repairing operation is carried out, the instrument must be disconnected from any power supply source.

When any protection failure is suspected to exist, the instrument must be immediately put out of service. The instrument's design allows a quick replacement in case of any failure.

7.- TECHNICAL SERVICE

For any inquiry about the instrument performance or whether any failure happens, contact to CIRCUTOR's technical service.

*CIRCUTOR S.A. - Aftersales Service
c / Lepanto, 49
08223 - TERRASSA - SPAIN
Tel - 34 - 93 745 29 00
fax - 34- 93 745 29 14
e-mail : central@circutor.es*