



Multi-functional electric energy meters

Q.1

Multi-functional electric energy meters

Introduction	3
Q.1 - Multi-functional electric energy meters	
Product selection table	5
CIRWATT A Single-phase active energy meter class 1	7
CIRWATT B Single-phase active energy meter class B and reactive energy class 2	9
CIRWATT C Digital multi-function three-phase meter	11
CIRWATT D High performance, multi-function static meter	14
PLC-800 Concentrator for PLC systems	17
Relation between products and accessories	19

Multi-functional electric energy meters

CIRWATT is a family of combined multi-functional meters that can meet any requirement of an energy metering system, including important aspects, such as quality, accuracy, safety and reliability.

The new metering technologies have allowed **CIRCUTOR** to develop new state-of-the-art equipment, including additional functions for the control and management of metering systems, for example, astronomical clocks, control of the maximum demand, control of programmable power, multi-supply meter (water and gas), meters with photovoltaic applications (two-directional), communications with PLC systems, etc.

The **CIRWATT** family offers a full range of electrical energy meters that are adapted to the type of application. It has the following sub-families:

-
-
-



Definition

In general, electrical consumption meters are devices that meter the consumption of electrical energy in a circuit or electricity service. The market offers electromechanical and electronic meters. Electromechanical meters use parasitic current

and voltage in a disc, influenced by the magnetic fields produced by the turning movement of the needles on a face. Electronic meters use a digital metering mechanism.



Advantage of **CIRWATT** meters:

- Remote management through different channels, for example, through the RS-232 port, RS-485, PLC, etc.
- Readings can be taken with local (Optical Reader), centralised or remote systems.



- There are no mobile parts, so there is no wear.
- There is an internal memory (load curve + billing + events).
- Programmable outputs:
 - Energy impulses
 - Taximeter pulse
 - Active rate
 - Maximum demand alarm
 - Configurable alarms (V, A, W, etc.).
- Lower error diversion throughout the meter's working life.
- Remote loading of the meter's *firmware*. Updates.
- Cost optimisation.
- Greater reading accuracy.
- Optimisation of the space inside meter cabinets (meter + analyzer + clock + taximeter) in a single device.
- Metering of electrical parameters (Voltage, Current, Power Factor, Reactive Energy in 4 quadrants, ...).
- Detection of fraud or manipulation.
- Remote interruption and reinstatement.
- Centralisation of the impulses of other meters (water, gas, ...).
- Variable regulation of the weight of the impulse.
- Integration in home energy management systems. Configurable contracts, rates and seasons.
- Storage in the event log memory:
 - Voltage interruptions
 - Incorrect phase connection
 - Manipulation
- Simple display on the screen:
 - Simple and interesting interface with the parameters metered by the meter.
 - The user can check the partial consumption. The user can check and control his own consumption.
 - Text messages can be sent to the users with notifications or alarms through the alarm outputs integrated in the meter and external GSM/GPRS modem.
 - Billing simulation with the software, using the meter's internal memory.

This section includes the billing meters, but it does not show the sub-metering meters. Submetering meters are shown in section **M3**.

Applications

Applicable to billing

CIRWATT meters are energy meters designed to meter the transfer of energy between frontier points. They are used by utilities companies and other customers. The use of all types of communications means that the information can be recorded by the meters locally or remotely.

Ports

CIRWATT's meters can be used as sub-metering units in wharfs. One of the typical applications of the said units uses PLC communications, since remote communications can be used to centralise the readings in the port's control centre.

The consumption of water can be metered with the impulses emitted by the water meter, connected to the digital inputs of the energy meter, depending on the type of meter. Therefore, automatic

water and energy readings will be taken through the PLC communications.

Photovoltaic installations

There are two possible **CIRWATT**.

The first application involves the placement of the single-phase meter connected to the inverter's output of the solar panel and a totalizer, usually three-phase, located at the frontier point. The second application involves the installation of a three-phase meter in the connection point of the electricity company.

One of the key positions for both applications is the communications with meters. In the first one, the optical system uses PLC communications and in the second one, when there are different installations with various totalizers, the communications can be Ethernet, RS-485 or Modem, thus gathering the data in centralised form.





Submetering installations

Another application used is submetering, not for official billing purposes, but for the metering of energy in the different plots, bungalows, rented apartments, etc.

In these cases, metering can be single or three-phase, with **CIRWATT** meters and PLC communications, centralising all readings in a single **PLC-800** concentrator. This is the way to achieve a more efficient installation in energy terms.

Single-phase meters with circuit breakers can be used for the remote management of the consumption, so that the relay is opened and closed to record / cancel the supply and limit the current, programming the internal relay and controlling the demand.

Product selection table

	Equipment	Active / Reactive Energy Class	Direct / Indirect metering	Voltage	Current	COM1 Communications	COM2 Communications	Load curve 1	Load curve 2	Events	Closing	Inputs / Outputs ***	Page
CIRWATT A		1 / -	Single Direct	230 V 127 V	10(120) A 10(60) A	PLC	-	1 month (60 min) **	-	-	1	•	7
CIRWATT B		B / 2	Single Direct	230 V	10(60) A	PLC	-	3 months (60 min)	-	512	1	•	9
CIRWATT C		1 / 2	Three-Phase Direct / Indirect	3x57/100 V ... 3x230/400 V	5(10) A 10(100) A	PLC RS-232 RS-232 RS-485	- RS-485 Ethernet RS-485	213 days (60 min)	53 days (15 min)	512	64	•	11
CIRWATT D		0,23 / 0,5 0,55 / 1	Three-Phase Indirect	3x57/100 V ... 3x63.5/110 V*	1(2) A 5(10) A	RS-232	RS-485 Ethernet	213 days (60 min)	53 days (15 min)	512	64	•	14
PLC-800		-	-	3x230/400 V ... 3x127/220 V	-	PLC	Ethernet GSMGPRS	•	-	•	•	-	17

(*) For other voltages, please ask

(**) Only models with PLC

(***) See specific catalogue

CIRWATT A

Single-phase active energy meter, Class 1



Description

CIRWATT A is a single-phase, digital multi-function meter, Class 1, for the metering of active energy.

CIRWATT A complies with the existing regulations applicable to electronic meters and it has an autonomous data retention system that avoids them from being lost when there is an interruption in the power supply. Likewise, it can be read through the screen (even when there is no power supply) and through the optical port (protocol IEC-61107).

There is also a type with PLC (Power Line Carrier) communications and an internal circuit breaker for the management of the demand, with an innovating reclosure system.

Application

It has been specially designed for installations where electromechanical meters do not satisfy the current needs, particularly those that require a single-phase meter with a billing system.

There are three main types of A-meters: multi-rate meter; for photovoltaic applications and meter with PLC communications.

Features

Power supply	Self-powered
Nominal voltage	127 V or 230 V (depending on the type)
Consumption	< 2 W / 10 V·A
Frequency	50 / 60 Hz, no differentiation
Operating temperature	- 20 °C ... + 60 °C
Voltage metering	
Connection	Symmetrical or asymmetrical
Reference voltages	127 V or 230 V (depending on the type)
Frequency	Automatic (50 / 60 Hz, with no differentiation)
Current metering	
Currents (I_n)	5 A Direct (Maximum 60 A) 10 A Direct (Maximum 120 A)
Maximum current	12 I_n
Accuracy	
Active Energy	Class 1.0 (IEC 62053-21)
Calculation and processing	
Microprocessor	Based on DSP
Converter	16 bits
Memory	
Data	RAM type, stored by Lithium battery
Setup and events	Non-volatile memory of the FLASH type
Battery	
Type	Lithium
Working Life	> 10 years
Clock	
Type	Grid frequency quartz oscillator
Drift	< 0.5 s/day at 25 °C
Digital outputs	Potential-free
Type	Optocoupler (24 V)
Relay outputs	230 V - 10 A
Type	Mechanical relay
LED Outputs	
Maximum rate	1000 impulses / kW·h
Safety	Category III (110 V) in accordance with EN-61010
Build features	
Enclosure	In compliance with DIN 43859
Dimensions	In compliance with DIN 43857
Degree of protection	IP 51
Optical reader	IEC-61107 for local access

CIRWATT A

Single-phase active energy meter, Class 1

Dimensions

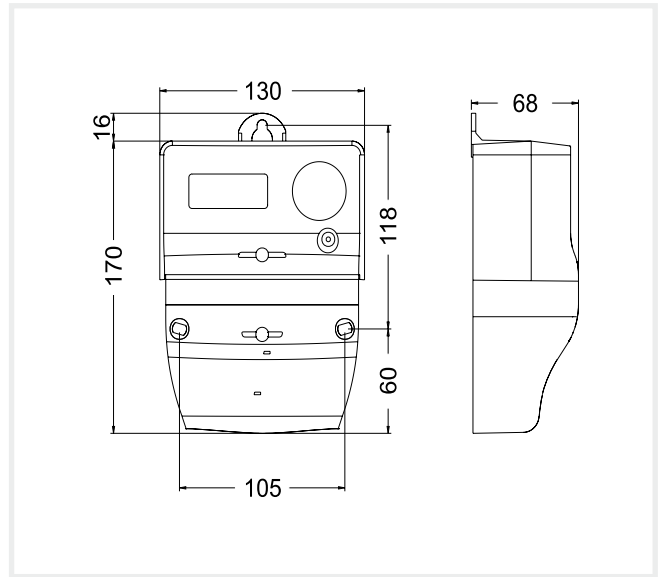

Standards

EN 62053-21	Standards for static, active energy meters for alternating current, Class 1
EN 55022	Driven emissions: Class B / Radiated emissions: Class B
EN 61000-4-6	Immunity to RF fields coupled to cables (common mode): 10 V
EN 61000-4-8	Immunity to magnetic fields and grid frequency: 30 A/m

References

Metering voltage 230 Vac	Current metering range (A)	Hourly discrimination	Quadrants	Relay outputs	Impulse outputs	Impulse inputs	Communication	Internal Circuit breaker	Type
• 10 (120)	DH1	2			1				CIRWATT A - 210-ED3-01A-00
• 10 (120)	DH0	2	2						CIRWATT A - 210-ED3-01A-00
• 5 (60)	DH1	2			1				CIRWATT A - 210-ED4-01A-00
• 5 (60)	DH0	2	1						CIRWATT A - 210-ED4-01A-00
• 10 (120)	DH1	4			1				CIRWATT A - 210-ED3-01A-10
• 10 (120)	DH1	2			1		PLC A		CIRWATT A - 210-ED3-41A-00
• 10 (120)	DH1	2				2	PLC A		CIRWATT A - 210-ED3-44A-00
• 5 (60)	DH1	2			1		PLC A	•	CIRWATT A - 210-ED3-41A-02
• 10 (120)	DH1	4			1		PLC A		CIRWATT A - 210-ED3-41A-00

Connections

With one or two outputs of the mechanical relay

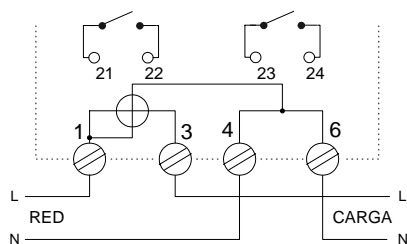

With a digital energy impulse output

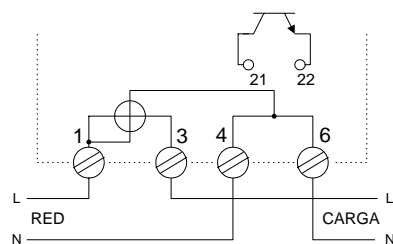

CIRWATT B

Single-phase active energy meter, Class B and reactive, Class 2



Description

CIRWATT B is a multi-function digital single-phase meter, Class B, for the metering of active energy and Class 2 for the metering of reactive energy.

The meter complies with the current European legislation related to energy meters (MID) EN 50470-1 and EN 50470-3, which approves the installation of these meters in any country of the European Union.

It includes PLC (Power Line Carrier) communications through the power grid and an optical port. Both types of communications use the EC-870-5-102 protocol. It also includes an analyzer that can store up to 3 months of hourly records of the 6 types of energy. Likewise, data can be read when there is no voltage.

It includes a circuit breaker, which can be used by the user to control the supply demand with a reliable and safe approach.

Application

The main application of the **CIRWATT B** meter is the metering of active and reactive energy for billing purposes, whenever a meter with high performance features is required at an optimised cost. PLC communications can be used for the remote download of all data recorded by the meter through a **PLC800** concentrator.

The circuit breaker integrated in the meter can be used to manage the supply remotely, opening/closing the circuit breaker and programming the hired power above a value that will activate the circuit breaker, opening it and reclosing it to guarantee the safety for the final user.

Features

Power supply	Self-powered
Nominal voltage	230 V
Tolerance	± 20 %
Consumption	< 2 W / 10 V·A
Frequency	50 / 60 Hz, no differentiation
Operating temperature	- 25 °C ... + 70 °C
Voltage metering	
Connection	Asymmetrical
Reference voltages	230 V
Frequency	Automatic (50 / 60 Hz, with no differentiation)
Self-consumption of the voltage circuit	< 2 W / 10 V·A
Current metering	
Currents (i_n)	10 A Direct (Maximum 60 A)
Maximum current	60 A
Start-up current	< 10 mA
Self-consumption of the voltage circuit	0.2 V·A at 10 A
Accuracy	
Active Energy	Class B (50470)
Reactive Energy	Class 2.0 (IEC 62053-21)
Calculation and processing	
Microprocessor	Risc 16 bits
Converter	16 bits
Memory	
Data	RAM type, stored by Lithium battery
Setup and events	Non-volatile memory of the FLASH type
Battery	Lithium
Working Life	> 15 years
Clock	
Type	Self-compensated quartz crystal oscillator
Drift	< 0.5 s/day at 25 °C
Billing output	
Type	Relay
Operational	Selection of the activation rate
Features	Max. 250 Vac 5 A with connection to the neutral potential when activated
Build features	
Enclosure	In compliance with DIN 43859
Dimensions	In compliance with DIN 43857
Degree of protection	IP 53

CIRWATT B

Single-phase active energy meter, Class B and reactive, Class 2



Dimensions

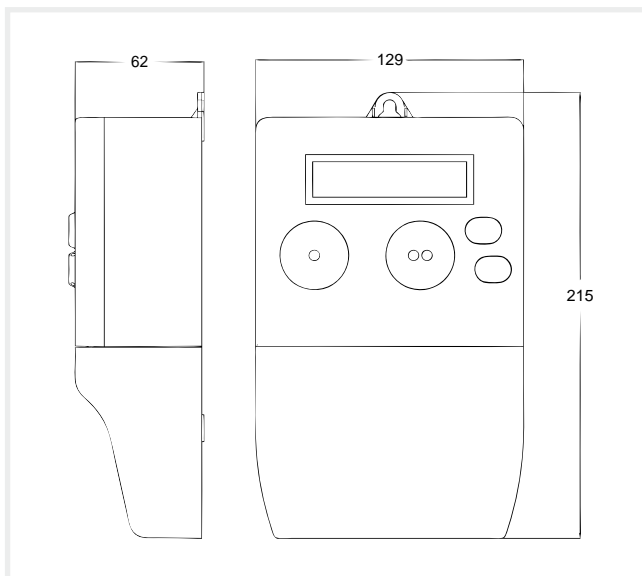

Features

Optical port	
Hardware	EN 62056
Speed	9600 baud
CIRCUTOR version Protocol	REE Protocol, based on IEC 870
PLC	
Protocol	CIRCUTOR - Renesas
Modulation system	DCSK with repeater system
Consumption	1.2 W - 12 V·A
Tampering detector	
Activation	Manipulation of the meter or connections
Delay	Activation is delayed 72 hours to facilitate the installation
Insulation	
Alternating voltage	4 kV RMS 50 Hz during 1 minute
Over-impulse	
1.2/50 ms - 0 W - strong impedance	6 kV at 60 °C and 240 °C with positive and negative polarity

Standards

EN 50470-1 and EN 50470-3
Standards for static, active energy meters for alternating current, Class B
EN 55022
Driven emissions: Class B Radiated emissions: Class B
EN 61000-4-11
Gaps or brief voltage interruptions
EN 61000-4-2
Electrostatic discharges
EN 61000-4-3
Radio-frequency electromagnetic fields
EN 61000-4-4
Electrical transient bursts
EN 61000-4-5
Shockwave
EN 61000-4-6
Alterations driven and induced by radio-frequency fields
EN 61000-4-8
Magnetic fields in the grid frequency with an external origin

References

Metering voltage	Current metering range (A)	Hourly discrimination	Quadrants	Relay outputs	Impulse outputs	Impulse inputs	Communication	Internal Circuit breaker	Type
230 Vac	10 (60)	DH1	4	2			PLC A		CIRWATT B - 212-ES4-43B-12
	10 (60)	DH0	4	2			PLC A		CIRWATT B - 212-ED4-43B-12

Connections

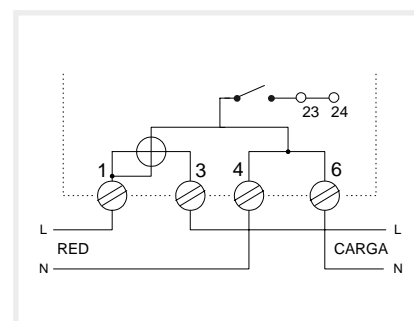

CIRWATT C

Digital multi-function three-phase meter



Description

Digital multi-function three-phase meter, with 2 or 4 quadrants, with type-1 accuracy in active energy and type-2 accuracy in reactive energy, direct or indirect metering, with the possibility of programming up to 3 contracts.

In accordance with the demands and needs of the electricity market, **CIRCUTOR** has included 2 communications ports (on demand), respecting the IEC and MODBUS communications protocols. It is committed to future technologies, adapting a range of Type C meters to the new communications system, PLC.

The main display shows the following visual indicators in standby mode:

- Energy direction
- Reactive capacitive / reactive
- Quadrant being used
- Phases activated and their direction
- Active rate per contract
- The meter also has 3 alarms to indicate the status of the contact or the installation: critical, non-critical and battery.

Application

CIRWATT C is ideal for LV and MV power supplies up to 450 kW.

Special 4Q meter for FV plants, with an endless number of communications options.

Features

Power supply circuit	Self-powered
Nominal voltage	Multi-range, from 3x57.7/100 V to 3x230/400 Vac
Tolerance	± 20 %
Consumption	< 2 W / 10 V·A
Frequency	50 ... 60 Hz
Operating temperature	- 20 °C ... + 60 °C
Metering circuit	
Connection	3 or 4 wires from the same unit
Reference voltages	Multi-range, from 3x57.7/100 V to 3x230/400 Vac
Frequency	50 ... 60 Hz
Current circuit	
Nominal base currents	.../5 or .../1 A (indirect metering; 10 A (direct metering)
Maximum current	10 or 2 A ($2 \times I_n$) (indirect metering); 100 A ($10 \times I_n$) (direct metering)
Accuracy	
Active Energy	Class 1 (IEC 61036)
Reactive Energy	Class 1 (IEC 61268)
Data memory	FLASH (non-volatile memory)
Capacity	Events: 512 records / Billing closing: 64 / Load curve: 213 days / 2nd programmable load curve: 5,120 records
Clock maintenance battery	Lithium
Working Life	10 years (50% load)
Operation with no battery or voltage	Maximum 24 hours
Clock	
Type	Quartz oscillator / grid synchronism (adjustable by the programmer)
Quartz oscillator drift	< 0.5 s/day at 25 °C
Digital inputs (on demand)	4 inputs (60...300 Vac)
Digital outputs (on demand)	3 mechanical relay outputs (up to 400 Vac) optoMOS
Verification LED output	
Rate	20 000 impulses / kW·h or kvar·h, in terms of secondary values (indirect metering); 1 000 impulses / kW·h (direct metering)
Communications	
Optical interface	IEC-61107
COM 1	RS-232 / RS-485 / Ethernet / PLC (depending type)
Protocols	IEC-870-5-102, IEC-61107
Build features	
Enclosure	In compliance with DIN 43859
Weight	1.9 kg

CIRWATT C

Digital multi-function three-phase meter



Dimensions

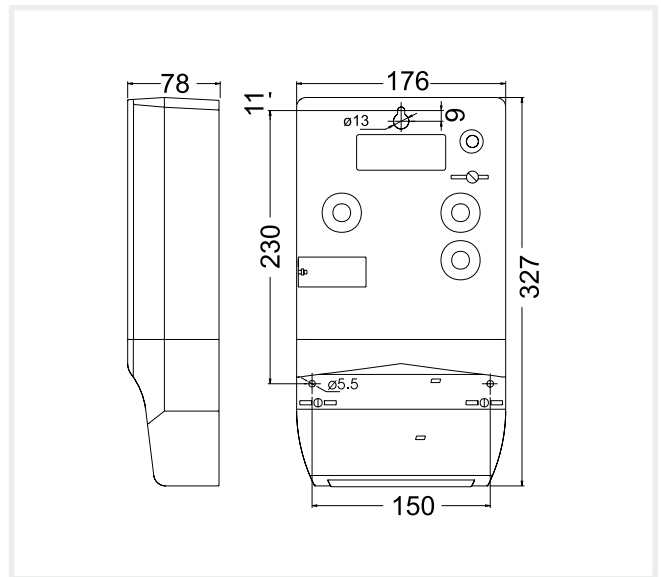

Standards

IEC60687	Static active energy meters for ac, Class 0.5S, 0.2S
IEC61036	Static active energy meters for ac, Class 1
IEC61268	Static reactive energy meters for ac, Class 1 and 2
EN -50081-1	Residential emissions
EN -50082-2	Industrial immunity
EN 55022	Driven emissions: Class B / Radiated emissions: Class B
EN 61000-4-6	Immunity to RF fields coupled to cables (common mode): 10 V
EN 61000-4-8	Immunity to magnetic fields and grid frequency: 30 A/m

Connections

3 / 4 Wire Connection (LV)

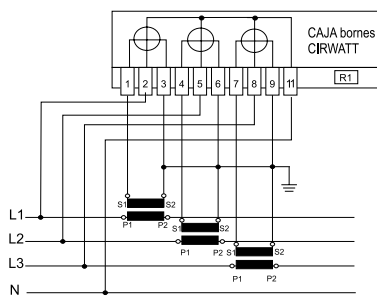

3 Wire Connection (MV)

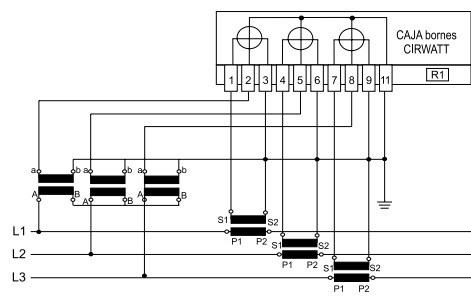

3 Wire Connection (MV)

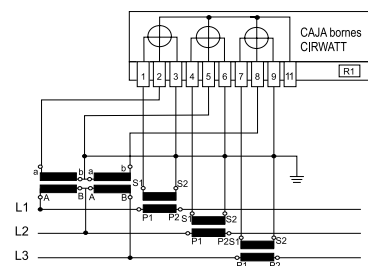

Direct metering

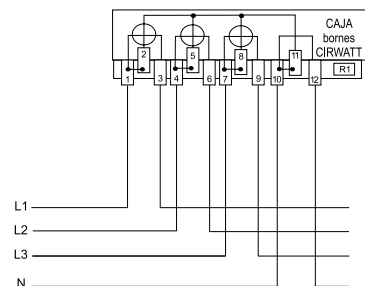

CIRWATT C

Digital multi-function three-phase meter



References

Consumer	Class	Quadrants	Metering range V	Metering range A	Relay Input / Output	Metering inputs	COM1 Communications	COM2 Communications	Type
STANDARD									
4	1	2	3x57/110 V at 3x230/400 V	10(100) A	-	-	RS232		CIRWATT C 410-UD1C-10C
3	1	2	3x57/110 V at 3x230/400 V	... / 5 A	-	-	RS232		CIRWATT C 410-UT5C-10C
4	1	2	3x57/110 V at 3x230/400 V	10(100) A	-	-	RS485		CIRWATT C 410-UD1C-20C
3	1	2	3x57/110 V at 3x230/400 V	... / 5 A	-	-	RS485		CIRWATT C 410-UT5C-20C
Indicate: Distribution, area, hourly discrimination and current transformer ratio, if applicable									
Three-phase meters with additional features									
INPUTS AND OUTPUTS									
3	1	2	3x57/110 V at 3x230/400 V	... / 5 A	4/3	-	RS232		CIRWATT C 410-UT5C-14C
3	1	2	3x57/110 V at 3x230/400 V	... / 5 A	4/3	-	RS232		CIRWATT C 410-UT5C-15C
3	1	2	3x57/110 V at 3x230/400 V	... / 5 A	4/3	-	RS232		CIRWATT C 410-UT5C-24C
3	1	2	3x57/110 V at 3x230/400 V	... / 5 A	4/3	-	RS232		CIRWATT C 410-UT5C-25C
PHOTOVOLTAIC APPLICATIONS (4 quadrants)									
3	1	4	3x57/110 V at 3x230/400 V	... / 5 A	-	-	RS232		CIRWATT C 410-UT5C-10C
4	1	4	3x57/110 V at 3x230/400 V	10(100) A	-	-	RS232		CIRWATT C 410-UD1C-10C
ETHERNET COMMUNICATIONS									
3	1	2	3x57/110 V at 3x230/400 V	... / 5 A	-	-	Ether.		CIRWATT C 410-UT5C-30C
4	1	2	3x57/110 V at 3x230/400 V	10(100) A	-	-	Ether.		CIRWATT C 410-UD1C-30C
MAXIMUM DEMAND CONTROL									
3	1	2	3x57/110 V at 3x230/400 V	... / 5 A	4/3	-	RS232		CIRWATT C 410-UT5C-15C
4	1	2	3x57/110 V at 3x230/400 V	10(100) A	4/3	-	RS232		CIRWATT C 410-UD1C-15C
3	1	2	3x57/110 V at 3x230/400 V	... / 5 A	4/3	-	RS485		CIRWATT C 410-UT5C-25C
4	1	2	3x57/110 V at 3x230/400 V	10(100) A	4/3	-	RS485		CIRWATT C 410-UD1C-25C
ASTRONOMICAL CLOCK									
3	1	2	3x57/110 V at 3x230/400 V	... / 5 A	4/3	-	RS232		CIRWATT C-AS 410-UT5C-15C
4	1	2	3x57/110 V at 3x230/400 V	10(100) A	4/3	-	RS232		CIRWATT C-AS 410-UD1C-15C
3	1	2	3x57/110 V at 3x230/400 V	... / 5 A	4/3	-	RS485		CIRWATT C-AS 410-UT5C-25C
4	1	2	3x57/110 V at 3x230/400 V	10(100) A	4/3	-	RS485		CIRWATT C-AS 410-UD1C-25C
PLC COMMUNICATIONS									
3	1	2	3x230/400 V	... / 5 A	-	-	PLC		CIRWATT C 410-QT5C-40C
4/5	1	2	3x230/400 V	10(100) A	-	-	PLC		CIRWATT C 410-QD1C-40C
Meters with inputs (water and gas) with PLC communications									
3	1	2	3x230/400 V	... / 5 A	-	2	PLC		CIRWATT C 410-QT5C-46C
4/5	1	2	3x230/400 V	10(100) A	-	2	PLC		CIRWATT C 410-QD1C-46C
Meters with 2 communications ports									
3	1	2	3x57/110 V at 3x230/400 V	... / 5 A	-	-	RS485	RS485	CIRWATT C 410-UT5C-80C
4	1	2	3x57/110 V at 3x230/400 V	10(100) A	-	-	RS485	RS485	CIRWATT C 410-UD1C-80C
3	1	2	3x57/110 V at 3x230/400 V	... / 5 A	-	-	RS232	RS485	CIRWATT C 410-UT5C-90C
4	1	2	3x57/110 V at 3x230/400 V	10(100) A	-	-	RS232	RS485	CIRWATT C 410-UD1C-90C

FOR OTHER CONFIGURATIONS (inputs, outputs and other communications), PLEASE ASK

CIRWATT D

High-performance, multi-function static meter



Description

High-accuracy meter, metering in 4 quadrants and offering the maximum programming and communications flexibility, in order to cater for any type of requirement. The best option for large-scale consumers. The meter has an LCD display with 3 lines, where all parameters are displayed on 2 buttons.

The main display shows the following visual indicators in standby mode:

- Energy direction
- Reactive capacitive / reactive
- Quadrant being used
- Phases activated and their direction
- Active rate per contract

The meter also has 3 alarms to indicate the status of the contact or the installation: critical, non-critical and battery.

Application

It has been specially designed for installations that require: billing by contract, dual load profile or various remote metering systems operating in parallel. It adapts to the needs of each client, thanks to the many different communications ports and protocols.

- RS-232 - RS-232
- RS-232 - RS-485
- RS-232 - ETHERNET

Features

Power supply circuit	Self-powered
Nominal voltage	Depending on the type
Consumption	< 2 W / 10 V·A
Frequency	50 or 60 Hz (depending on the type)
Operating temperature	- 20 °C ... + 60 °C
Metering circuit	
Connection	3 or 4 wires from the same unit
Reference voltages	3x63.5/110 V, 3x110/190 V, 3x127/220 V, 3x230/400 V (depending on the type)
Frequency	50 or 60 Hz
Current circuit	
Nominal base currents	.../5 or .../1 A (indirect reading)
Maximum current	10 or 2 A (2 x I _n) (indirect reading)
Accuracy	
Active Energy	Class 1 (IEC 61036); Class 0.2S or 0.5S (IEC 60687)
Reactive Energy	Class 0,5 or 1 (IEC 61268); Class 2 (61268)
Data memory	FLASH (non-volatile memory)
Capacity	Events: 512 records / Billing closing: 64 / Load curve: 213 days / 2nd programmable load curve: 5,120 records
Clock maintenance battery	Lithium
Working Life	10 years (50% load)
Operation with no battery or voltage	Maximum 24 hours
Clock	
Type	Grid frequency / quartz oscillator
Quartz oscillator drift	< 0.5 s/day at 25 °C
Digital inputs (on demand)	3 inputs (60...300 Vac)
Digital outputs (on demand)	3 mechanical relay outputs (up to 400 Vac) optoMOS (depending on the type)
Verification LED output	
Rate	20 000 impulses / kW·h or kvar·h, in terms of secondary values
Communications	
Optical interface	IEC-61107 - Reading / Programming
COM 1	RS-232 - Reading / Programming
COM 2	RS-232 / RS-485 - Reading
Protocols	IEC-870-5-102, Modbus-RTU, IEC-61107
Build features	
Enclosure	In compliance with DIN 43859
Weight	2.2 kg

CIRWATT D

High-performance, multi-function static meter

Dimensions

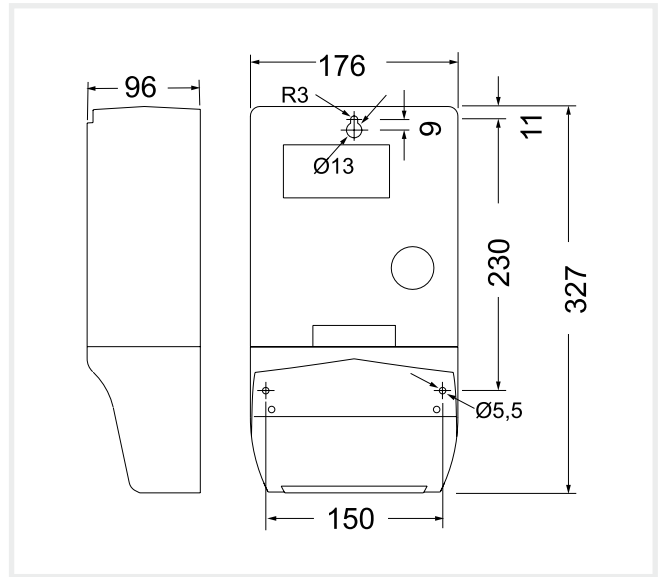

Standards

IEC 60687	Static active energy meters for ac, Class 0.5S, 0.2S
IEC 61036	Static active energy meters for ac, Class 1
IEC 61268	Static reactive energy meters for ac, Class 1 and 2
EN-50081-1	Residential emissions
EN-50082-2	Industrial immunity
EN 55022	Driven emissions: Class B / Radiated emissions: Class B
EN 61000-4-6	Immunity to RF fields coupled to cables (common mode): 10 V
EN 61000-4-8	Immunity to magnetic fields and grid frequency: 30 A/m

Connections

3 / 4 Wire Connection (LV)

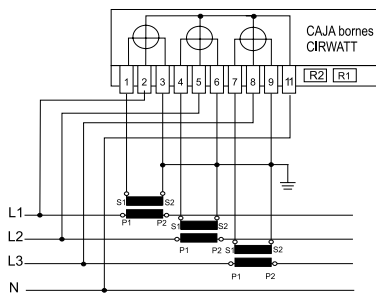

3 Wire Connection (MV)

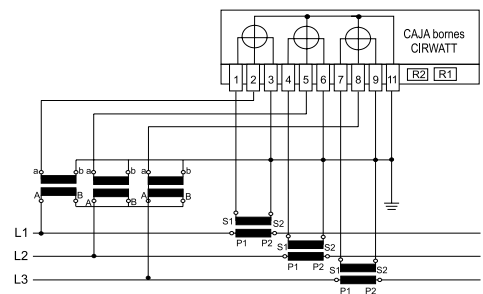

3 Wire Connection (MV)

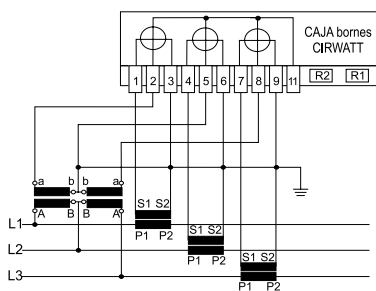

3 ARON Wire Connection (MV)

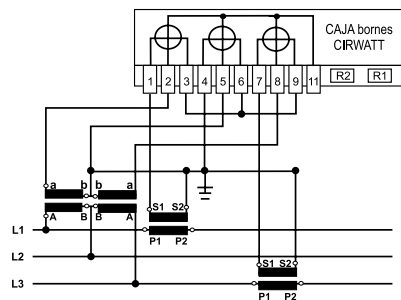

CIRWATT D

High-performance, multi-function static meter



References

Consumer type	Class	Quadrants	Metering range V	Metering range A	OptoMOS Input / Output	Relay Input / Output	COM1	COM2	TYPE
STANDARD									
2	0.5S	4	3x63.5/110 V	... / 5 A	-	-	RS232	RS232	CIRWATT D 405-MT5A-10D
2	0.5S	4	3x63.5/110 V	... / 5 A	-	-	RS232	RS485	CIRWATT D 405-MT5A-20D
2	0.5S	4	3x63.5/110 V	... / 5 A	-	3/4	RS232	RS232	CIRWATT D 405-MT5A-15D
2	0.5S	4	3x63.5/110 V	... / 5 A	3/4	-	RS232	RS232	CIRWATT D 405-MT5A-14D
2	0.5S	4	3x63.5/110 V	... / 5 A	-	3/4	RS232	RS485	CIRWATT D 405-MT5A-25D
2	0.5S	4	3x63.5/110 V	... / 5 A	3/4	-	RS232	RS485	CIRWATT D 405-MT5A-24D
1	0.2S	4	3x63.5/110 V	... / 5 A	-	-	RS232	RS232	CIRWATT D 402-MT5A-10D
1	0.2S	4	3x63.5/110 V	... / 5 A	-	-	RS232	RS485	CIRWATT D 402-MT5A-20D
1	0.2S	4	3x63.5/110 V	... / 5 A	-	3/4	RS232	RS232	CIRWATT D 402-MT5A-15D
1	0.2S	4	3x63.5/110 V	... / 5 A	3/4	-	RS232	RS232	CIRWATT D 402-MT5A-14D
1	0.2S	4	3x63.5/110 V	... / 5 A	-	3/4	RS232	RS485	CIRWATT D 402-MT5A-25D
1	0.2S	4	3x63.5/110 V	... / 5 A	3/4	-	RS232	RS485	CIRWATT D 402-MT5A-24D
Indicate: Distribution, area, hourly discrimination and current transformer ratio, if applicable.									
Three-phase meters with additional features									
ETHERNET COMMUNICATIONS									
2	0.5S	4	3x63.5/110 V	... / 5 A	-	-	RS232	Ether.	CIRWATT D 405-MT5A-30D
1	0.2S	4	3x63.5/110 V	... / 5 A			RS232	Ether.	CIRWATT D 402-MT5A-30D

FOR OTHER CONFIGURATIONS (inputs, outputs and other communications), PLEASE ASK

PLC-800

Concentrator for PLC systems



Description

The product proposed by **CIRCUTOR, S.A** as the lead device for reading energy meters with PLC communications - either three-phase or single-phase - connected to the low-voltage mains, and normally located within a substation - either interior or exterior - is the **PLC-800** concentrator.

This device can connect to different communications systems, such as PLC (Power Line Carrier), Ethernet, GSM and GPRS. These communications offer different options to the PLC800 concentrator, so that it can communicate with the concentrator, either with the purpose of configuring the concentrator or to send the information automatically to a server.

Application

The main objective is to gather the data from the meters through PLC communications, i.e., through the power grid.

The installation of the **PLC-800** must be the header of the distribution line, near the medium voltage transformer, connected to the low voltage line. The unit has a colour screen, which can be used to configure the different communication parameters and data related to the files stored, as well as to display a list of the meters that are connected correctly; or with a deviation of more than 6 hours, or a difference of 24 h, identified by different colours.

Features

General	
Reference voltage	3x230/400 V or 3x127/220 (3/4 wires)
Operating limit voltage	440 V during 6 hours
Reference frequency	50 Hz
Minimum temperature	- 25 °C
Maximum temperature	+ 70 °C, 95 % of relative humidity
IP protection	IP 51
Clock	Automatic daily synchronisation
Memory	Type SD (512 Mb) 1,000 meters 20 years without maintenance
Communications	1 Ethernet port 2 USB ports 1 GSM/GPRS modem port
Display	Colour LCD
Buttons	2 buttons for navigating through screens

It is a *Plug&Play* system, so that the meters are detected automatically by the concentrator when they are installed in the grid. The concentrator then starts to download all data in the memory of the meters, including energy load curves, events and billing closing, up to the current date. On the other hand, the **PLC-800** uses different routines that, for example, send the data downloaded from the meters every day to an FTP server, adding the new file with the daily energy summary of all meters

PLC-800

Concentrator for PLC systems

Dimensions

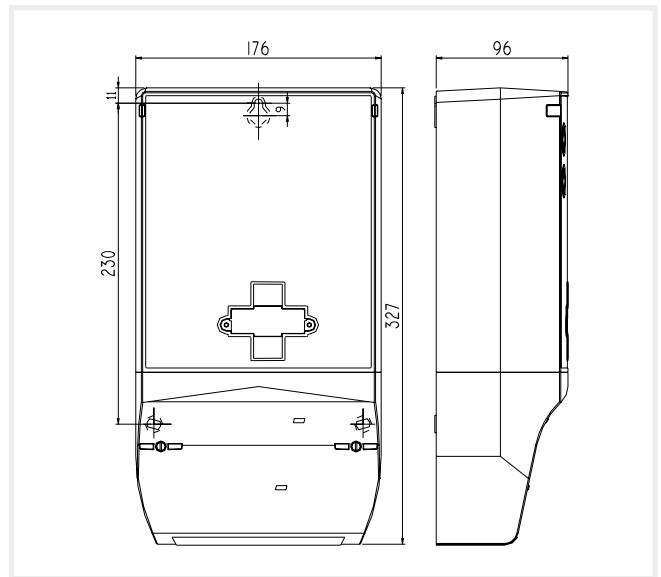

References

Power supply voltage 127 ... 230 Vac	PLC Communications band	Metering voltage 3x230/400 V	Number of PLC Communications inputs	GSM/GPRS Modem	USB Ports	Ethernet Port	Type	Code
•	A	•	1	•	2	1	PLC800-U-1-2M00-12-0	Q45210
•	B	•	1	•	2	1	PLC800-U-1-4M00-12-0	Q45310
•	A	•	2	•	2	1	PLC800-U-1-2M2M-12-0	Q45211

Connections

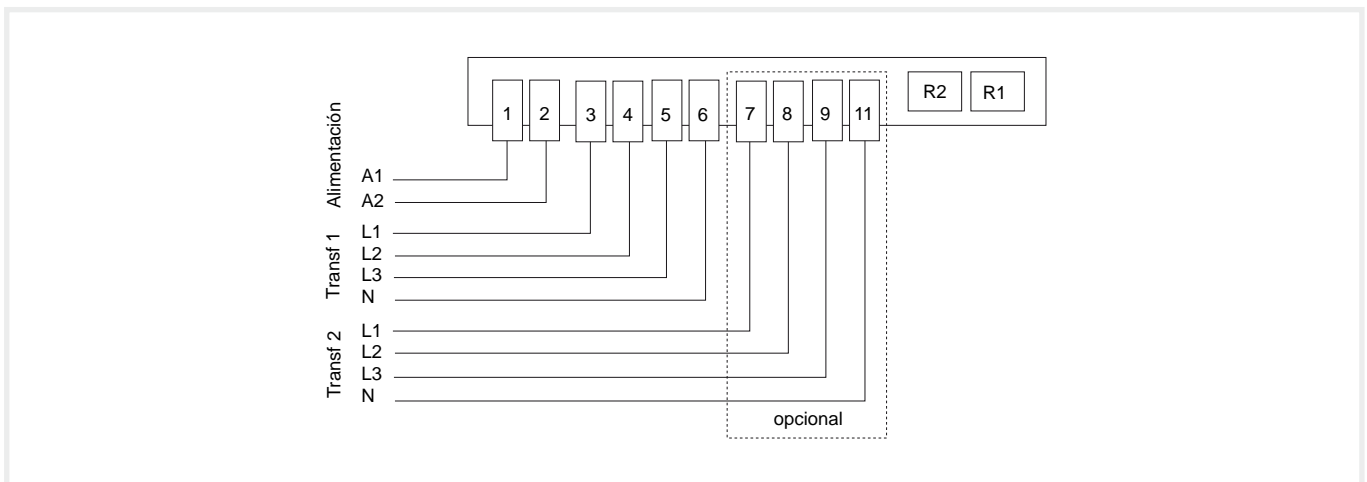

Relation between products and accessories

		Converters	TRMC	Modem	LOC	LM4-PLC	Software
							
		Communications converters	Current transformers	GSM, RTC, protector	Optical reader	Impulse concentrator	Management and control Software
		See M.5	See Q.3	See Q.3	See Q.3	See Q.3	See Q.3
CIRWATT A		-	-	-	•	•	•
CIRWATT B		-	-	-	•	•	•
CIRWATT C		•	•	•	•	•	•
CIRWATT D		•	•	•	•	•	•
PLC-800		-	-	-	-	•	•

