



**OVERCURRENT / GROUND FAULT
PROTECTION RELAY**

MPRB-99-1.0-GF

(Code 512 191)

INSTRUCTION MANUAL

(M 981 222 / 00 A)

© CIRCUTOR S.A.

1.- GENERAL	3
2.- MAIN CHARACTERISTICS	3
3.- FUNCTIONING DESCRIPTION OF THE RELAY	3
3.1.- Wiring instructions	3
3.2.- Tripping curve selection.....	4
3.3.- Current setting (i_n).....	4
3.4.- Ground fault trip point setting ($I_{o>}/I_n$)	5
3.5.- Ground fault time delay setting ($t_{0>}(s)$)	5
3.6.- Ground Fault setting limits	5
3.7.- Display indicators	7
3.8.- External trip	7
3.9.- Test of the measurement system	7
4.- INTERNAL ELECTRONIC SYSTEM.....	8
4.1.- Signal acquisition and processing.....	8
4.2.- Trip	8
5.- TECHNICAL DATA	9
6.- ANNEX	
- Curve #1	10
- Curve #2	11
- Curve #3.....	12
- Curve #4	13
- Curve #5.....	14
- Wiring and technical instruction sticker (fig. 6)	15
- Front side (fig. 7).....	15
- Block Diagram (fig. 8)	16
- Dimension of MPRB-99-1.0-GF relay (fig.9)	17
- Dimension/wiring of MPTA 96-14-90 trans. (fig. 10).....	18
- Dimension/wiring of MPTA 96-117-737 trans. (fig. 11).....	19

1.- GENERAL

The relay (**MPRB-99-1.0-GF**) including a set of transformers typed (**MPTA 96-14-90**) or (**MPTA 96-117-737**) are the basic blocks to build an overcurrent / *ground fault* three pole protection system, for transformers or half voltage distribution stations. With a sequence of tripping pulses over a switching device or over an electric cut system, it is possible to interrupt the supply system. Those pulses are generated by the relay when an overcurrent / *ground fault* is present for a period of time. Protection degree IP 67 of the relay and transformers resin containers, provide high level of functionality over adverse climatic situations.

2.- MAIN CHARACTERISTICS

- Equipment including microprocessor technology.
- 5 tripping curves.
- 4 starting overcurrent.
- Overcurrent calculations in RMS for hardly the whole overcurrent range.
- Overcurrent measurements from $1I_n$ up to $11.82 I_n$.
- 16 *Ground fault current setting from 0.1 to 1.2 $I_{o>/I_n}$* .
- 15 *Ground fault delay time setting from 50 ms to 120 s*.
- *Possibility of Ground fault function cancellation*.
- The display shows tripping cause (**Trip Ext.**), (**Trip I_N**) and (**Trip $I_{o>/I_n}$**).
- The display shows time tripping starting (**$I_N>$** , **$I_{o>/I_n}$**).
- The display shows external power supply input (**POWER**).
- The display shows and memorises trip indicator for a time exceeding 48h.
- It is NO necessary auxiliary power supply.
- External trip for voltage of 230 Vac.
- Delay in external trip to avoid unexpected tripping.
- Possibility of working with 230 Vac. auxiliary power supply (warranty external trip).
- While current through transformers is not interrupted, tripping pulses keep on.
- Working temperature from -40°C up to 85°C .
- Standards for protection relays IEC 255.
- Other standards related EMC (IEC 801-2, IEC 801-3, IEC 801-4).
- Protection degree IP 67.
- Test coil at the same transformer to test the equipment.
- Galvanic isolation across supply transformer and current measurement transformer.

3.- FUNCTIONING DESCRIPTION OF THE RELAY

3.1.- Wiring instructions. (Figure 6)

Measurement transformers supply enough energy to the relay to satisfactory work as a protection device. Transformers must be connected to inputs **(7-8)**, **(9-10)** and **(11-12)**.

Tripping coil will be connected to outputs **(4-5)**. When external tripping possibility is required it will be done through connections **(1-2)** when primary current is greater than 70% that of the minimum range value of (**I_{na}**) corresponding to transformer connections **(14.4 - 41.1 - 117.4 - 335)**. To warranty earlier trip level in any value, auxiliary supply of 230 Vac. must be applied or pins **(1-2)** must be connected in parallel with the auxiliary supply **(16-18)**.

3.2.- Tripping curve selection. (Figure 7)

There are five tripping curves available.

Curve n°1, (C1) - Protection transformers standard characteristic. (Figure 1)

Curve n°2, (C2) - Wire protection. (Figure 2)

Curve n°3, (C3) - "S1" Protection characteristic for Sweden transformers with increase of overload capability. (Figure 3)

Curve n°4, (C4) - "S2" Protection characteristic for Sweden transformers with increase of overload capability. (Figure 4)

Curve n°5, (C5) - Characteristic "FULL RANGE" protection transformers for Denmark. (Figure 5)

Selection of any of these curves depends on the kind of work for which the relay has been configured depending on the protection level. Such selection will be done by **CURVE** settings in front of the equipment.

According to n value and the kind of curve, the calculation of tripping value will be done either with RMS value or pick value.

Such values are those indicated in the table.

Curve, n°	RMS / VPick (n)
1	7
2	7
3	4
4	5
5	6

3.3.- Current setting (I_N). (Figure 7).

Front selectors, (I_N) can adjust overcurrent setting point for timing starting. The number of settings is four in the relay and two in the measurement toroid, a total of eight current setting are available. Setting can be done according next table:

Selection I_N	CT1 S0 - S1	CT1 S0 - S2
In a	14.4A	41A
In b	18.7A	53.4A
In c	24.3A	69.5A
In d	31.6A	90.3A

Selection I_N	CT2 S0 - S1	CT2 S0 - S2
In a	117.4A	335A
In b	152.7A	436A
In c	198.5A	566A
In d	258A	737A

3.7.- Display indicators. (Figure 7).

Four LED's in front of the equipment are available to allow visualisation of Relay State. Firstly the led, ($I_N >$), which is activated indicating that the relay is in timing state.

Second led (**Trip Ext.**), third led (**Trip I_N**) and fourth led (**Trip $I_o > I_n$**), are lighting only when pushing (**READ FAULT**) button. The led activated will indicate the cause of the last trip.

To reset display indicators both (**RESET**) and (**READ FAULT**) buttons must be pressed simultaneously.

When the system recovers internal supply energy, it resets automatically display register.

3.8.- External trip.

Supplying 230 Vac. we indicate to the μC that it can trips through input external trip connection terminals.

Earlier signal is timed 100ms to avoid unexpected trips.

Such trip is performed while system is in self supply situation and has a primary current greater than 80% the minimum value from the range (**$I_n a$**) witch corresponds, depending on the transformers connections (**14.4 - 41.1 - 117.4 - 335**).

To warranty earlier trip, auxiliary supply of 230 Vac. must be applied or extern trip pins 1-2 must be connected in parallel with the auxiliary supply 16-18. So that when an external trip is necessary, relay supply is done allowing the μC to conduct trip.

3.9.- Test of the measurement system.

Through the test coil of the measurement transformer, terminals (**C-D**), test is performed. To know exactly the current required by the test coil it is necessary to know the current we wish to rehearse. Then we divide the value by 48 (CT1) or 391 (CT2), the value of the coil measurement transformer relationship

The value of the current under test along with the relay adjusted value of ($I_N >$) will allow us to know the value of the current relationship for the calculation of the tripping time over selected curve.

4.- INTERNAL ELECTRONIC SYSTEM

4.1.- Signal acquisition and processing.

The equivalent value of the primary signal comes from secondary current internal measuring transformers. Such signal passes across an analogue to digital converter to be processed by a μC to obtain RMS and pick values. Samples are taken every 1.25 ms (for 50Hz signals) in each of the three phases. The three phase highest value is used to calculate the trip value.

The timing is activated when the current relationship read by the toroid is equal or higher than the adjusted value as threshold value in the relay. I.e ($I_N=18\text{A}$, $I_N>14.4\text{A}$, $n=I_N/I_N>=1.25$).

According to the value of n and the kind of curve, the tripping level calculation is done according the RMS or pick value.

The value obtained by calculation points toward a position of the tripping table where they will be integrated altogether until trip level is obtained. Whether such value is variable the integration will be done by successive trip values. Block diagram. (Figure 8).

When the ground fault function is chosen, the microprocessor will check if the actual ground fault is lower or higher than the set point. If the actual data reaches the set point, the internal timer will be activated. The relay will trip at the end of this time, if ground fault is still over the set point.

4.2.- Trip.

When μC reaches the final of timing it generates a pulse sequence with 50 ms of active time and a recover time which depends of the n value when it trips.

Recover times are next:

Value n ($I_N/I_N>$)	Recover time
1	2 s
2	1 s
3	150 ms
4	50 ms

Pulse sequence is on while either overcurrent or external trip are on.

5.- TECHNICAL DATA

General data.

Solid design.
No maintenance is required.
Free position assembling.
Protection, IP67.
Standard, IEC801-2/3/4, IEC255

Measurement circuit.

Starting current :

In a	In b	In c	In d
0.3A	0.39A	0.51A	0.660A

Power according current: 0.3A = 1.95VA, 0.39A = 2.65VA, 0.51A = 3.75VA, 0.660A = 5.25VA.
Frequency: 50Hz - 60Hz.
Current read error: $\pm 7.5\%$.
Short time current: $I = 100I_N$ for 1 s ; $I_N(0.3A)$

Auxiliary supply.

Voltage: 230Va.c. $\pm 20\%$.
Power: 5.6VA.
Frequency: 50...60Hz.

Exterior trip.

Voltage: 230Va.c. $\pm 20\%$.
Power: 0.25VA.
Frequency: 50...60Hz.

CURVE # 1.
(Figure 1).

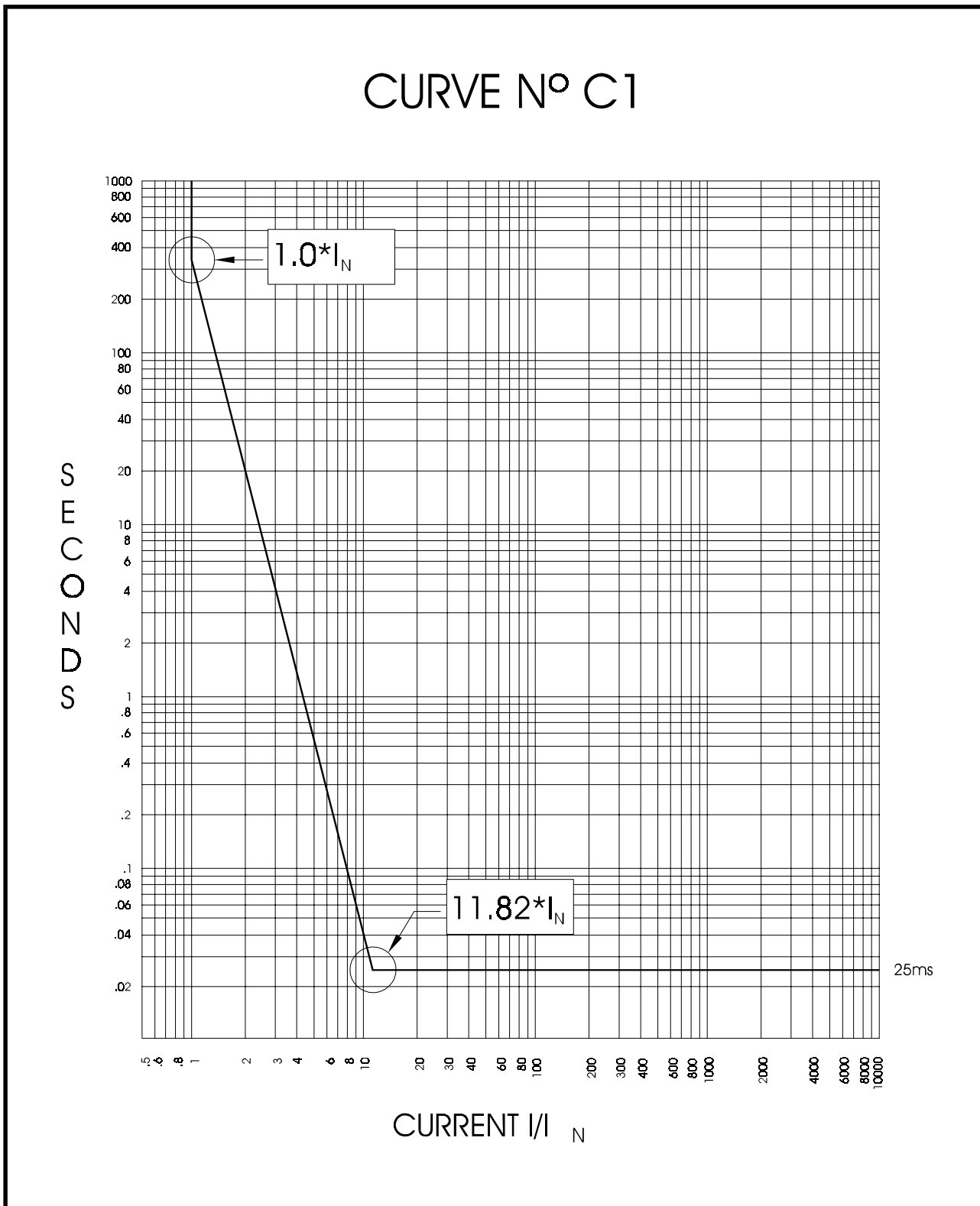

CURVE # 2.
(Figure 2).

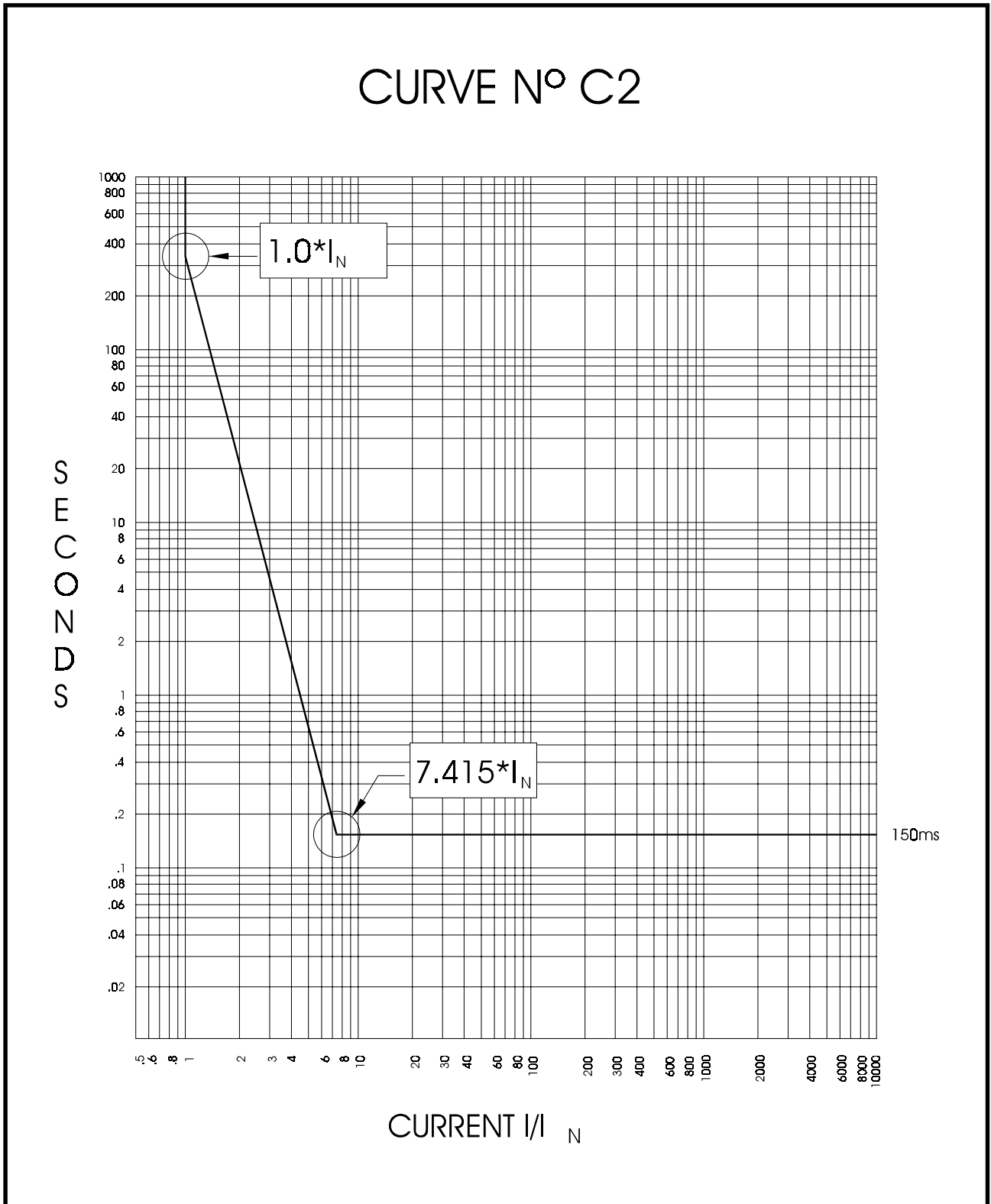

CURVE # 3.
(Figure 3).

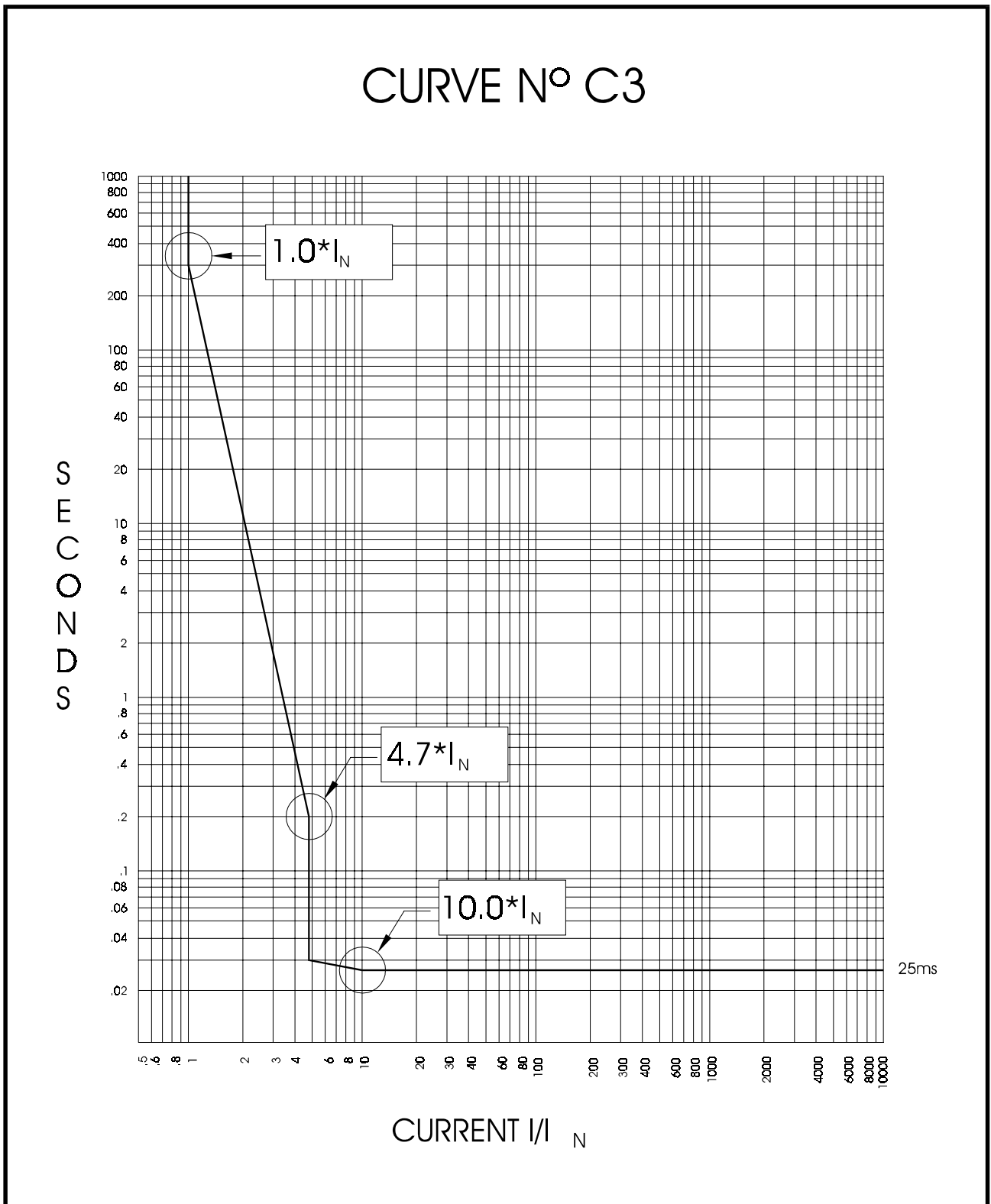

CURVE # 4.
(Figure 4).

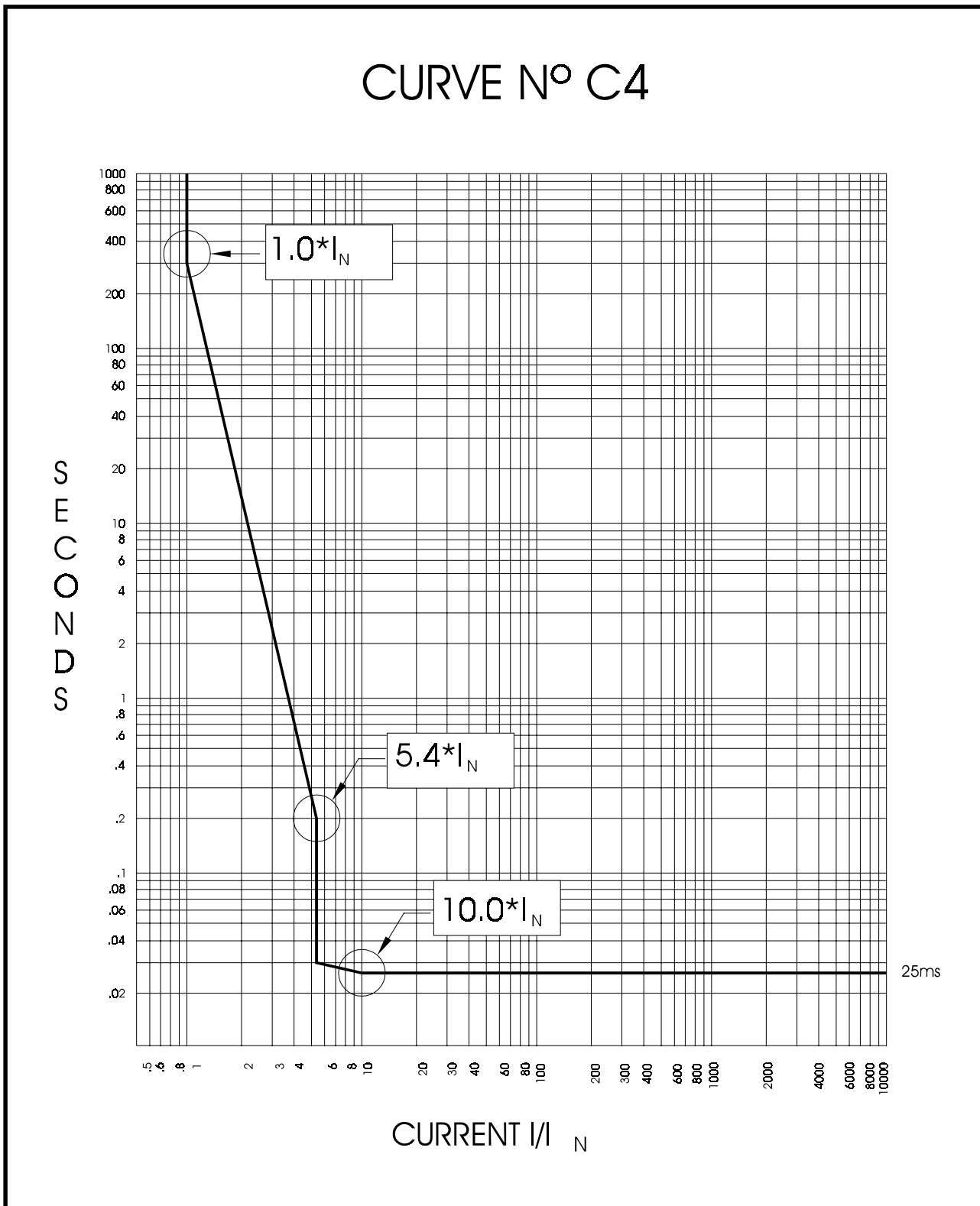

CURVE # 5.
(Figure 5).

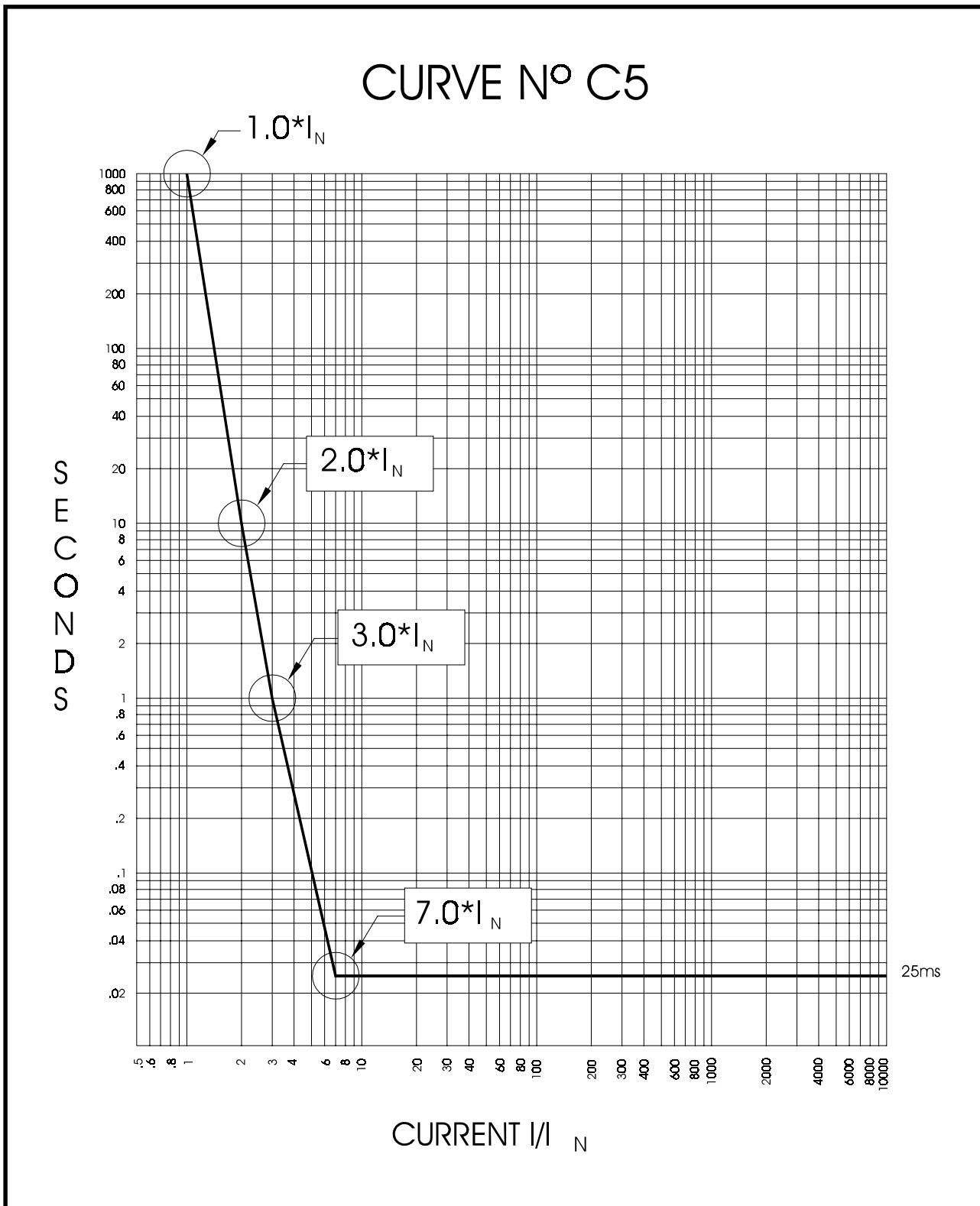

WIRING AND TECHNICAL INSTRUCTIONS STICKER.
(Figure 6).

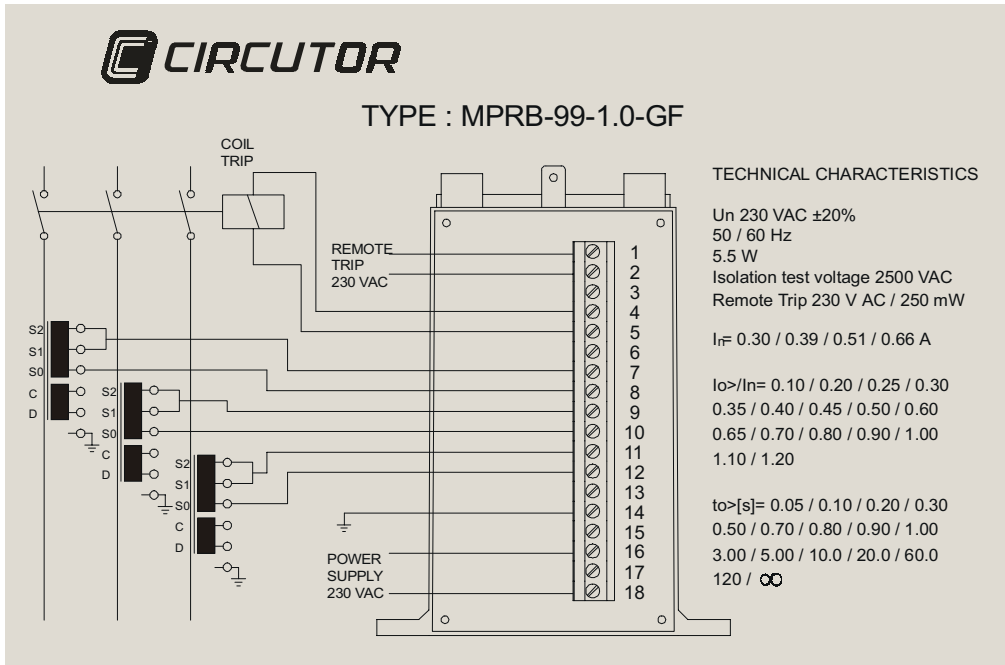

FRONT SIDE.
(Figure 7).

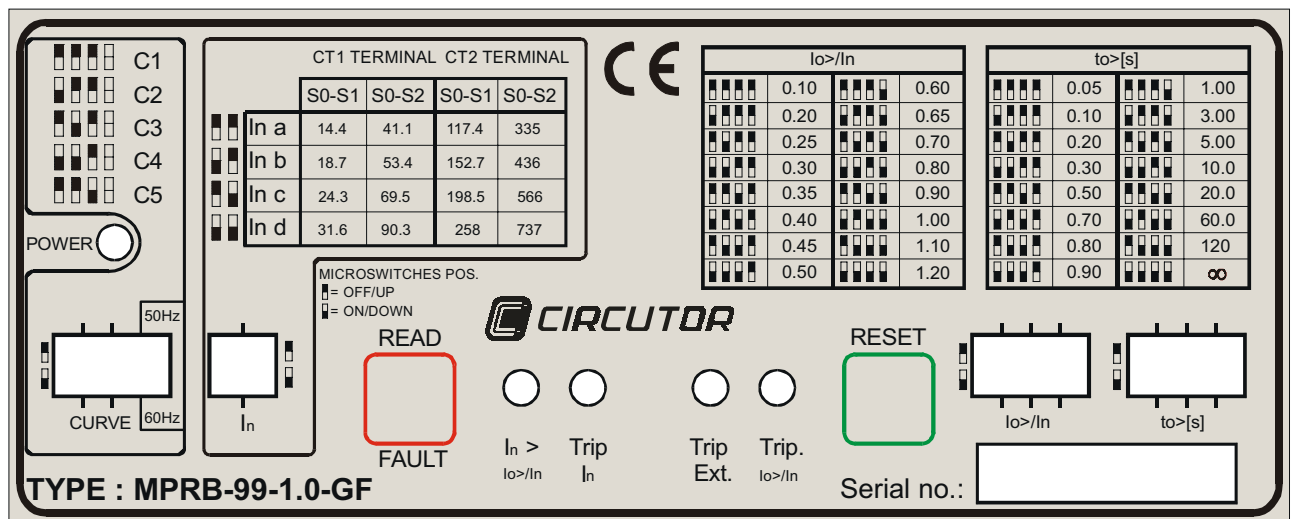

BLOCK DIAGRAMME.
(Figure 8).

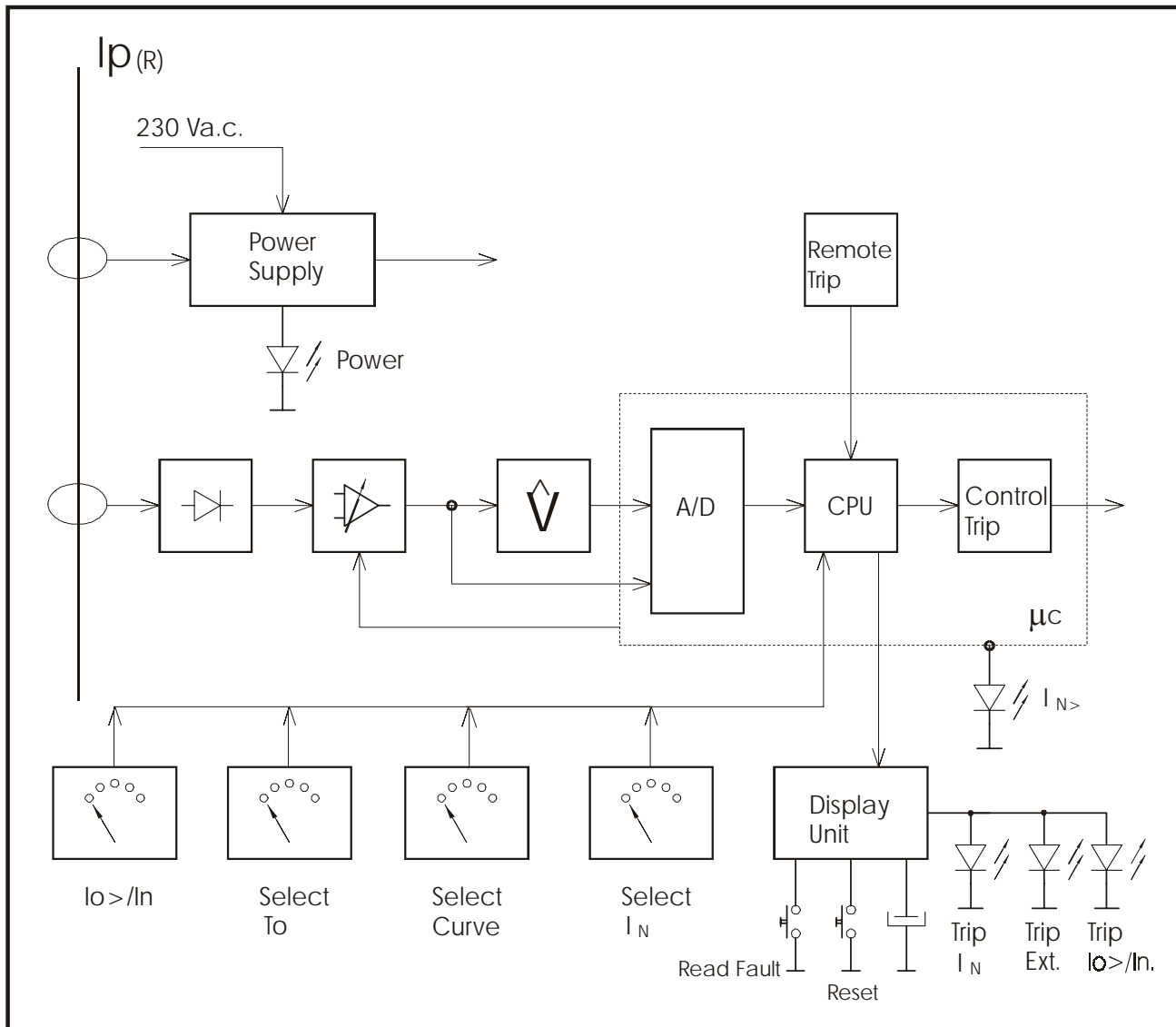

**DIMENSIONS OF RELAY MPRB 2000
(Figure 9).**

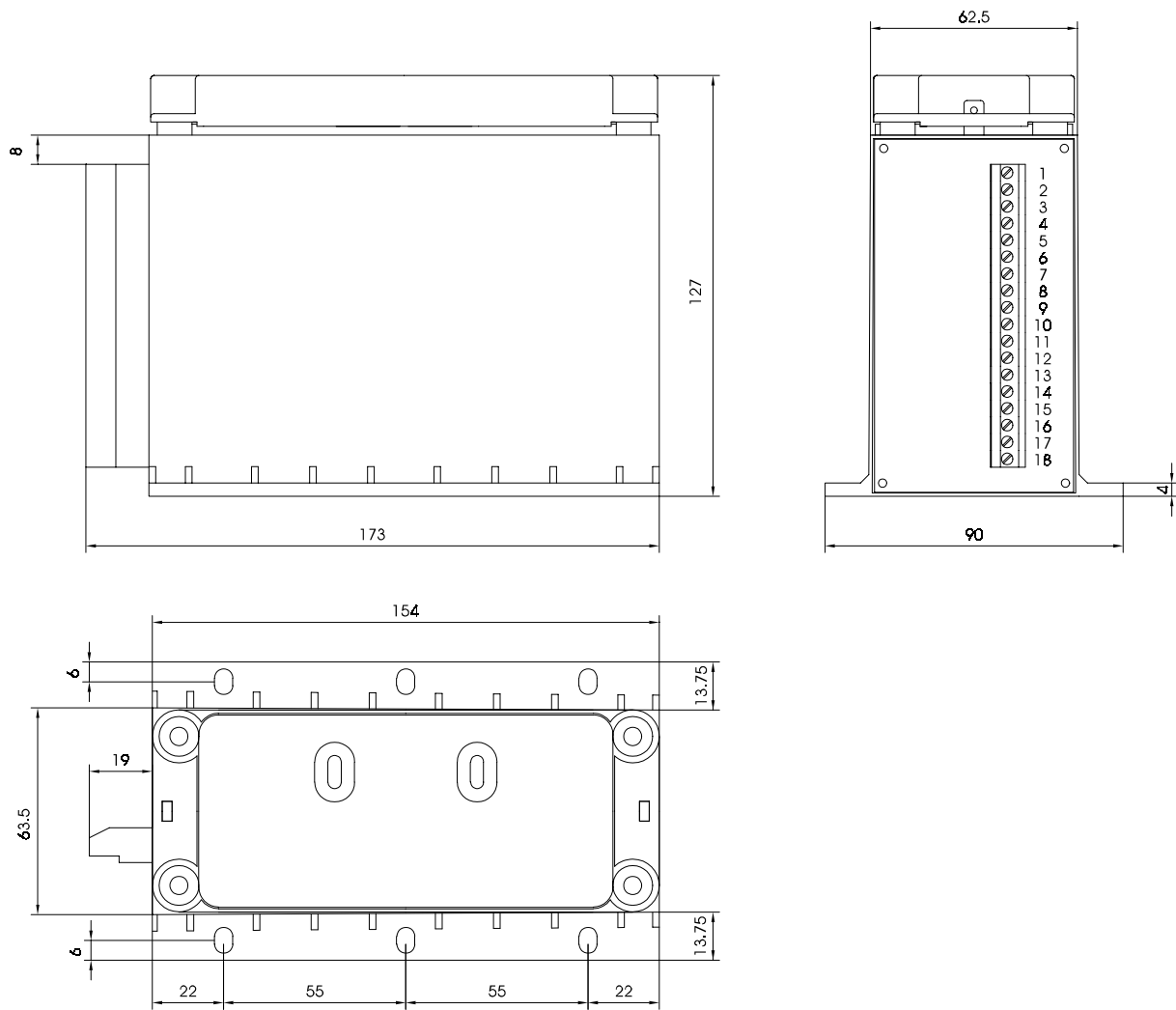

**DIMENSIONS AND WIRING OF TRANSFORMER MPTA 96-14-90.
(Figure 10).**

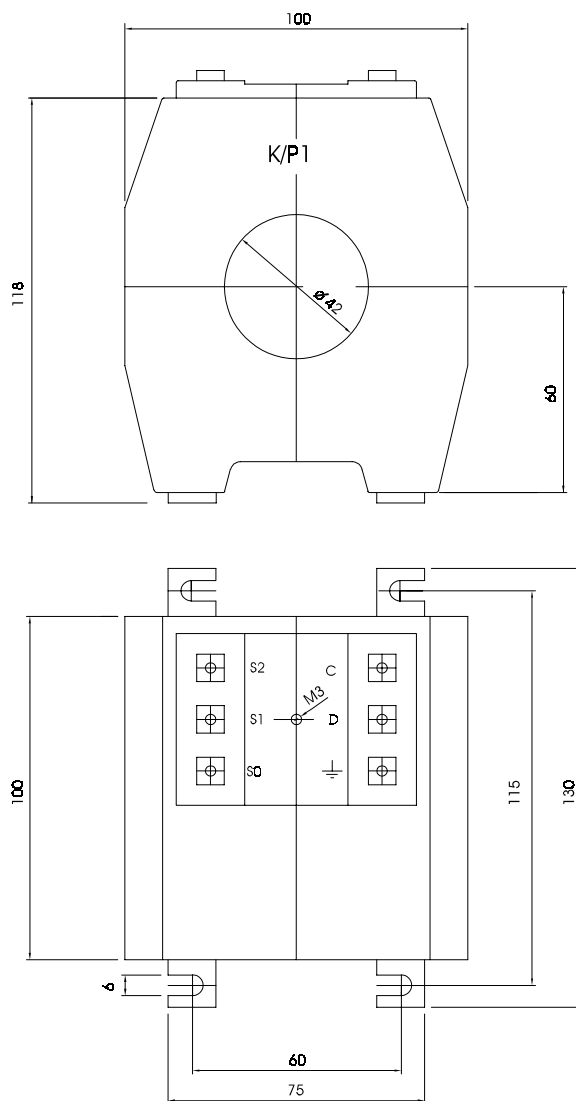

CT1 TERMINAL			
	CURRENT SET		TEST
In	S0 - S1	S0 - S2	C - D
In a	14,4 A	41,1 A	
In b	18,7 A	53,4 A	
In c	24,3 A	69,5 A	
In d	31,6 A	90,3 A	

**DIMENSIONS AND WIRING OF TRANSFORMER MPTA 96-117-737.
(Figure 11).**

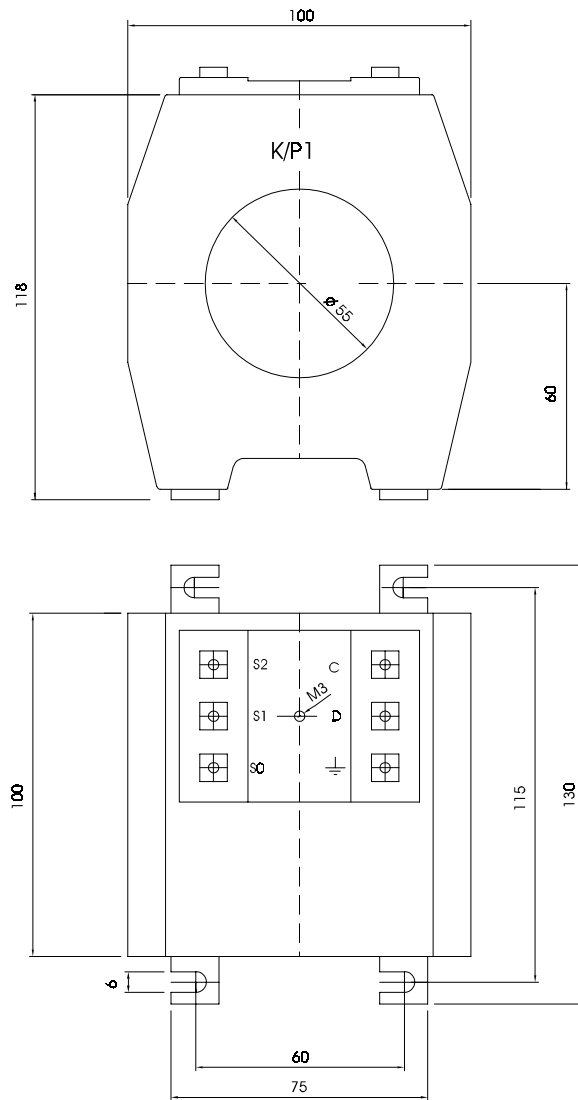

CT2 TERMINAL			
CURRENT SET			TEST
In	S0 - S1	S0 - S2	C - D
In a	117,4 A	335 A	
In b	152,7 A	436 A	
In c	198,5 A	566 A	
In d	258 A	737 A	